

THIS DRAWING IS UNPUBLISHED. RELEASED FOR PUBLICATION 20  
 © COPYRIGHT 20 BY TYCO ELECTRONICS CORPORATION. ALL RIGHTS RESERVED.

LOC	DIST	REVISIONS					
		P	LTR	DESCRIPTION	DATE	DWN	APVD
B	E		L	ECR-07-014340	15/06/07	MJG	JA

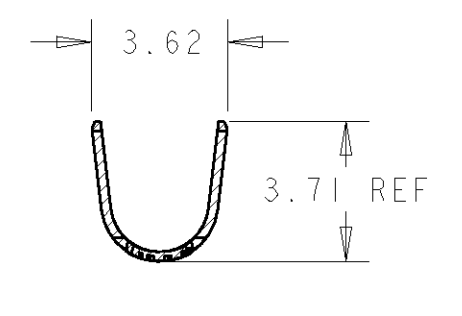
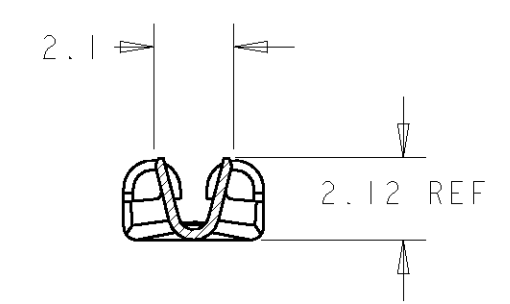
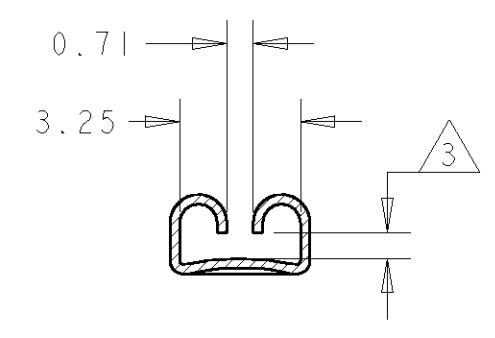
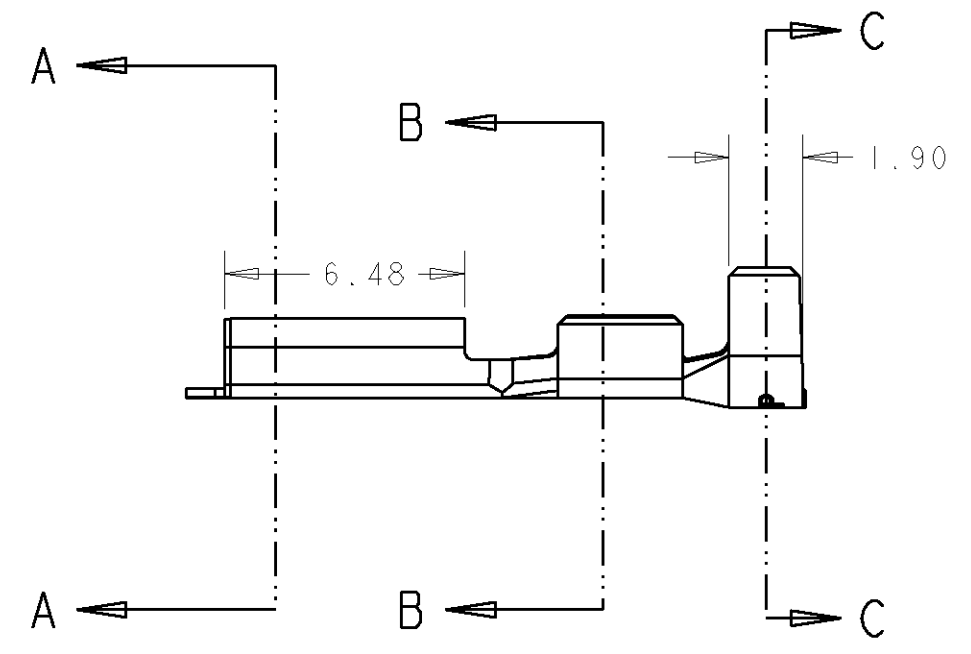
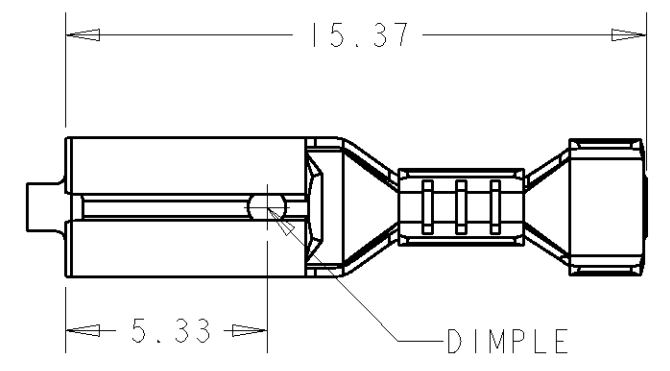

SECTION A-A

SECTION B-B

SECTION C-C

NOTES:

- 1. WIRE SIZE: 0.2 - 0.56mm<sup>2</sup>
- 2. INSULATION DIAMETER: 2.0 - 3.0mm
- 3 TO SUIT 0.50mm THICK TAB

	NONE	NICKEL SILVER	150500-8
SPLICE FREE	ELECTRO TIN	BRASS	150500-7
	NONE	PHOS BRONZE	150500-6
	SILVER PLATED	BRASS	150500-5
	PRE-TIN	BRASS	150500-4
	GOLD PLATED	BRASS	150500-3
	ELECTRO TIN	BRASS	150500-2
	NONE	BRASS	150500-1
REELING	FINISH	MATERIAL	PART NO

<small>THIS DRAWING IS A CONTROLLED DOCUMENT FOR TYCO ELECTRONICS CORPORATION          IT IS SUBJECT TO CHANGE AND THE CONTROLLING ENGINEERING ORGANIZATION          SHOULD BE CONTACTED FOR THE LATEST REVISION.</small>		DWN M.GREENER 15JUN2007 CHK J.AMBROSE 15JUN2007 APVD J.AMBROSE 15JUN2007	Tyco Electronics UK Ltd. Bideford, North Devon, EX39 4HE
DIMENSIONS: mm 	TOLERANCES UNLESS OTHERWISE SPECIFIED: 0 PLC ±0.5 1 PLC ±0.5 2 PLC ±0.5 3 PLC ±0.5 4 PLC ± ANGLES ±2 FINISH -	PRODUCT SPEC 108-20020 APPLICATION SPEC 114-2036 WEIGHT -	NAME .110 SERIES MINIATURE FASTON RECEPTACLE SIZE A3 CAGE CODE 00779 C=150500 DRAWING NO 150500 RESTRICTED TO
MATERIAL SEE TABLE	CUSTOMER DRAWING		SCALE NTS SHEET 1 OF 1 REV L