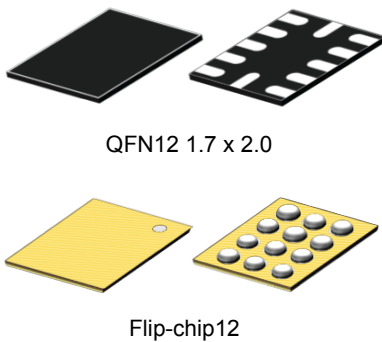


## Ultra-low current consumption linear battery charger



### Features

- Charges thin film battery with CC-CV algorithm
- L version suitable for Li-Ion batteries
- Charging current up to 40 mA (selectable by dedicated pins)
- 250 nA battery leakage current
- Reverse current protection from battery to supply input
- Programmable floating voltage with 0.5% accuracy
- Battery overcurrent protection
- Battery over-discharge protection switch totally disconnects battery for cell durability
- Shelf-mode supported, no battery mechanical switch needed
- Power-Good open-drain output
- Valid source open drain output
- Peak mode input to avoid over-discharge false triggering
- Available packages:
  - QFN12 1.7 x 2.0 mm, thickness 0.55 mm max.
  - Flip-chip12 1.1 x 1.4 mm, 300  $\mu$ m pitch

### Applications

- Fitness portable Internet of Things
- Energy harvesting application
- Smart cards
- Wireless sensor nodes
- Portable health care devices
- Fitness and wellness wearable devices

Maturity status link

[STBC15](#)

### Description

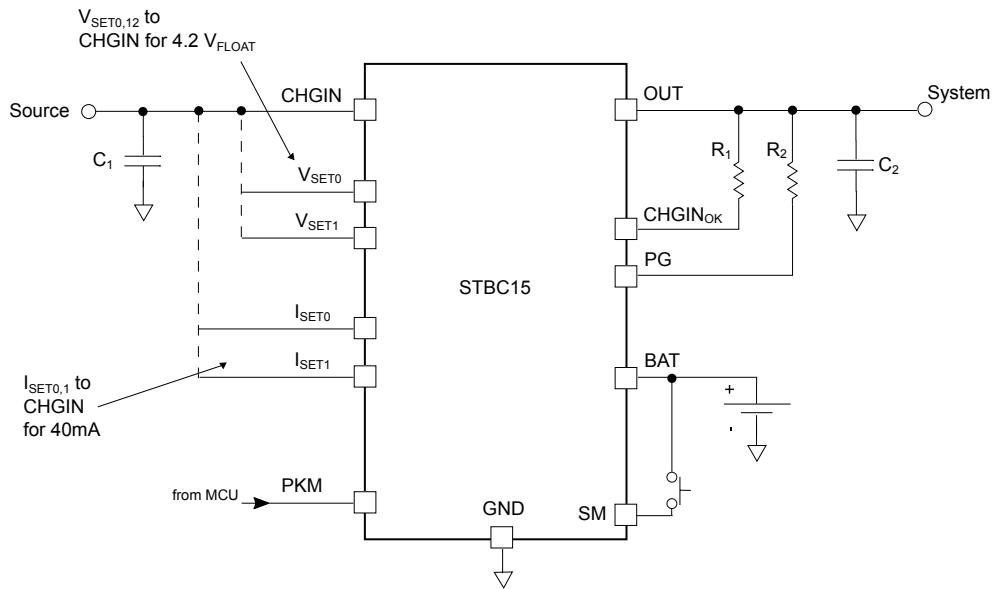
The **STBC15** is a linear charger thin film battery with a maximum charging current of 40 mA. The device uses a CC/CV algorithm to charge the battery. Thanks to the ultra-low consumption architecture, the charger is suitable for low-capacity cells such as thin film batteries and can use low energy sources such as energy harvesters. A 5 V input like a standard USB port can be used as a voltage source as well. A specific version (-L) is available to charge Li-Ion cells.

The **STBC15** integrates an over-discharge and overcurrent protection circuitry to prevent the battery from being damaged under fault conditions. The floating voltage value can be set to four different values by using dedicated selection inputs. A higher set of floating voltages, suitable for Li-Ion batteries, is available in the -L version of the product. A dedicated pin allows the device to be set in shelf-mode. In this condition, the **STBC15** consumes less than 10 nA, thus not discharging the battery before the final device is activated by the end user. The ultra-low power architecture allows the **STBC15** to consume less than 250 nA when the input power source is removed and less than 10 nA in over-discharge-mode.

The device is available in a (1.7 × 2.0 mm) 12-lead QFN package, 400  $\mu$ m pitch, 0.55 mm max. thickness or in Flip-chip 1.1 x 1.4 mm 12 bumps 300  $\mu$ m pitch.

# 1 Application schematic

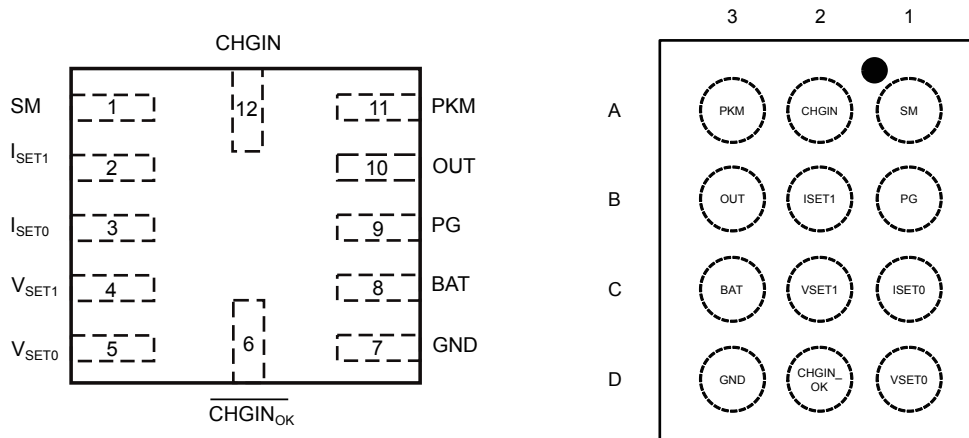
**Figure 1. STBC15 application schematic**



**Table 1. Typical bill of material (BOM)**

Symbol	Value	Description	Note
C1	10 $\mu$ F (16 V)	Input supply voltage capacitor	Ceramic type
C2	10 $\mu$ F (10 V)	System output capacitor	Ceramic type
R1, R2	10 k $\Omega$	Pull-up resistors	Film type

## 2 Pin configuration

**Figure 2. Pin connection (top through view)**

**Table 2. Pin description**

Bump	QFN12	Flip-chip12	Description	
Power	CHGIN	12	A2	Input supply voltage. Bypass this pin to ground with a 10 $\mu$ F capacitor
	BAT	8	C3	Battery positive terminal. Bypass this pin to GND with a 4.7 $\mu$ F ceramic capacitor
	OUT	10	B3	System output. Bypass this pin to ground with 1 $\mu$ F ceramic capacitor
	GND	7	D3	Ground
Programming	VSET0	5	D1	VFLOAT selection input pins. Connect the pin to CHGIN or GND (no internal pull-up/down resistors). Pin must be tied to GND or CHGIN
	VSET1	4	C2	
	ISET0	3	C1	Charging current selection input pins. Pins must be tied to GND or CHGIN
	ISET1	2	B2	
Digital I/Os	PKM	11	A3	Peak mode input
	PG	9	B1	Power-Good signal, active high-z open-drain output
	$\overline{\text{CHGIN}}_{\text{OK}}$	6	D2	Charging source status. It is an active high-z open drain output
	SM	1	A1	Shelf mode activation pin. Active high input with internal pull-down resistor. When high, the device enters shelf-mode

### 3 Maximum ratings

**Table 3. Absolute maximum ratings**

Symbol	Parameter	Test conditions	Value	Unit
CHGIN	Input supply voltage pin	DC voltage	-0.3 to +7.0	V
BAT	Battery pin and system OUT pin	DC voltage	-0.3 to +5.5	V
		Non repetitive, 60 s pulse length	-0.3 to +6.0	V
OUT	Battery pin and system OUT pin	DC voltage	-0.3 to +6.0	V
CHGIN <sub>OK</sub> , V <sub>SET0,1</sub> , I <sub>SET0,1</sub> , PG, SM, PKM	I/O pins	DC voltage	-0.3 to +7.0	V
ESD	Charged device model (CDM)		±500	V
	Human body model (all the others)		±2000	V
T <sub>AMB</sub>	Operating ambient temperature		-40 to +85	°C
T <sub>J</sub>	Maximum junction temperature		+125	°C
T <sub>STG</sub>	Storage temperature		-65 to +150	°C

*Note:* Absolute maximum ratings are those values beyond which damage to the device may occur. Functional operation under these conditions is not implied.

**Table 4. Thermal data**

Symbol	Parameter	QFN12	Flip-chip12	Unit
R <sub>THJB</sub> <sup>(1)</sup>	Junction-to-pcb board thermal resistance	100	160	°C/W

1. Standard FR4 pcb board.

## 4 Electrical characteristics

$V_{CHGIN} = 5\text{ V}$ ,  $V_{BAT} = 3.6\text{ V}$ ,  $C_1 = 10\text{ }\mu\text{F}$ ,  $C_2 = 10\text{ }\mu\text{F}$ ,  $V_{SET0,1} = 0\text{ V}$ ;  $I_{SET0,1} = 0\text{ V}$ , SM floating,  $T_A = 25\text{ }^\circ\text{C}$ , unless otherwise specified.

**Table 5. Electrical characteristics**

Symbol	Parameter	Test conditions	Min.	Typ.	Max.	Unit
CHGIN	Operating input voltage	$V_{float}$ set 4.2 V, $I_{FAST} < 250\text{ mA}$	$V_{CHGIN\_UVLO}$		6.5 <sup>(1)</sup>	V
$V_{BATMIN}$	Minimum battery voltage		3.2			V
$V_{CHGIN\_UVLO}$	CHGIN undervoltage lockout threshold - rising	$V_{BAT} < V_{BAT\_OVD}$	3.3	3.5		V
$V_{CHGIN\_UVLO\_H}$	CHGIN undervoltage lockout hysteresis	$V_{BAT} < V_{BAT\_OVD}$		150		mV
$I_{CHARGE}$	Battery charging current (CC mode)	$0\text{ V} < V_{BAT} < V_{FLOAT}$ $I_{SET0,1} = CHGIN$	36	40	44	mA
		$0\text{ V} < V_{BAT} < V_{FLOAT}$ $I_{SET1} = CHGIN, I_{SET0} = GND$	26	30	34	mA
		$0\text{ V} < V_{BAT} < V_{FLOAT}$ $I_{SET1} = GND,$ $I_{SET0} = CHGIN$	16	20	24	mA
		$0\text{ V} < V_{BAT} < V_{FLOAT}$ $I_{SET0,1} = GND$	8	10	12	mA
$V_{FLOAT}$	Battery float voltage (CV mode)	STBC15, $I_{BAT} = 10\text{ }\mu\text{A}$ , $V_{SET0,1} = CHGIN, T_A = 25\text{ }^\circ\text{C}$	4.180	4.2	4.221	V
		STBC15L, $I_{BAT} = 10\text{ }\mu\text{A}$ , $V_{SET0,1} = CHGIN, T_A = 25\text{ }^\circ\text{C}$	4.378	4.4	4.422	V
	Battery float voltage (CV mode), temperature variation <sup>(1)</sup>	STBC15, $I_{BAT} = 10\text{ }\mu\text{A}$ , $V_{SET0,1} = CHGIN, T_A = -40\text{ to }85\text{ }^\circ\text{C}$	4.158	4.2	4.242	V
		STBC15L, $I_{BAT} = 10\text{ }\mu\text{A}$ , $V_{SET0,1} = CHGIN, T_A = -40\text{ to }85\text{ }^\circ\text{C}$	4.356	4.4	4.444	V
$I_{CC}$	IC supply current	$T_A = -40\text{ to }85\text{ }^\circ\text{C}$		580	1000	nA
$I_{BAT}$	Leakage on BAT pin	$V_{CHGIN} = 0\text{ V}$ , $V_{BAT} < V_{BAT\_OVD}$		4	10	nA
		$V_{CHGIN} = 0\text{ V}, I_{OUT} = 0\text{ A}$ , $V_{BAT} > V_{BAT\_OVD}$		250	380	nA
		Shelf-mode, $V_{CHGIN} = 0\text{ V}$ , $V_{BAT} = 4\text{ V}$		4	10	nA

Symbol	Parameter	Test conditions	Min.	Typ.	Max.	Unit
V <sub>BAT_OVD</sub>	Battery over discharge disconnection threshold	STBC15, V <sub>CHGIN</sub> = 0 V, I <sub>OUT</sub> = 0 A, PKM = 0 (peak mode disabled)	3.15	3.25	3.3	V
		STBC15, V <sub>CHGIN</sub> = 0 V, I <sub>OUT</sub> = 0 A, PKM=1 (peak mode enabled)	2.15	2.25	2.3	
		STBC15L, V <sub>CHGIN</sub> = 0 V, I <sub>OUT</sub> = 0 A, PKM = 0 or 1	2.60	2.7	2.75	
V <sub>BAT_FF</sub>	Battery disconnected FF retention voltage	V <sub>CHGIN</sub> = 0 V, V <sub>BAT</sub> < V <sub>BAT_OVD</sub>	1.8			V
V <sub>BAT_CONN</sub>	Battery connected threshold – rising	STBC15, V <sub>CHGIN</sub> = 0 V, I <sub>OUT</sub> = 0 A, PKM = 0 or 1	3.98	4.1	4.22	V
		STBC15L, V <sub>CHGIN</sub> = 0 V, I <sub>OUT</sub> = 0 A, PKM = 0 (peak mode disabled)		3.6		V
		STBC15L, V <sub>CHGIN</sub> = 0 V, I <sub>OUT</sub> = 0 A, PKM=1 (peak mode enabled)		3.9		V
V <sub>BAT_CONN_H</sub>	Battery connected threshold hysteresis		100			mV
V <sub>BAT_ASD</sub>	Battery ASD threshold	V <sub>CHGIN</sub> -V <sub>BAT</sub>		50		mV
V <sub>BAT_RECHG</sub>	Battery recharge threshold	V <sub>BAT</sub> -V <sub>CHGIN</sub>		170		mV
R <sub>IN_BAT</sub>	Input-to-battery on-resistance			6	10	Ω
R <sub>DSON_M3</sub>	M3 transistor on-resistance			3		Ω
R <sub>IN_SM</sub>	Input shelf mode pull-down resistor	SM pin vs. GND		100		kΩ
I <sub>IN_PKM</sub>	PKM input current leakage				0.1	nA
I <sub>IN_SET</sub>	V <sub>SET0,1</sub> , I <sub>SET0,1</sub> input current leakage				0.1	nA
V <sub>IL</sub>	Logic low input level (V <sub>SET0,1</sub> , I <sub>SET0,1</sub> )	To see threshold plot in full temperature range			0.4	V
V <sub>IH</sub>	Logic high input level (V <sub>SET0,1</sub> , I <sub>SET0,1</sub> )		1.6		V <sub>CHGIN</sub>	V
V <sub>IL2</sub>	Logic low input level (SM, PKM)				0.4	V
V <sub>IH2</sub>	Logic high input level (SM, PKM)	V <sub>BAT</sub> = 3.6 V	1.8		V <sub>OUT</sub>	V
		V <sub>BAT</sub> = 4.2 V	2.0		V <sub>OUT</sub>	
V <sub>OLPG</sub>	PG output logic level	I <sub>OL</sub> = 1 mA			0.4	V
I <sub>OHPG</sub>	PG output current leakage	V <sub>OH</sub> = 3.3 V		0.2		μA
V <sub>OL-CHGIN_OK</sub>	$\overline{\text{CHGIN}}_{\text{OK}}$ , output logic level	I <sub>OL</sub> = 1 mA			0.4	V

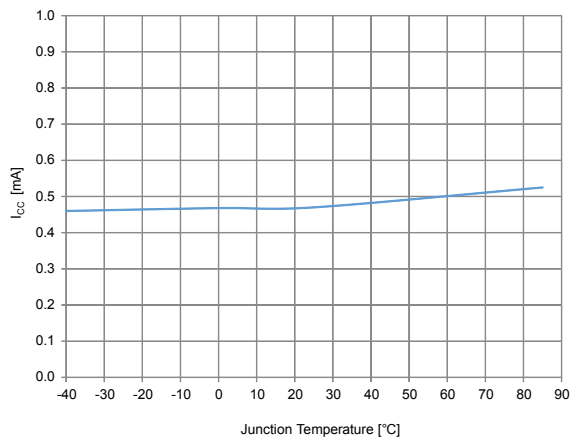
Symbol	Parameter	Test conditions	Min.	Typ.	Max.	Unit
$I_{OH-CHGIN\_OK}$	$\overline{CHGIN}_{OK}$ . output current leakage	$V_{OH} = 3.3\text{ V}$		0.2		$\mu\text{A}$

1. Exceed maximum operative condition could damage internal device and reduce overall reliability level. In case external source could exceed this value, even during limited timing period, it is recommended to add external voltage clamp.

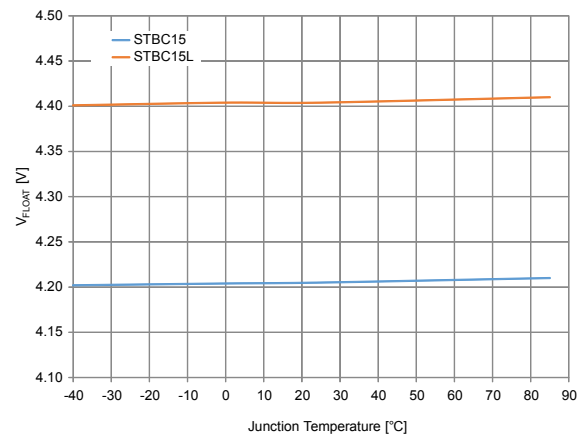
## 5 Typical performance characteristics

$V_{CHGIN} = 5\text{ V}$ ,  $V_{BAT} = 3.6\text{ V}$ ,  $C_1 = 10\ \mu\text{F}$ ,  $C_2 = 10\ \mu\text{F}$ ,  $V_{SET0,1} = 0\text{ V}$ ;  $I_{SET0,1} = 0\text{ V}$ , SM floating,  $T_A = 25\text{ }^\circ\text{C}$ , unless otherwise specified.

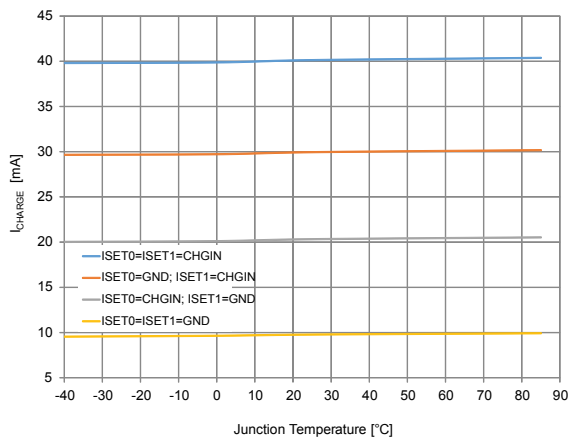
**Figure 3.  $I_{CC}$  vs. temperature ( $V_{BAT} = 3.6\text{ V}$ ;  $I_{OUT} = 1\text{ mA}$ )**



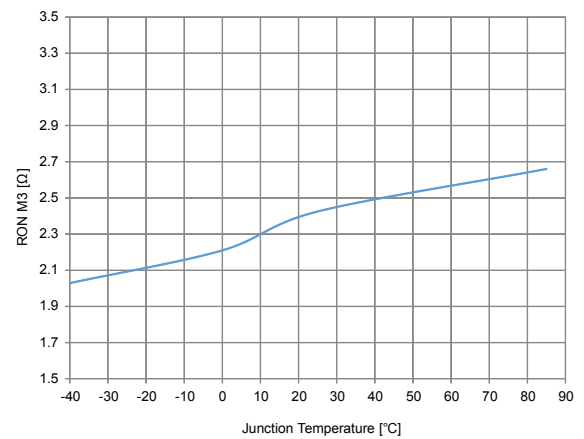
**Figure 4. Floating voltage vs. temperature**



**Figure 5. Charge current vs. temperature**

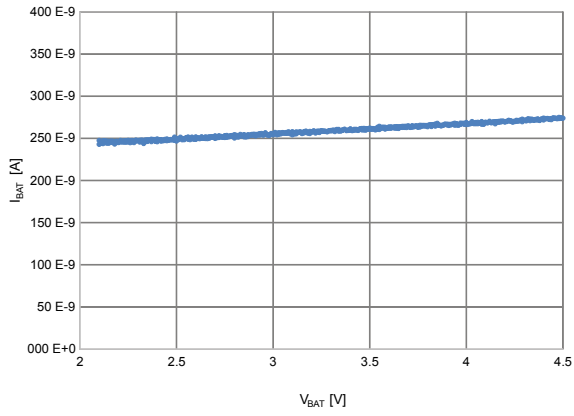


**Figure 6.  $R_{ON\ M3}$  vs. temperature**

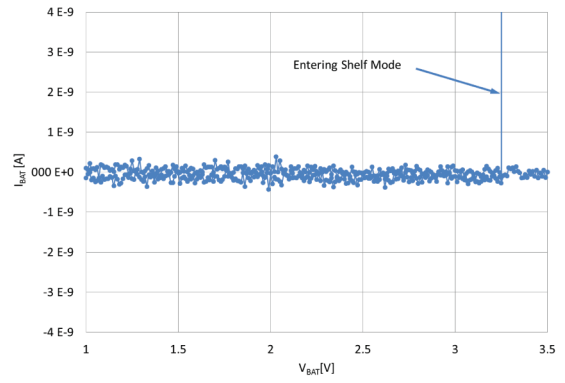




**Figure 7. Battery leakage current vs.  $V_{BAT}$  ( $V_{CHGIN} = 0\text{ V}$ ;  $V_{BAT} > V_{BAT\_OVD}$ )**



**Figure 8. Battery leakage current vs.  $V_{BAT}$  ( $V_{CHGIN} = 0\text{ V}$ ;  $V_{BAT} < V_{BAT\_OVD}$ ; shelf mode)**



## 6 Control pin description

### PG

Power-Good open-drain, active high-z output pin. It provides the status about OUT valid voltage based. If OUT voltage is higher than  $V_{BAT\_CONN}$  (4.1 V) then the pin goes to high-z. It is pulled down if OUT voltage is lower  $V_{BAT\_CONN}$  (4.1 V). It requires an external pull-up resistor connected to VOUT.

### CHGIN<sub>OK</sub>

Input voltage source Power Good pin. It goes to high-z when the input voltage source is not valid. Logic negate.

### V<sub>SET0,1</sub>

Set the floating battery voltage value. They can be tied to CHGIN or GND thus determining four different settings.

### I<sub>SET0,1</sub>

Set the charging current. They can be tied to CHGIN or GND thus determining four different settings.

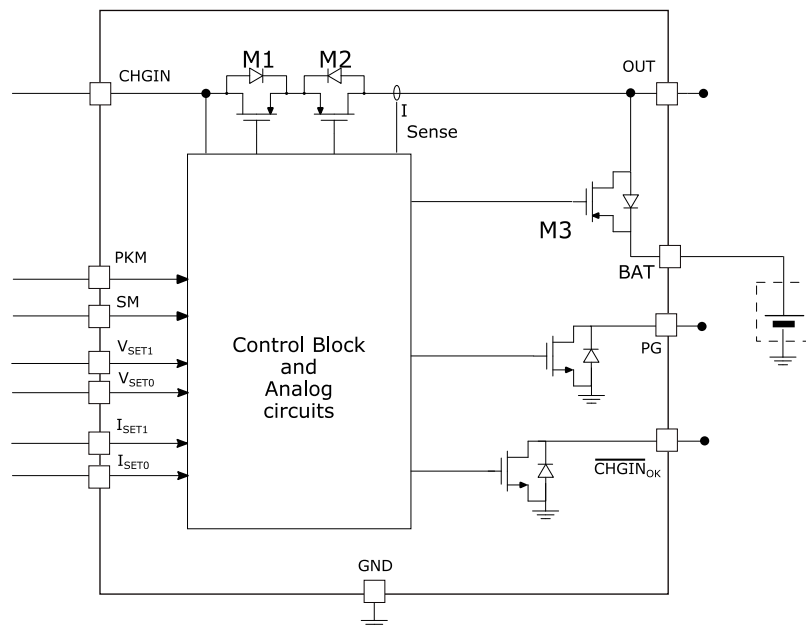
### PKM

Peak mode input. It allows reducing battery shutdown threshold from normal operating mode to lower threshold level. This enables the application to temporarily support load peak current that could otherwise generate false battery shutdown detection.

### SM

Shelf-mode activation pin. Active high input with internal pull-down resistor to reduce external components. When high, the device enters shelf-mode. Block diagram.

**Figure 9. STBC15 block diagram**



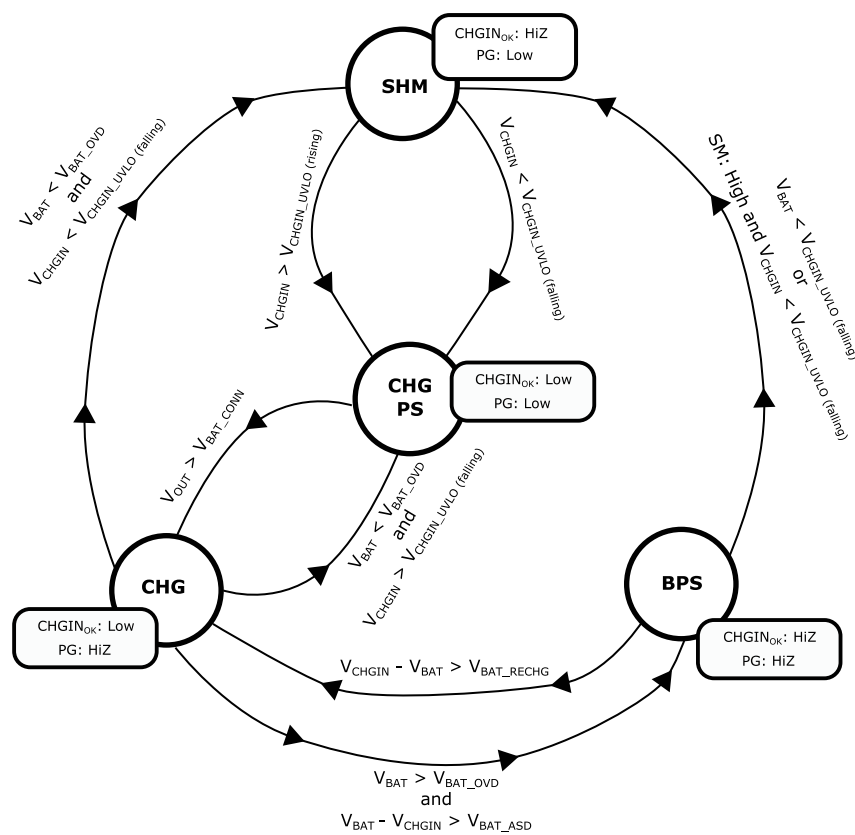
## 7 Operation description

### 7.1 Battery charger finite state machine (FSM)

The battery charger implements a CC/CV control algorithm to charge the battery connected to BAT. Since the STBC15 is dedicated to low capacity batteries pre-charge or termination phases are not necessary. Both the floating voltage and the charging current are configurable by dedicated pins,  $V_{SET1,2}$  and  $I_{SET1,2}$ .

The device finite state machine behavior is shown in following diagram.

Figure 10. Operational simplified state machine diagram



SHM: shelf mode

BPS: system powered by battery

CHG: battery is being recharged,  $V_{out}$  ok

CHG PS:  $V_{out}$  not good, battery charged through M3 body

### 7.2 Floating voltage selection

The battery floating voltage can be set by  $V_{SET0,1}$  pins. In order to increase the number of charging cycles, lower floating voltage values are preferred. On the other side, the reduced floating voltage leads to the decreased energy stored into the battery.

The battery floating voltage can be set by  $V_{SET0,1}$  pins. In order to increase the number of charging cycles, lower floating voltage values are preferred. On the other side, the reduced floating voltage leads to the decreased energy stored into the battery. The best trade-off can be chosen according to application needs. Different range of floating voltages can be utilized by using different part numbers.

**Table 6. STBC15 floating voltage selection**

VSET1	VSET0	Floating voltage [V]
0	0	4.00
0	1	4.05
1	0	4.10
1	1	4.20

**Table 7. STBC15L floating voltage selection**

VSET1	VSET0	Floating voltage [V]
0	0	4.20
0	1	4.25
1	0	4.35
1	1	4.40

### 7.3 Charge current selection

The charge current is defined by external pin configuration shown in the table below.

**Table 8. Charge current selection**

ISET1	ISET0	Battery charging current [mA]
0	0	10
0	1	20
1	0	30
1	1	40

### 7.4 Battery recharge

When CHGIN voltage drops below the level defined by  $V_{BAT} - V_{BAT\_ASD}$ , the device turns M3 on and the OUT pin is supplied by the battery (BPS state). The battery recharge restarts again when the voltage on CHGIN exceeds the level defined by  $V_{BAT} + V_{BAT\_RECHG}$  voltage. The device goes to *CHG* state.

### 7.5 Over-discharge protection and peak mode

The STBC15 protects the battery by disconnecting it when its voltage is below a certain level defined by the  $V_{BAT\_OVD}$  threshold. This function protects the battery from over-discharging. In order to maintain the over-discharge status, the battery voltage should, in any condition, stay above the  $V_{BAT\_FF}$  threshold.

In some application conditions, such as during RF transmission bursts, it is requested that the battery sustains short transients below the typical  $V_{BAT\_OVD}$  level. In order to support this behavior and avoid false triggering of the over-discharge mechanism, it is possible to lower the  $V_{BAT\_OVD}$  threshold by using the PKM pin. When this pin is pulled low, the  $V_{BAT\_OVD}$  threshold is decreased to a lower level according to the table below.

**Table 9. Battery over-discharge voltages for the STBC15**

PKM	Min. $V_{BAT\_OVD}$ [V]	Max. $V_{BAT\_OVD}$ [V]
0	3.2	3.3

PKM	Min. VBAT_OVD [V]	Max. VBAT_OVD [V]
1	2.2	2.3

**Table 10. Battery over-discharge voltages for the STBC15L**

PKM	Min. VBAT_OVD [V]	Max. VBAT_OVD [V]
x	2.65	2.75

## 7.6 Shelf mode

The STBC15 provides an ultra-low power mode with current consumption less than 10 nA in order to support long period of shelf storage of the final equipment with minimum battery discharge.

In this case, even if the battery is charged and its voltage is above the cut-off voltage, it can be disconnected from the system by applying a positive pulse to SM pin.

## 7.7 Reverse current protection

The STBC15 avoids reverse current flowing from the battery to the input voltage source when the CHGIN voltage is lower than BAT voltage. This is particularly important when a photovoltaic panel is used as an input voltage source. This function is accomplished by turning off M1 switch when CHGIN voltage drops below CHGIN UVLO threshold.

## 7.8 STBC15 / STBC15L difference summary

The STBC15 is dedicated to thin film batteries while the STBC15L to li-Ion batteries. Here below a summary of the main differences:

**Table 11. STBC15 / STBC15L difference summary**

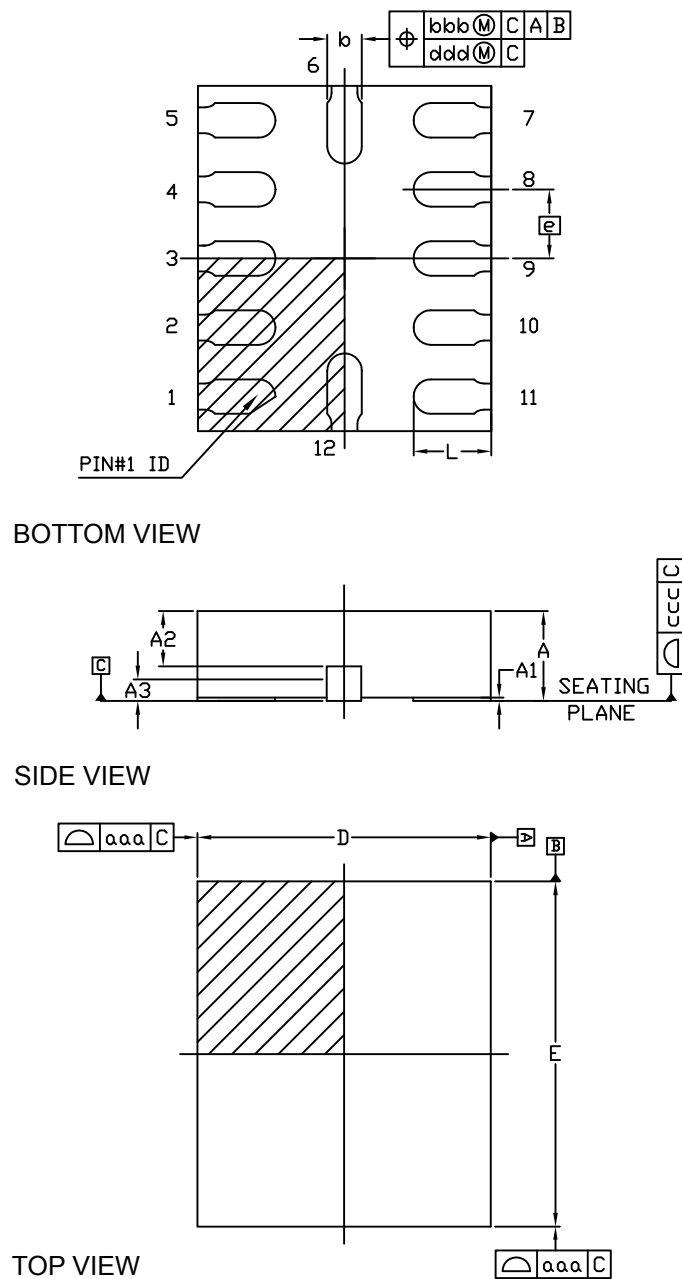
Name	PKM	STBC15	STBC15L
V <sub>FLOAT</sub>	x	4.0 V to 4.2 V	4.2 V to 4.4 V
V <sub>BAT_OVD</sub>	PKM=0	3.25 V	2.7 V
	PKM=1	2.25 V	2.7 V
V <sub>BAT_CONN</sub>	PKM=0	4.10 V	3.6 V
	PKM=1	4.10 V	3.9 V

## 8 Package information

In order to meet environmental requirements, ST offers these devices in different grades of ECOPACK® packages, depending on their level of environmental compliance. ECOPACK® specifications, grade definitions and product status are available at: [www.st.com](http://www.st.com). ECOPACK® is an ST trademark.

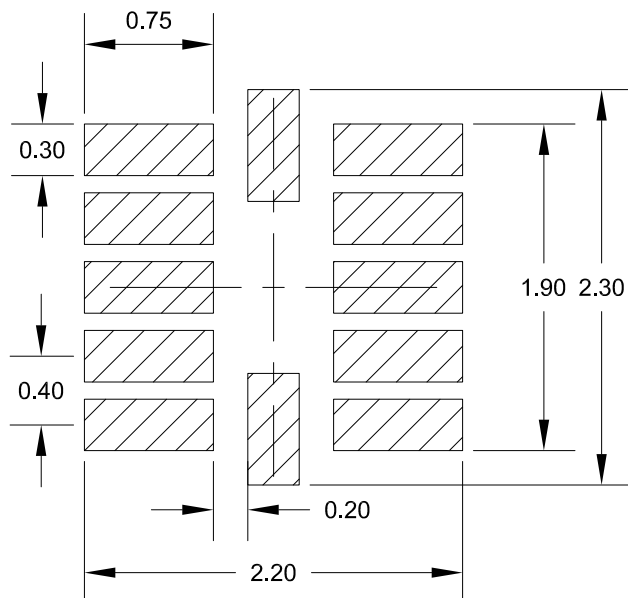
### 8.1 TQFN 12 (2.00 x 1.70 mm) package information

Figure 11. QFN12 (1.7 x 2.0 mm) package outline



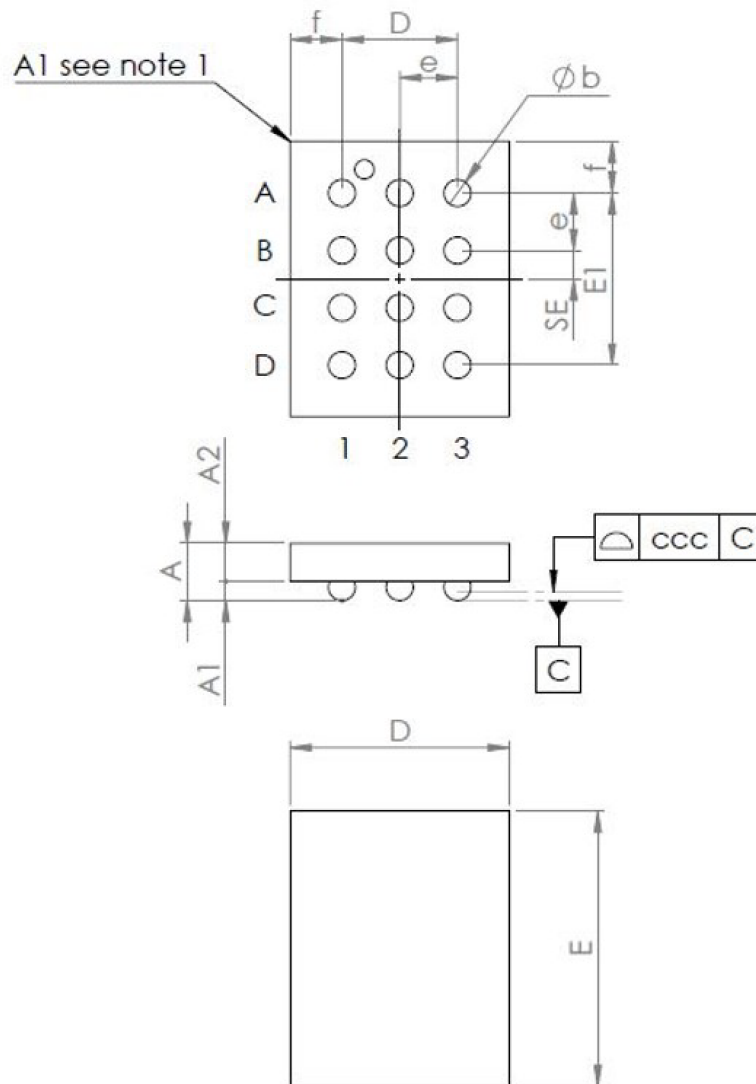
**Table 12. QFN12 (1.7 x 2.0 mm) package mechanical data**

Dim.	mm		
	Min.	Typ.	Max.
A	0.4	0.50	0.55
A1	0.00	0.03	0.05
A2	0.28	0.38	0.48
A3		0.125	
b	0.15	0.20	0.25
D	1.60	1.70	1.80
E	1.95	2.00	2.05
e		0.40	
E	1.90	2.00	2.10
L	0.35	0.45	0.55
aaa		0.15	
bbb		0.10	
ccc		0.08	
ddd		0.05	
eee		0.10	

**Figure 12. QFN12 (1.7 x 2.0 mm) recommended footprint**


## 8.2 Flip-chip12 (1.10 x 1.41 mm) package information

Figure 13. Flip-chip12 (1.1 x 1.41 mm) package outline



**Note 1:**

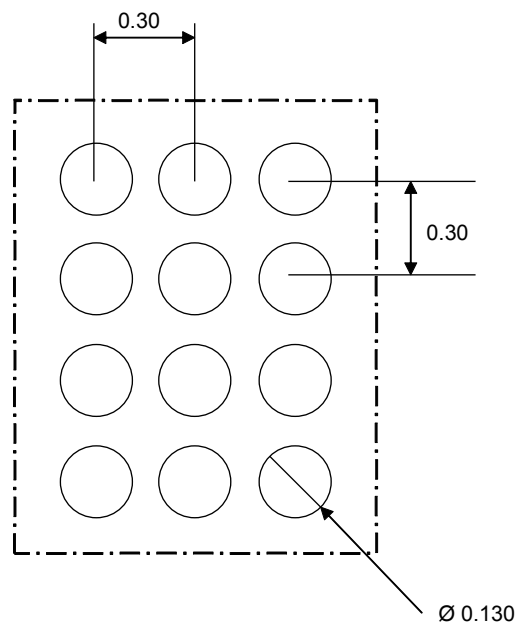
The terminal A3 on the bumps side is identified by a distinguishing feature (for instance by a circular "clear area" - typically 0.1 mm diameter - ) and/or a missing bump.

The terminal A1 on the top of the product is identified by a distinguishing feature (for instance by a circular "clear area" - typically 0.5 mm diameter - )



**Table 13. Flip-chip12 (1.1 x 1.41 mm) package mechanical data**

Dim.	mm		
	Min.	Typ.	Max.
A	0.265	0.300	0.335
A1	0,085	0,100	0,115
A2	0.180	0.200	0.220
b	0,125	0,140	0,155
D	1,06	1,11	1,16
D1		0,6	
E	1,36	1,41	1,46
E1		0,9	
e		0,3	
SE		0,15	
f		0,255	
ccc			0,020

**Figure 14. Flip-chip12 (1.1 x 1.41 mm) recommended footprint**


## 9 Ordering information

**Table 14. Ordering information**

Order code	Battery type	Package
STBC15QTR	Thin film	QFN12
STBC15LQTR <sup>(1)</sup>	Li-Ion	QFN12
STBC15JTR	Thin film	Flip-chip12
STBC15LJTR	Li-Ion	Flip-chip12

1. Available on request.

## Revision history

**Table 15. Document revision history**

Date	Revision	Changes
23-May-2018	1	Initial release.

## Contents

<b>1</b>	<b>Application schematic</b> .....	<b>2</b>
<b>2</b>	<b>Pin configuration</b> .....	<b>3</b>
<b>3</b>	<b>Maximum ratings</b> .....	<b>4</b>
<b>4</b>	<b>Electrical characteristics</b> .....	<b>5</b>
<b>5</b>	<b>Typical performance characteristics</b> .....	<b>8</b>
<b>6</b>	<b>Control pin description</b> .....	<b>10</b>
<b>7</b>	<b>Operation description</b> .....	<b>11</b>
7.1	Battery charger finite state machine (FSM) .....	11
7.2	Floating voltage selection .....	11
7.3	Charge current selection .....	12
7.4	Battery recharge .....	12
7.5	Over-discharge protection and peak mode .....	12
7.6	Shelf mode .....	13
7.7	Reverse current protection .....	13
7.8	STBC15 / STBC15L difference summary .....	13
<b>8</b>	<b>Package information</b> .....	<b>14</b>
8.1	TQFN 12 (2.00 x 1.70 mm) package information .....	14
8.2	Flip-chip12 (1.10 x 1.41 mm) package information .....	15
<b>9</b>	<b>Ordering information</b> .....	<b>18</b>
	<b>Revision history</b> .....	<b>19</b>

## List of tables

<b>Table 1.</b>	Typical bill of material (BOM) . . . . .	2
<b>Table 2.</b>	Pin description . . . . .	3
<b>Table 3.</b>	Absolute maximum ratings . . . . .	4
<b>Table 4.</b>	Thermal data . . . . .	4
<b>Table 5.</b>	Electrical characteristics . . . . .	5
<b>Table 6.</b>	STBC15 floating voltage selection . . . . .	12
<b>Table 7.</b>	STBC15L floating voltage selection . . . . .	12
<b>Table 8.</b>	Charge current selection . . . . .	12
<b>Table 9.</b>	Battery over-discharge voltages for the STBC15 . . . . .	12
<b>Table 10.</b>	Battery over-discharge voltages for the STBC15L . . . . .	13
<b>Table 11.</b>	STBC15 / STBC15L difference summary . . . . .	13
<b>Table 12.</b>	QFN12 (1.7 x 2.0 mm) package mechanical data . . . . .	15
<b>Table 13.</b>	Flip-chip12 (1.1 x 1.41 mm) package mechanical data . . . . .	17
<b>Table 14.</b>	Ordering information . . . . .	18
<b>Table 15.</b>	Document revision history . . . . .	19

## List of figures

<b>Figure 1.</b>	STBC15 application schematic . . . . .	2
<b>Figure 2.</b>	Pin connection (top through view) . . . . .	3
<b>Figure 3.</b>	$I_{CC}$ vs. temperature ( $V_{BAT} = 3.6\text{ V}$ ; $I_{OUT} = 1\text{ mA}$ ) . . . . .	8
<b>Figure 4.</b>	Floating voltage vs. temperature . . . . .	8
<b>Figure 5.</b>	Charge current vs. temperature . . . . .	8
<b>Figure 6.</b>	$R_{ON}$ M3 vs. temperature . . . . .	8
<b>Figure 7.</b>	Battery leakage current vs. $V_{BAT}$ ( $V_{CHGIN} = 0\text{ V}$ ; $V_{BAT} > V_{BAT\_OVD}$ ) . . . . .	9
<b>Figure 8.</b>	Battery leakage current vs. $V_{BAT}$ ( $V_{CHGIN} = 0\text{ V}$ ; $V_{BAT} < V_{BAT\_OVD}$ ; shelf mode) . . . . .	9
<b>Figure 9.</b>	STBC15 block diagram . . . . .	10
<b>Figure 10.</b>	Operational simplified state machine diagram . . . . .	11
<b>Figure 11.</b>	QFN12 (1.7 x 2.0 mm) package outline . . . . .	14
<b>Figure 12.</b>	QFN12 (1.7 x 2.0 mm) recommended footprint . . . . .	15
<b>Figure 13.</b>	Flip-chip12 (1.1 x 1.41 mm) package outline . . . . .	16
<b>Figure 14.</b>	Flip-chip12 (1.1 x 1.41 mm) recommended footprint . . . . .	17

**IMPORTANT NOTICE – PLEASE READ CAREFULLY**

STMicroelectronics NV and its subsidiaries (“ST”) reserve the right to make changes, corrections, enhancements, modifications, and improvements to ST products and/or to this document at any time without notice. Purchasers should obtain the latest relevant information on ST products before placing orders. ST products are sold pursuant to ST’s terms and conditions of sale in place at the time of order acknowledgement.

Purchasers are solely responsible for the choice, selection, and use of ST products and ST assumes no liability for application assistance or the design of Purchasers’ products.

No license, express or implied, to any intellectual property right is granted by ST herein.

Resale of ST products with provisions different from the information set forth herein shall void any warranty granted by ST for such product.

ST and the ST logo are trademarks of ST. All other product or service names are the property of their respective owners.

Information in this document supersedes and replaces information previously supplied in any prior versions of this document.

© 2018 STMicroelectronics – All rights reserved

# Mouser Electronics

Authorized Distributor

Click to View Pricing, Inventory, Delivery & Lifecycle Information:

[STMicroelectronics:](#)

[STBC15JTR](#)