

Hybrid motor starter - ELR H5-IES-PT- 24DC/500AC-9 - 2903906

Please be informed that the data shown in this PDF Document is generated from our Online Catalog. Please find the complete data in the user's documentation. Our General Terms of Use for Downloads are valid (<http://phoenixcontact.com/download>)



Hybrid motor starter for reversing 3~ AC motors up to 500 V AC and 9 A output current, with 24 V AC control voltage, adjustable overload shutdown and emergency stop function to SIL 3/PL e and push-in connection

Why buy this product

- ✓ 22.5 mm wide
- ✓ Safety level according to IEC 61508-1: SIL 3, ISO 13849: PL e
- ✓ Reduction in wiring
- ✓ Long service life
- ✓ Space saving
- ✓ 3-phase loop bridges
- ✓ Adjustable current for bimetal function
- ✓ Low-wear switching

Key Commercial Data

Packing unit	1 STK
GTIN	 4 046356 771290
GTIN	4046356771290
Weight per Piece (excluding packing)	273.600 g
Custom tariff number	85371098
Country of origin	Germany

Technical data

Device supply

Rated control circuit supply voltage U_s	24 V DC
Control supply voltage range	19.2 V DC ... 30 V DC
Rated control supply current I_s	40 mA
Type of protection	Surge protection
	Reverse polarity protection

Hybrid motor starter - ELR H5-IES-PT- 24DC/500AC-9 - 2903906

Technical data

Input data

Input name	Control input right/left
Rated actuating voltage U_c	24 V DC
Triggering voltage range	19.2 V DC ... 30 V DC
Rated actuating current I_c	5 mA (Input type 1)
Switching threshold	9.6 V ("0" signal)
	19.2 V ("1" signal)
Switching level	< 5 V DC (For EMERGENCY STOP)
Typical turn-off time	< 30 ms
Type of protection	Reverse polarity protection

Output data load output

Output name	AC output
Rated operating voltage U_e	500 V AC
Operating voltage range	42 V AC ... 550 V AC
Rated operating current I_e	9 A (AC-51)
	6.5 A (AC-53a)
Mains frequency	50/60 Hz
Load current range	1.5 A ... 9 A (see to derating)
Trigger characteristic in acc. with IEC 60947-4-2	Class 10A
Cooling time	20 min. (for auto reset)
Leakage current	0 mA
Type of protection	Surge protection

Output data reply output

Output name	Acknowledge output
Note	Confirmation: floating change-over contact, signal contact
Contact type	1 PDT
Switching capacity according to IEC 60947-5-1	3 A (230 V, AC15)
	2 A (24 V, DC13)

Overspeed tripping

Operate threshold	> 45 A
Response time	2 s

General

Switching frequency	≤ 2 Hz (Load-dependent)
Mounting position	vertical (horizontal DIN rail, motor output below)
Mounting type	DIN rail mounting
Assembly instructions	alignable, for spacing see derating
Operating mode	100% operating factor
Maximum power dissipation	7 W
Minimum power dissipation	0.88 W
Operating voltage display	Green LED

Hybrid motor starter - ELR H5-IES-PT- 24DC/500AC-9 - 2903906

Technical data

General

Status display	Yellow LED
Indication	Red LED

Connection data, input side

Connection name	Control circuits
Connection method	Push-in connection
Stripping length	10 mm
Conductor cross section solid	0.2 mm ² ... 2.5 mm ²
Conductor cross section flexible	0.2 mm ² ... 2.5 mm ²
Conductor cross section AWG	24 ... 14

Connection data, output side

Connection name	Load circuit
Connection method	Push-in connection
Stripping length	10 mm
Conductor cross section solid	0.2 mm ² ... 2.5 mm ²
Conductor cross section flexible	0.2 mm ² ... 2.5 mm ²
Conductor cross section AWG	24 ... 14

Ambient conditions

Ambient temperature (operation)	-25 °C ... 70 °C (observe derating)
Ambient temperature (storage/transport)	-40 °C ... 80 °C
Degree of protection	IP20

Dimensions

Width	22.5 mm
Height	107.4 mm
Depth	113.7 mm

UL data

SCCR	100 kA (500 V AC (fuse: 30 A class CC/30 A class J (high fault)))
	5 kA (500 V AC (fuse: 20 A RK5 (standard fault)))
FLA	6.5 A (500 V AC)
Group installation	20 A (class RK5, SCCR 5kA, #24 - 14 AWG max. solid and stranded)
	30 A (class CC or J, SCCR 100kA, #24 - 14 AWG max, solid and stranded)
Category code	NLDX

Insulation characteristics

Rated insulation voltage	500 V
Rated surge voltage	6 kV
Overvoltage category	III
Degree of pollution	2
Designation	Insulation characteristics between the control input and control supply voltage, and auxiliary circuit to the main circuit

Hybrid motor starter - ELR H5-IES-PT- 24DC/500AC-9 - 2903906

Technical data

Insulation characteristics

Insulation	Safe isolation (IEC 60947-1/EN 50178) at operating voltage ≤ 300 V AC
	Basic isolation (IEC 60947-1) at operating voltage 300 ... 500 V AC
	Safe isolation (EN 50178) at operating voltage 300 ... 500 V AC
Designation	Isolation characteristics between the control input and control supply voltage to auxiliary circuit
Insulation	Safe isolation (IEC 60947-1) in the auxiliary circuit ≤ 300 V AC
	Safe isolation (EN 50178) in the auxiliary circuit ≤ 300 V AC

Standards and Regulations

Designation	Standards/regulations
Standards/regulations	IEC 60947-1
	IEC 60947-4-2
	IEC 61508
	ISO 13849
ATEX	# II (2) G [Ex e] [Ex d] [Ex px]
	# II (2) D [Ex t] [Ex p]

Approvals/conformities

Safety Integrity Level according to IEC 61508	≤ 3 (Safe shutdown)
	2 (Motor protection)
Category acc. to EN ISO 13849	≤ 3 (Safe shutdown)
Performance level according to ISO 13849	$\leq e$ (Safe shutdown)
ATEX	# II (2) G [Ex e] [Ex d] [Ex px]
	# II (2) D [Ex t] [Ex p]
EU-type examination certificate	PTB 07 ATEX 3145
UL certificate	NLDX.E228652

Environmental Product Compliance

China RoHS	Environmentally Friendly Use Period = 50
	For details about hazardous substances go to tab "Downloads", Category "Manufacturer's declaration"

Drawings

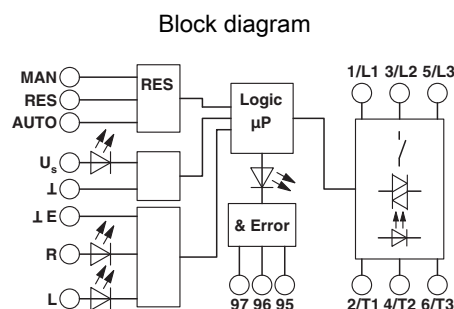
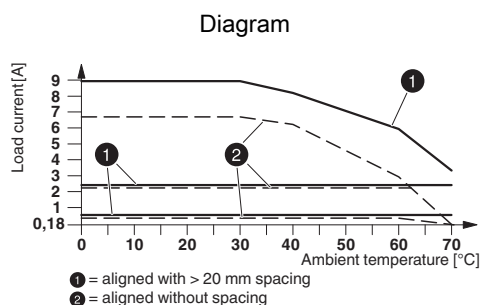

Derating diagram

Hybrid motor starter - ELR H5-IES-PT- 24DC/500AC-9 - 2903906

Circuit diagram

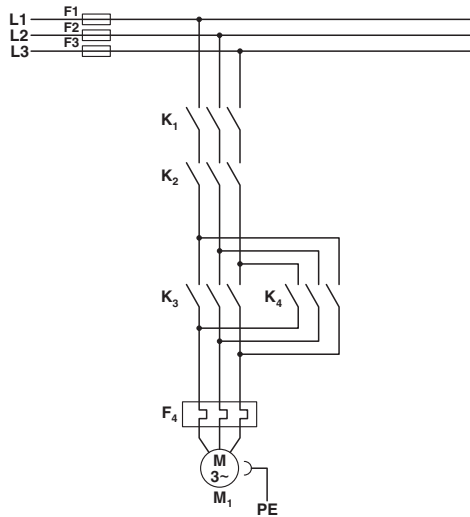

Conventional structure
Main current path for reversing contactor according to category 3

- K1 + K2 = Emergency stop contactor
- K3 = Left contactor
- K4 = Right contactor
- F4 = Motor protection relay

Circuit diagram

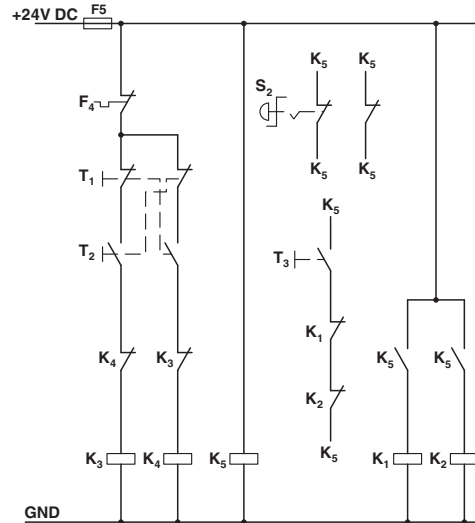

Conventional structure
Control current path reversing contactor according to category 3

- K1 + K2 = Emergency stop contactor
- K3 = Left contactor
- K4 = Right contactor
- K5 = PSR SCP-24DC.../Safety relay
- T1 = Right, T2 = Left, T3 = Reset
- S2 = Emergency stop
- F4 = Motor protection relay

Circuit diagram

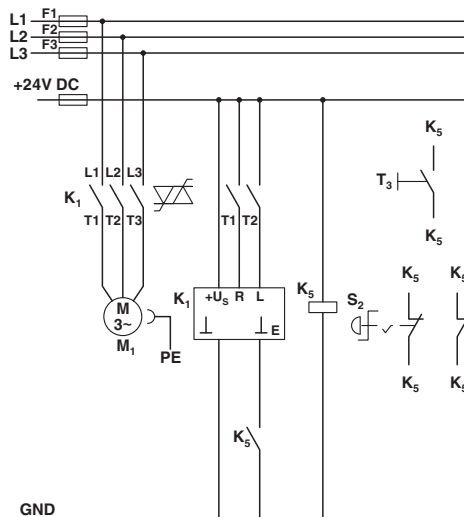

Structure with CONTACTRON
Main and control current path for '4 in 1' hybrid motor starter with reversing function according to category 3
K1 = '4 in 1' hybrid motor starter with reversing function

Hybrid motor starter - ELR H5-IES-PT- 24DC/500AC-9 - 2903906

K5 = PSR SCP-24DC.../Safety relay
 T1 = Right, T2 = Left, T3 = Reset
 S2 = Emergency stop

Classifications

eCl@ss

eCl@ss 5.0	27024002
eCl@ss 5.1	27024002
eCl@ss 6.0	27024002
eCl@ss 7.0	27024002
eCl@ss 8.0	27024002
eCl@ss 9.0	27024002

ETIM

ETIM 2.0	EC001037
ETIM 3.0	EC001037
ETIM 4.0	EC001037
ETIM 5.0	EC001037
ETIM 6.0	EC001037

UNSPSC

UNSPSC 6.01	30211915
UNSPSC 7.0901	39121514
UNSPSC 11	39121514
UNSPSC 12.01	39121514
UNSPSC 13.2	25173902

Approvals

Approvals

Approvals

UL Listed / cUL Listed / IECCEB Scheme / UL Listed / cUL Listed / EAC / CCC / cULus Listed

Ex Approvals

ATEX

Approval details

UL Listed		http://database.ul.com/cgi-bin/XYV/template/LISEXT/1FRAME/index.htm	FILE E 323771
-----------	---	---	---------------

Hybrid motor starter - ELR H5-IES-PT- 24DC/500AC-9 - 2903906

Approvals

cUL Listed		http://database.ul.com/cgi-bin/XYV/template/LISEXT/1FRAME/index.htm	FILE E 228652
------------	--	---	---------------

IECEE CB Scheme		http://www.iecee.org/	DE1-55728
-----------------	--	---	-----------

UL Listed		http://database.ul.com/cgi-bin/XYV/template/LISEXT/1FRAME/index.htm	FILE E 228652
-----------	--	---	---------------

cUL Listed		http://database.ul.com/cgi-bin/XYV/template/LISEXT/1FRAME/index.htm	FILE E 323771
------------	--	---	---------------

EAC			RU C- DE.A*30.B.01082
-----	--	--	--------------------------

CCC		http://www.china-certification.com	2016010304871315
-----	--	---	------------------

cULus Listed			
--------------	--	--	--

Accessories

Accessories

Cover

Covering hood - BRIDGE COVER - 2906240



The BRIDGE COVER covering hood is used to cover unused plugs on the CONTACTRON bridge that may subsequently be used to extend the system. The hood can be used with the screw and Push-in version of the bridge.

Device marking

Hybrid motor starter - ELR H5-IES-PT- 24DC/500AC-9 - 2903906

Accessories

Plastic label - US-EMLP (15X5) - 0828790



Plastic label, Card, white, unlabeled, can be labeled with: THERMOMARK PRIME, THERMOMARK CARD, BLUEMARK ID, BLUEMARK ID COLOR, mounting type: adhesive, lettering field size: 15 x 5 mm

Plastic label - UC-EMLP (15X5) - 0819301



Plastic label, Sheet, white, unlabeled, can be labeled with: BLUEMARK ID, BLUEMARK ID COLOR, BLUEMARK CLED, BLUEMARK LED, CMS-P1-PLOTTER, PLOTMARK, mounting type: adhesive, lettering field size: 15 x 5 mm

Loop bridge

Jumper - BRIDGE-PT 2 - 2904490



3-phase loop bridge for 2 CONTACTRON modules, with push-in connection and 22.5 mm housing width, connecting cable: 3 m, with ferrules included.

Jumper - BRIDGE-PT 3 - 2904491



3-phase loop bridge for 3 CONTACTRON modules, with push-in connection and 22.5 mm housing width, connecting cable: 3 m, with ferrules included.

Jumper - BRIDGE-PT 4 - 2904492



3-phase loop bridge for 4 CONTACTRON modules, with push-in connection and 22.5 mm housing width, connecting cable: 3 m, with ferrules included.

Hybrid motor starter - ELR H5-IES-PT- 24DC/500AC-9 - 2903906

Accessories

Jumper - BRIDGE-PT 5 - 2904493



3-phase loop bridge for 5 CONTACTRON modules, with push-in connection and 22.5 mm housing width, connecting cable: 3 m, with ferrules included.

Jumper - BRIDGE-PT 6 - 2904494



3-phase loop bridge for 6 CONTACTRON modules, with push-in connection and 22.5 mm housing width, connecting cable: 3 m, with ferrules included.

Jumper - BRIDGE-PT 7 - 2904495



3-phase loop bridge for 7 CONTACTRON modules, with push-in connection and 22.5 mm housing width, connecting cable: 3 m, with ferrules included.

Jumper - BRIDGE-PT 8 - 2904496



3-phase loop bridge for 8 CONTACTRON modules, with push-in connection and 22.5 mm housing width, connecting cable: 3 m, with ferrules included.

Jumper - BRIDGE-PT 9 - 2904497



3-phase loop bridge for 9 CONTACTRON modules, with push-in connection and 22.5 mm housing width, connecting cable: 3 m, with ferrules included.

Hybrid motor starter - ELR H5-IES-PT- 24DC/500AC-9 - 2903906

Accessories

Jumper - BRIDGE-PT 10 - 2904498



3-phase loop bridge for 10 CONTACTRON modules, with push-in connection and 22.5 mm housing width, connecting cable: 3 m, with ferrules included.

Phoenix Contact 2018 © - all rights reserved
<http://www.phoenixcontact.com>