

Servosila SC-25 Brushless/Brushed Motor Controllers

Datasheet

Revision G (April 2023)

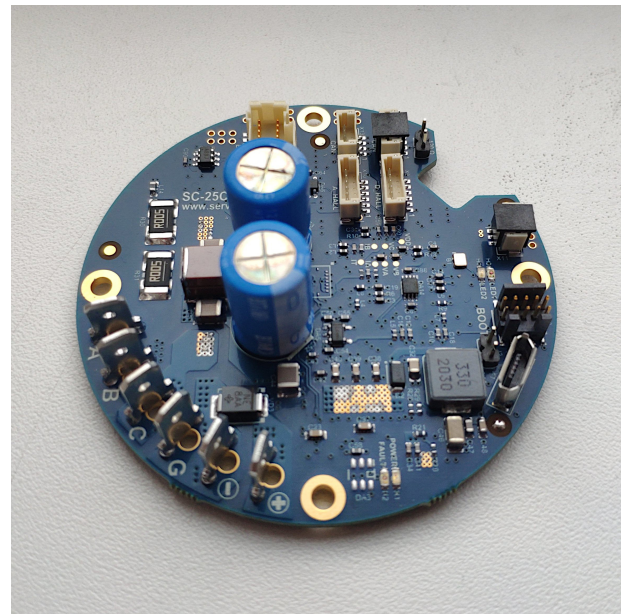
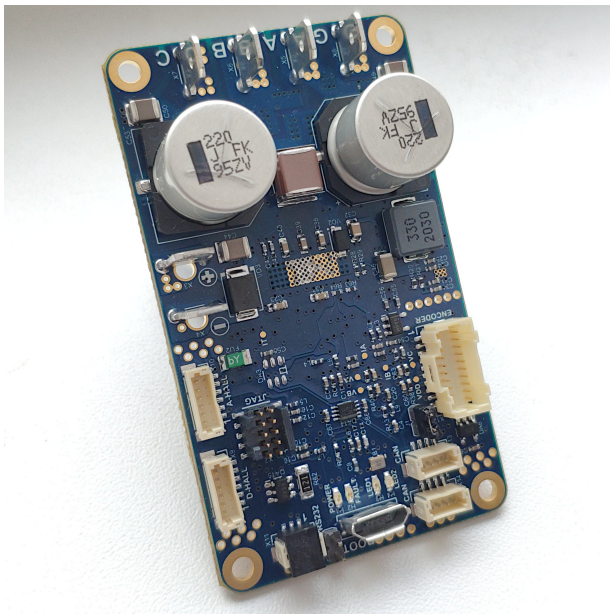

www.servosila.com/en/motion-control

Table of Contents

Introduction.....	4
Servosila SC-25R: Layout.....	5
Servosila SC-25C: Layout.....	6
Electrical Connectors & Part Numbers.....	7
Jumpers.....	8
LEDs.....	8
First pin & Soldering Holes.....	8
ENCODERS connector.....	9
Schematics.....	9
Pins.....	9
SSI/BISS-C.....	10
SPI.....	10
PWM Input Interface.....	11
Quadrature Interface.....	11
Hall Sensors connector (D HALL).....	12
Schematics.....	12
Pins.....	12
CAN bus connectors (CAN A, CAN B).....	13
Schematics.....	13
Firmware re-flashing port (RS232).....	14
Schematics.....	14
Pins.....	14
GPIO input/output.....	15

Available GPIO pins.....	15
Schematics: controlling an External Brake via GPIO output.....	16
Schematics: Limit Switch or Emergency Stop.....	17
Receiving an RC PWM control signal.....	17
Power Supply.....	18
Power Output.....	18
Mounting.....	18
Specifications.....	19
Selection Criteria for Brushless Motor.....	21

Introduction

Servosila SC-25 Brushless/Brushed Motor Controllers come in two form factors, a rectangular one (SC-25R) and a circular one (SC-25C). Both models are identical in terms of capabilities, features, firmware, and external electrical connectors. Industrial designers might prefer one model over the other depending on what actuated mechanisms they are working on. At the same time, both electrical and software engineers rest assured that whichever model is chosen for a particular design, a full electrical and software compatibility is still in place.

The controllers come with pre-soldered connectors (Molex & TE Connectivity) for attaching phase lines, power lines, sensors, encoders, and information buses. Besides the connectors, the controllers come with **soldering holes** for every signal or power line. The soldering holes allow cables to be soldered directly to the boards to form vibration-resistant connections.

All connectors are intentionally placed on the front side of the boards only. There are no connectors on the back side of the boards. The back side is intended for installation of an (optional) heat sink, or for attaching the boards directly to an enclosure designed to act as a heat sink.

All the connectors are facing upwards, perpendicular to the boards. None of the connectors are facing sideways. This arrangement simplifies cable routing within cramped spaces such as cylindrical enclosures of servo drives or mobile chassis.

The electric motor controllers feature two identical parallel CAN bus ports. This simplifies cabling of multiple controllers into a chain, for example, inside a robotic arm manipulator or a robotic chassis, and streamlines in-the-field repair or replacement process.

The controllers come with an on-board terminal 120 Ohm resistor prescribed by the CAN bus standard. The resistor can be turned on or off via a jumper. Only one controller in a chain needs to have the terminal resistor enabled.

There is a way to upgrade the controllers' firmware via a RS232 port, including field firmware upgrades of servo drives or mobile vehicles.

Servosila SC-25R: Layout

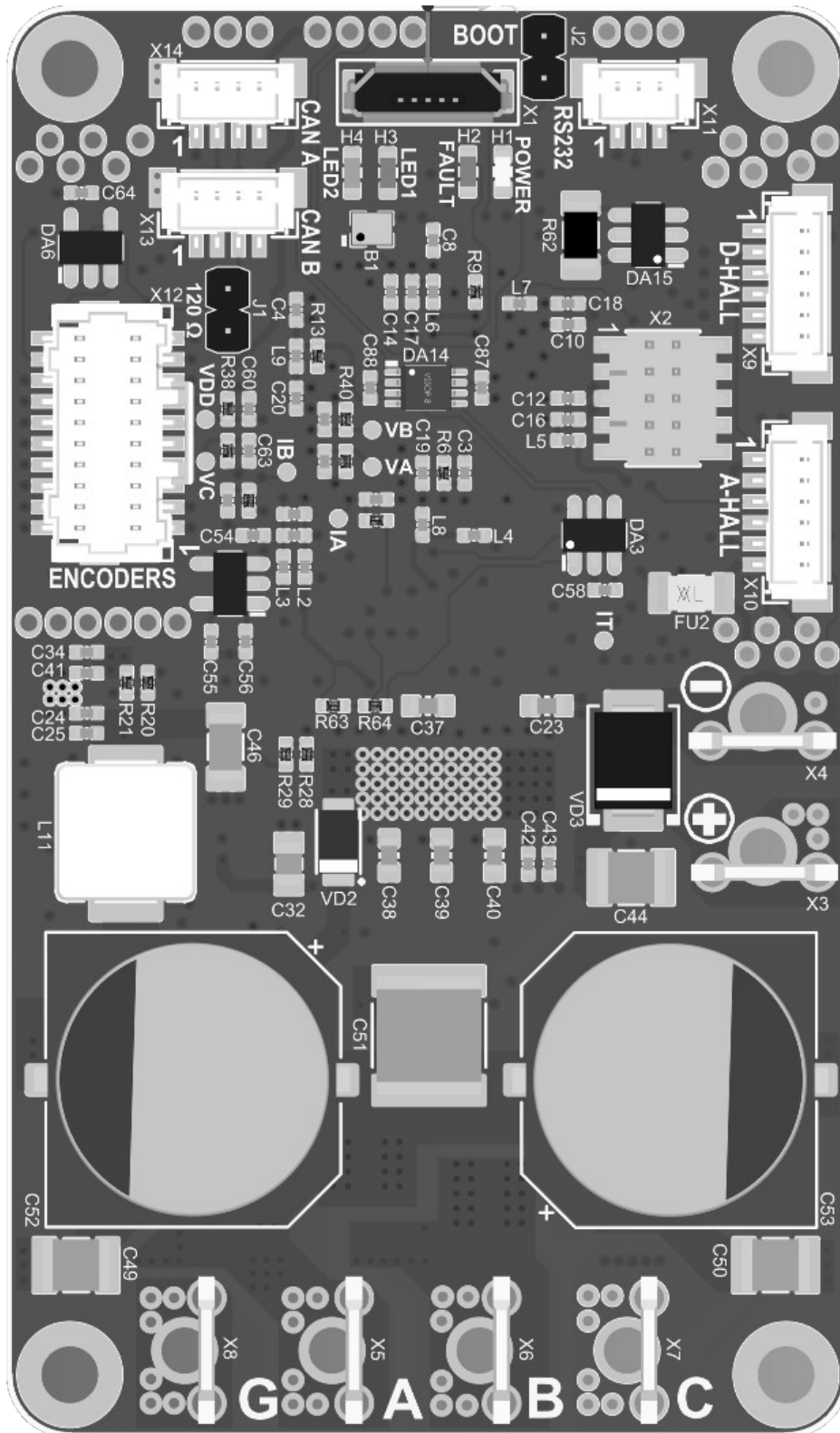

Figure 1: SC-25R – Front Side

Servosila SC-25C: Layout

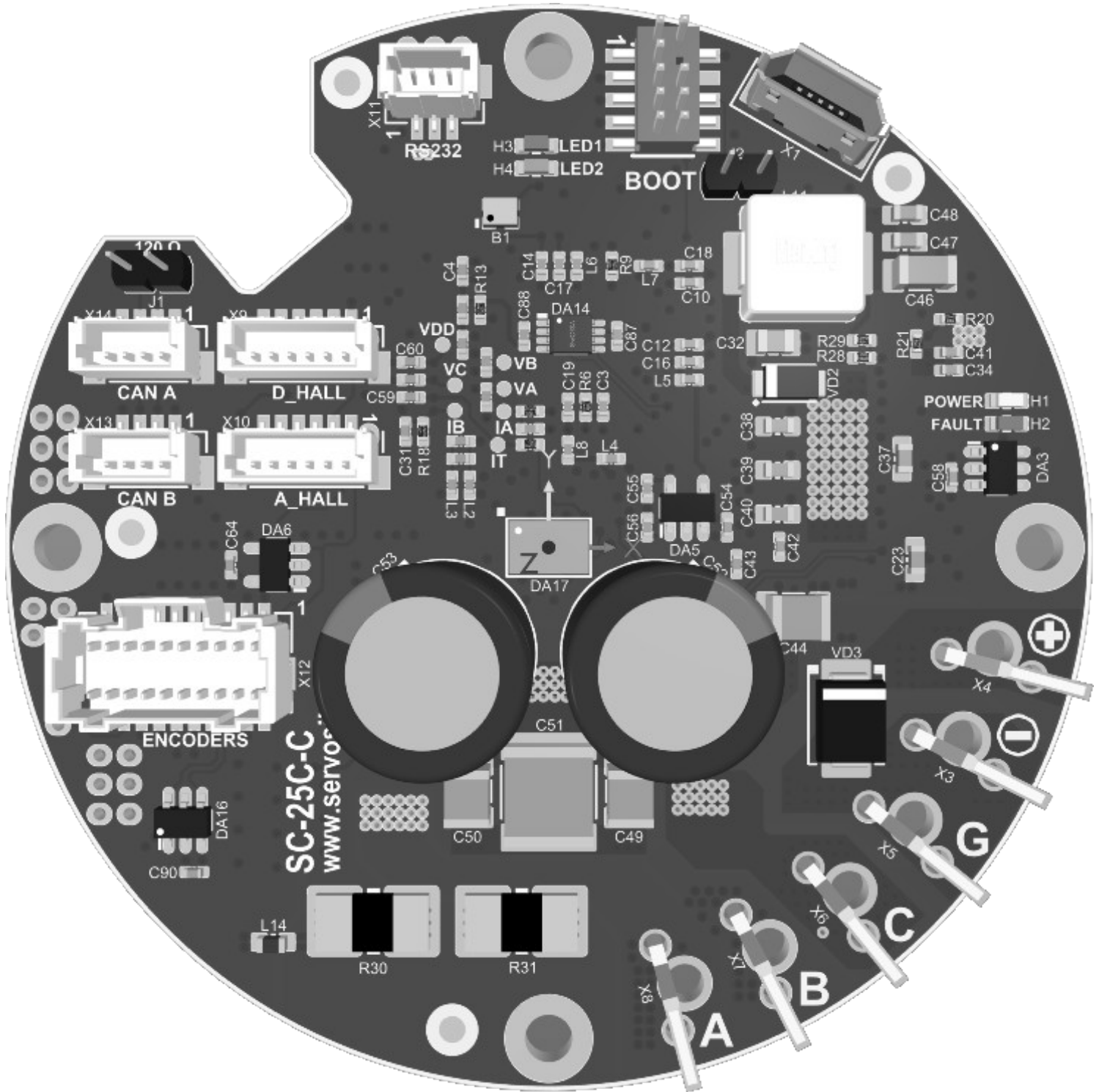

Figure 2: SC-25C – Front Side

Electrical Connectors & Part Numbers

ID	Label	Purpose	Part #	Mates to Part #
X12	ENCODERS	SSI, BISS-C, SPI, PWM input, Quadrature input <i>Alternative purposes: GPIO limit switches, emergency stop, dedicated input or output pins.</i>	Molex 5011902027	Molex 5011892010
X14	CAN A	CAN bus port A (parallel to port CAN B)	TE Connectivity AMP Connectors 1734595-4	TE Connectivity AMP Connectors 1470364-4
X13	CAN B	CAN bus port B (parallel to port CAN A)	TE Connectivity AMP Connectors 1734595-4	TE Connectivity AMP Connectors 1470364-4
X1	USB	USB2.0 MICRO B port	Würth Elektronik 614105150721	USB2.0 MICRO B male
X11	RS232	Firmware re-flashing port	TE Connectivity AMP Connectors 1734595-3	TE Connectivity AMP Connectors 1470364-3
X9	D HALL	Hall Sensors (discrete) <i>Alternative purposes: GPIO limit switches, emergency stop, dedicated input or output pins.</i>	TE Connectivity AMP Connectors 1734595-6	TE Connectivity AMP Connectors 1470364-6
X10	A HALL	Not used (firmware-specific)	same	same
X4	-	Power Supply Negative (<i>polarity sensitive!</i>)	TE Connectivity AMP Connectors 1-726388-2	TE Connectivity AMP Connectors 2293255-1
X3	+	Power Supply Positive (<i>polarity sensitive!</i>)	same	same
	G	Brushless Motor Ground	same	same
	A	Brushless Motor Phase A <i>or Brushed Motor “+”</i>	same	same
	B	Brushless Motor Phase B <i>or Brushed Motor “-”</i>	same	same
	C	Brushless Motor Phase C	same	same

Jumpers

ID	Label	Purpose	Part #
J1	120 Ohm	The jumper turns on (once installed) a 120 Ohm terminal resistance required by the CAN bus. Install the jumper on one of the controllers in a CAN network.	Sullins Connector Solutions SPN02SYBN-RC
J2	Boot	The jumper (once installed) switches the controller into a firmware re-flashing mode. Do not forget to remove the jumper after finishing the re-flashing procedure!	same

LEDs

ID	Label	Purpose
H1	POWER	This LED is directly wired to power supply lines. The LED turns on whenever a power supply is connected to “+” and “-” terminals of the controller.
H2	FAULT	This LED turns on whenever firmware detects a fault or multiple simultaneous faults. A telemetry parameter “Fault Bits” tells what faults have caused the problem. Note that the firmware latches into a FAULT mode before turning the LED on. In this mode, the motor is de-energized and the firmware stops responding to any command rather than the RESET command. Send a RESET command to the controller in order to clear the fault latches and switch the controller back into an operational mode once the fault is rectified.
H3	LED1	The LED turns on whenever the controller receives a command from a parent control system via either CAN or USB. The LED indicates that a parent control system is successfully communicating to the controller.
H4	LED2	Not used (firmware-specific)

First pin & Soldering Holes

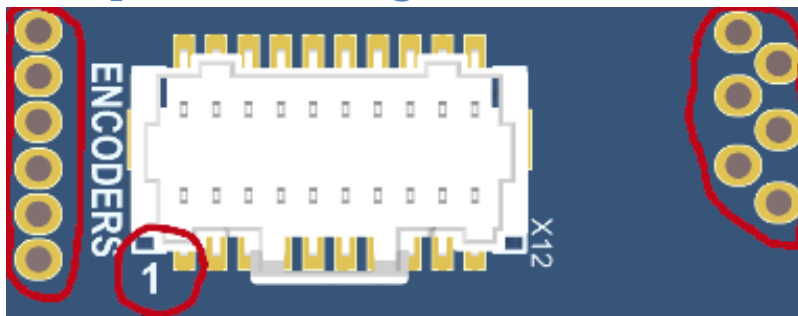

First pin of every connector is labeled with a “1” sign.

The controllers come with **soldering holes** for every signal or power line. The soldering holes allow cables to be soldered directly to the boards from either side to form vibration-resistant connections. Use a multimeter to match pins vs. soldering holes (“buzz the circuit”).

ENCODERS connector

The ENCODERS connector is intended for connecting absolute position encoders via digital interfaces. The supported interfaces are SSI, BISS-C (unidirectional), SPI, Quadrature (single-ended), or PWM.

Note that SPI, Quadrature and PWM interfaces share pins. In contrast, the SSI/BISS-C interface comes with a dedicated set of pins. This interface can be used together with other encoder interfaces such as SPI, PWM or Quadrature. If two encoders are to be simultaneously connected to the same SC-25 controller, one of the encoders must use SSI/BISS-C interface since the other interfaces share pins.

Schematics

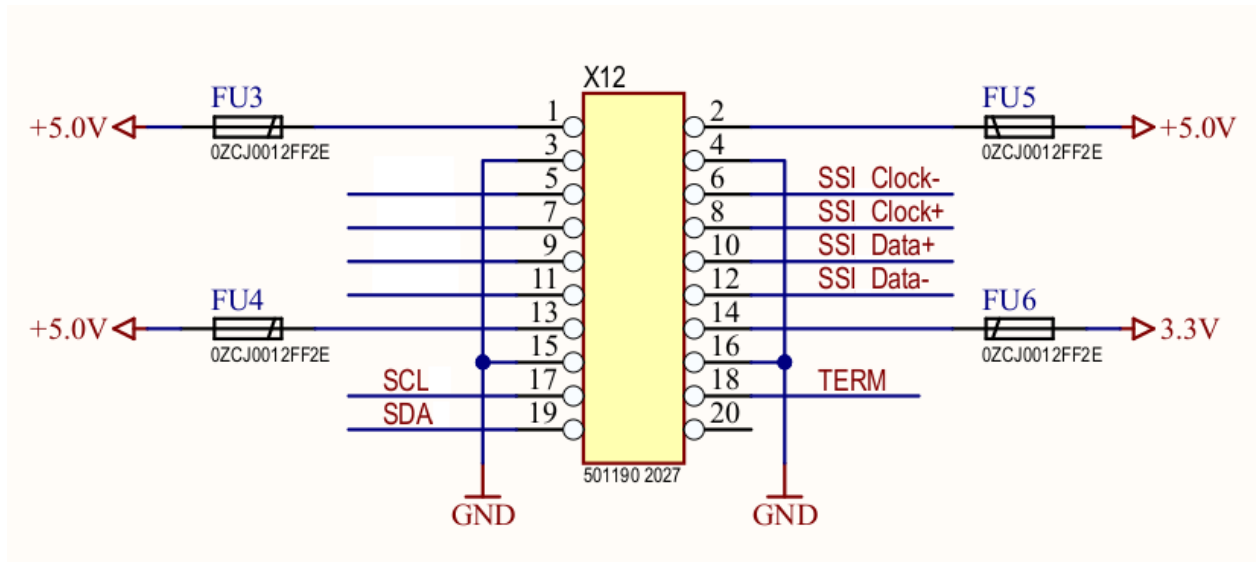

Pins

Pin #	Purpose	Pin #	Purpose
1	+5.0 (power output , fuse-protected)	2	+5.0 (power output , fuse-protected)
3	GND	4	GND
5	Quadrature "A" or SPI SOMI	6	SSI bus Clock-
7	Quadrature "B" or SPI CLK	8	SSI bus Clock+
9	Quadrature Index ("Z") or SPI SS (Slave Select) or PWM input	10	SSI bus Data+
11	SPI SIMO	12	SSI bus Data-

13	+5.0 (power output , fuse-protected)	14	+5.0 (power output , fuse-protected)
15	GND	16	GND
17	I2C bus SCL (not used, firmware-specific) <i>This pin can be used for GPIO output (5V)</i>	18	Thermistor input (not used, firmware-specific)
19	I2C bus SDA (not used, firmware-specific) <i>This pin can be used for GPIO output (5V)</i>	20	Not used

SSI/BISS-C

Wire	Pin #	Description
+5.0V	2	Power output , fuse-protected
GND	4	Ground
Clock-	6	Clock, differential
Clock+	8	Clock, differential
Data+	10	Data, differential
Data-	12	Data, differential

The BISS-C interface is unidirectional. Maximum supported output clock frequency is 12.5 MHz.

SPI

Wire	Pin #	Description
+5.0V	1	Power output , fuse-protected
GND	3	Ground
SOMI	5	Slave output, master input
CLK	7	Clock
SS	9	Slave select
SIMO	11	Slave input, master output (not used, firmware-specific)

Maximum supported output clock frequency is 12.5 MHz.

PWM Input Interface

Wire	Pin #	Description
+5.0V	1	Power output , fuse-protected
GND	3	Ground
PWM	9	PWM input signal

Maximum input pulse frequency is 5MHz.

Quadrature Interface

Wire	Pin #	Description
+5.0V	1	Power output , fuse-protected
GND	3	Ground
A	5	Signal “A”
B	7	Signal “B”
I	9	Index Signal (signal “Z”)

Both “push-pull” and “open collector” connections are supported.

The quadrature interface is “single-ended” (not a “differential” one). In order to connect an encoder with “differential” signals, connect just one of the wires in each pair. Try “inverted” signal first; if it does not work, try the normal signal next. Use telemetry to verify received signals.

Maximum input pulse frequency is 5MHz.

Input signal voltages:

- Less than 0.4V is logical “low”,
- More than 2.4V is logical “high”.

Hall Sensors connector (D HALL)

Schematics

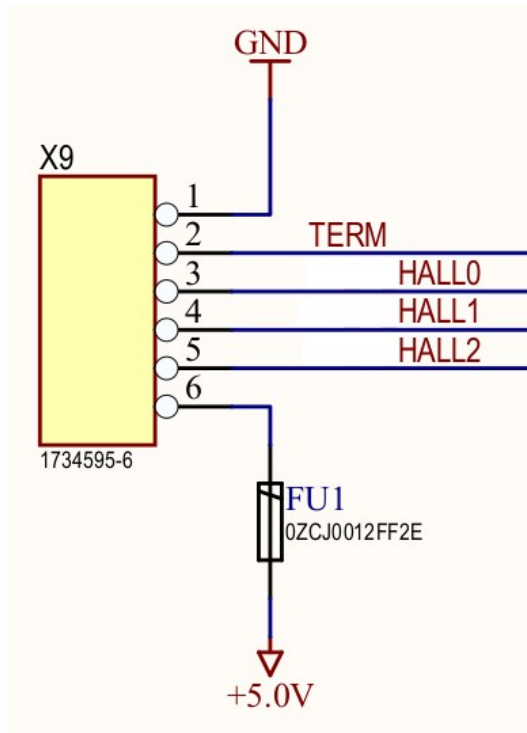

Pins

Pin #	Purpose
1	Ground
2	Thermistor input (not used, firmware-specific)
3	Hall signal 0 (discrete)
4	Hall signal 1 (discrete)
5	Hall signal 2 (discrete)
6	+5.0V, power supply

The Hall Sensors interface is “single-ended” (not a “differential” one). Both “push-pull” and “open collector” connections are supported.

CAN bus connectors (CAN A, CAN B)

The electric motor controllers feature two identical parallel CAN bus ports. This simplifies cabling of multiple controllers into a chain, for example, inside a robotic arm manipulator or a robotic chassis, and streamlines in-the-field repair or replacement process.

The controllers come with an on-board terminal 120 Ohm resistor prescribed by the CAN bus standard. The resistor can be turned on or off via a jumper. Only one controller in a chain needs to have the terminal resistor enabled.

Schematics

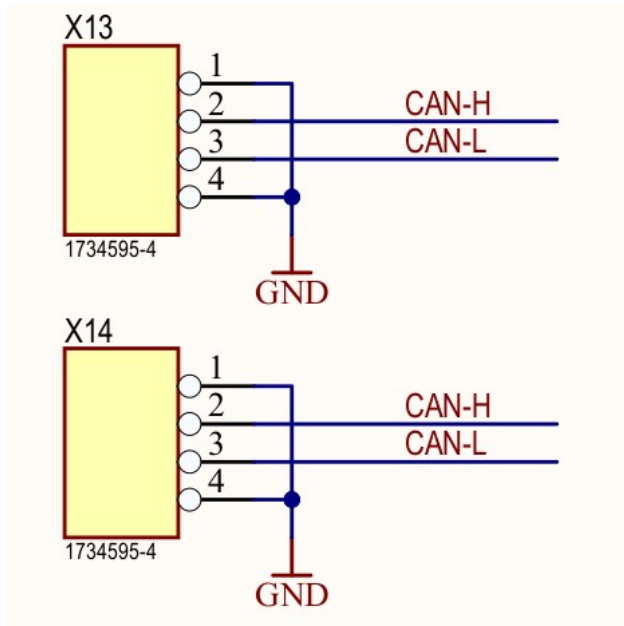

Pins

Pin #	Purpose
1	Ground
2	CAN high
3	CAN low
4	Ground

Supported bit rates are 1 mbit/sec, 500 kbit/sec, 250 kbit/sec, 125 kbit/sec, 100 kbit/sec, and 50 kbit/sec.

Firmware re-flashing port (RS232)

The RS232 port is used for re-flashing the controller's firmware. The port is not used for anything else.

Schematics

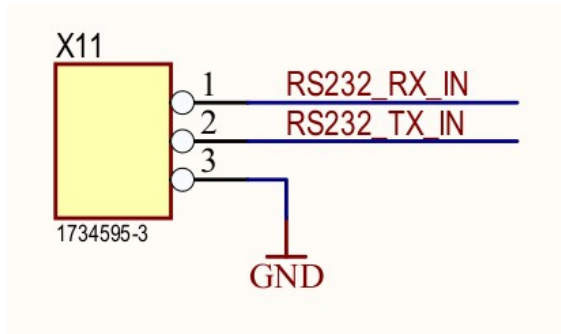

Pins

Pin #	Purpose
1	RX, serial receive
2	TX, serial transmit
3	Ground

GPIO input/output

Available GPIO pins

The SC25 controllers do not have dedicated GPIO pins or connectors. However, unused pins in ENCODERS connector or Hall Sensors connector (D HALL) can be re-purposed to perform input-output functions. Thus, a different selection of free pins is available for performing GPIO functions depending on what encoder interface is used and on whether or not a motor comes with Hall sensors.

Use the following tables to determine which pins are available for GPIO purposes, and what GPIO numbers correspond to particular pins.

Note:

- The GPIO numbers listed in the tables below are needed when configuring GPIO functions such as limit switches, emergency stop, or generic input/output functions in Servoscope software.
- If a GPIO pin is used as an *output* pin, an **external resistor** should be added into the circuit. The tables below provide nominal values for the resistors. Refer to a schematics diagram below.

Pin in ENCODERS connector	Direction	Primary purpose	GPIO number	External resistor	Output Voltage
				<i>if used as GPIO output</i>	<i>if used as GPIO output</i>
8	output only	SSI Clock+	GPIO14	3.3kOhm	3.3V
10	input only	SSI Data+	GPIO13	2kOhm	
5	output, input	SPI MISO or Quadrature A	GPIO17	2kOhm	3.3V
7	output, input	SPI CLK or Quadrature B	GPIO18	2kOhm	3.3V
9	output, input	SPI CS or Quadrature I or PWM input	GPIO19	2kOhm	3.3V
11	output, input	SPI SIMO	GPIO16	2kOhm	3.3V
17	output only	I2C SCLA	GPIO33	0 Ohm	5 V
19	output only	I2C SDAA	GPIO32	0 Ohm	5 V

(continued ...)

Pin in D_HALLS connector	Direction	Primary purpose	GPIO number	External resistor <i>if used as GPIO output</i>	Output Voltage <i>if used as GPIO output</i>
3	output, input	Hall 0	GPIO11	2kOhm	3.3V
4	output, input	Hall 1	GPIO7	2kOhm	3.3V
5	output, input	Hall 2	GPIO9	2kOhm	3.3V

Schematics: controlling an External Brake via GPIO output

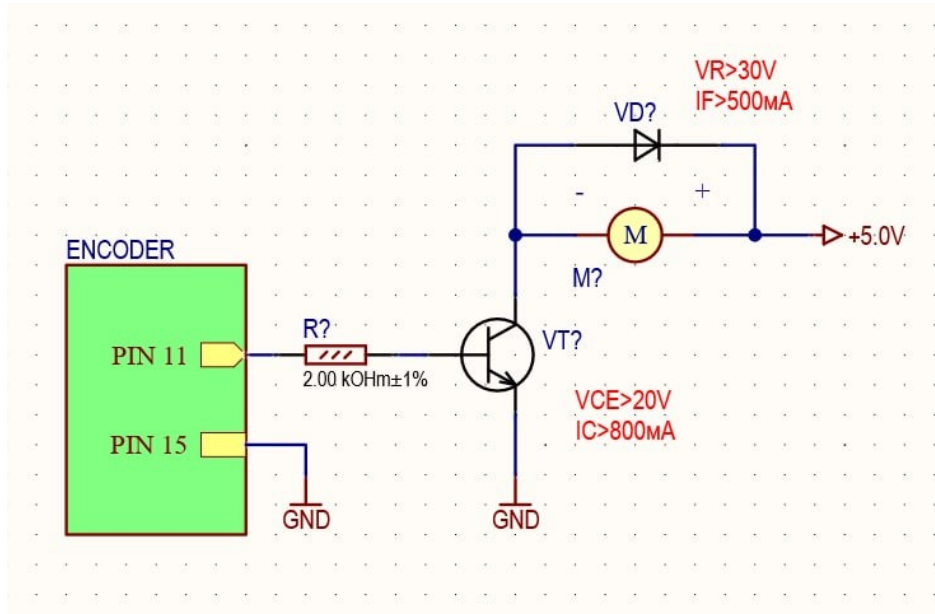

The diagram shows how to connect an external brake/solenoid to one of [GPIO output](#) pins. Choose either a 3.3V or a 5V output-capable pin.

Note: the nominal value of the resistor depends on the chosen pin. Refer to tables above for proper selection of the nominal value.

Schematics: Limit Switch or Emergency Stop

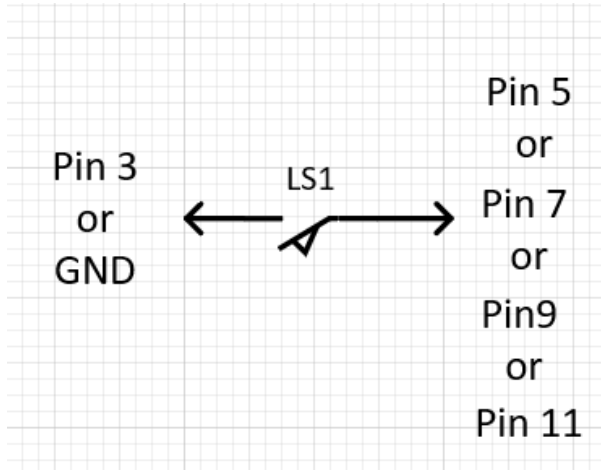

The diagram demonstrates a way to connect a Limit Switch or Emergency Stop via pins in ENCODERS connector. A similar approach works with pins of the D HALLS connector.

Receiving an RC PWM control signal

The SC25 controllers are capable of receiving a PWM control signal from an RC receiver such as Futaba or from a PLC with PWM output. A *duty cycle* of the PWM signal is used as a control input for speed control or servo control.

Note:

- **Common ground (!!!):** Interconnected SC25 controller and RC receiver/PLC **must** have a common ground.
- The input PWM signal should have 5V amplitude. It *may* work with 3.3 V signal.

There are two options for connecting a cable carrying an RC PWM signal. It can be connected to either D_HALL connector or to ENCODERS connector as shown in the table below:

OPTION #1: D_HALL connector	OPTION #2: ENCODERS connector
Pin 1: connect to GND wire of RC receiver/PLC	Pin 3: connect to GND wire of RC receiver/PLC
Pin 4: connect to PWM output wire of RC receiver/PLC	Pin 9: connect to PWM output wire of RC receiver/PLC

Power Supply

The controllers require 7.0 – 60.0 V DC power input. The controllers come with built-in high-capacity filters for the power input. There are terminals as well as soldering holes (soldering contacts) for connecting power supply lines in a vibration-resistant way.

The power supply terminals are polarity sensitive.

Power Output

The SC-25 controllers can provide power to external modules such as encoders using +5.0V and GND output pins as well as via dedicated soldering holes (soldering contacts).

The nominal output current is 0.150 A at 5.0V.

The output power lines are protected by fuses set at 0.300 A. The fuses are reset by power-cycling the controller.

Mounting

Suggested bolts are DIN912 M2.5 or DIN84 M2.5.

Specifications

Parameter	Description
Supported kinds of electric motors	Brushless DC Motors (PMSM, BLDC). Sensorless or Sensorless. Brushed Motors (Full Support including ESC & Servo mode)
Number of simultaneously connected motors: - brushless motors - brushed motors or solenoids	1 brushless motor, or up to 2 brushed motors or solenoids
Max. phase-to-phase current	25 A (heat sink recommended)
Nominal phase-to-phase current	15 A (a heat sink is recommended, but usually not required), 12 A, no heat sink
Input voltage	7-60 V DC
Operation modes	Electronic Torque Control (ETC), Electronic Speed Control (ESC), Servo Control, Direct Drive Control. Brake, Energy Recuperation, Auto-Configuration/System Identification
Supported algorithms of brushless motor control	Field-Oriented Control (FOC), EMF Observer (“Sensorless Control”), Hall Sensors Observer, D-Q axis Coupling Compensation, Field Weakening, Protections, Motor dynamics management
Auto configuration (system identification) function	Yes
Hall Sensors input (discrete)	Yes (“single-ended”)
Interfaces to absolute position encoders	BISS-C (unidirectional), SSI, SPI, PWM, Quadrature with Index Signal (“single-ended”)

Max. resolution of encoder	20 bit
Built-in network router	Built-in USB-to-CAN router («USB2CAN dongle»). Both 11bit and 29bit identifiers are supported by the routing function.
Control Interfaces	CAN bus with CANopen application protocol. USB 2.0, a virtual COM port, with SLCAN application protocol. RC PWM control interface
CANbus Terminal Resistor 120 Ohm	Yes (jumper controlled)
Supported CANbus bit rates	1 mbit/sec 500 kbit/sec 250 kbit/sec 125 kbit/sec 100 kbit/sec 50 kbit/sec
CANbus ports	2 (parallel)
USB 2.0 ports	1
GPIO functions	2x Limit Switch inputs 1x Emergency Stop input 1x dedicated GPIO output (discrete or PWM signal) 1x dedicated GPIO input (discrete)
Supported operating systems	Linux (no driver is needed) including Debian, Ubuntu Windows 11 (no driver is needed) Windows 10 (no driver is needed) Windows 8 (no driver is needed) Windows 7 (driver is provided)
Programming APIs	Linux SocketCAN API, CANopen, SLCAN protocol via a virtual COM-port (USB2.0) for Windows 11, 10, 8, 7 and Linux.
Software Electric Drive Simulator	Yes
Dimensions: - Model SC-25R (rectangular) - Model SC-25C (circular)	68mm x 40mm x 16mm Diameter: 62 mm, height: 16 mm
Weight	~50 g
Power consumption when idling	120-180 mA

Selection Criteria for Brushless Motor

The SC25 controllers are capable of controlling a wide range of brushless motors. However, there are certain limitations on the brushless motors' specifications. Use the following rules when selecting a brushless motor for use with SC25 controller.

Rule #1: Current Limits

Nominal current < 15A. Maximum current < 32A

If your motor has higher nominal current than the provided value, the motor will likely not work well with SC25 controller.

Rule #2: Electrical Time Constant Limit

Verify that $L/R > 0.00035$

where **L** is a phase-to-phase inductance, and **R** is a phase-to-phase resistance. Get these from the motor's datasheet.

If the ratio is less than the specified value, then the motor is not likely to work well with the SC25 controller.

Rule #3: Max Speed Limit

Verify that $(RPM/60) * (Poles/2) < 500$

where **RPM** is a no-load speed of the motor at nominal voltage, and **Poles** is the number of rotor poles. Get these from the motor's datasheet.

If the output of the formula is more than the specified value, then the motor is not likely to work well with the SC25 controller.

Make sure that all three rules hold when selecting a brushless motor for use with SC25 controller (!!!).



*Servo drives designed around Servosila SC-25C
brushless/brushed motor controllers*

YouTube: <http://www.youtube.com/user/servosila>

www.servosila.com/en/motion-control

www.servosila.com/en/shop