



Evaluation Kit User's Manual DuNE™ DTC PE64904

pSemi Corporation
9369 Carroll Park Drive
San Diego, CA 92121
Tel: 858-731-9400

Table of Contents

Introduction.....	3
Applications Support.....	3
Evaluation Kit Contents and Requirements.....	3
DuNE™ DTC Evaluation Board (101-0597).....	4
Calibration.....	5
Port Extension.....	8
USB Interface Board (101-0580).....	11
Connection of the USB Interface Board to the Evaluation Board.....	11
EVK Software and USB Driver Installation.....	12
EVK Testing Using the Software Graphical User Interface.....	16
Frequently Asked Questions.....	20

Introduction

The DuNE™ DTC Evaluation Kit is specifically designed for evaluating the PE64904 100 MHz – 3 GHz Digitally Tunable Capacitors (DTC). The Evaluation Kit allows the user to test the DTC in 2 commonly used configurations; 2 Port Series, and 1 Port Shunt. S-Parameters can be measured and used in the synthesis of a design utilizing the DTC. Using the hardware and software provided in the Evaluation Kit, a PC running the Windows operating system can control the DTC via a USB interface.

Applications Support

For technical inquiries regarding the evaluation kit, please visit our Global Sales and Support page by clicking the Support button at psemi.com.

Evaluation Kit Contents & Requirements

Kit Contents

The DuNE™ DTC Evaluation Kit includes all of the specific software and hardware required to evaluate the Digitally Tunable Capacitor. Included in the Evaluation Kit are:

Quantity	Description
1	DTC Evaluation Board (101-0597)
2	pSemi DTC's (Populated on the 101-0597 DTC Evaluation Board, 1 in series and 1 in shunt configuration)
1	pSemi USB-MIPI/SPI/I2C Interface Board (101-0580)
1	USB 2.0 Micro B cable

Software Requirements

The evaluation kit software will need to be installed on a computer with the following minimum requirements:

PC Compatible with Windows™ 10

Mouse

USB Port

HTML Browser with Internet Access

CAUTION: The DuNE™ DTC Evaluation Kit contains components that might be damaged by exposure to voltages in excess of the specified voltage, including voltages produced by electrostatic discharges. Handle the board in accordance with procedures for handling static-sensitive components. Avoid applying excessive voltages to the power supply terminals or signal inputs or outputs.

DuNE™ DTC Evaluation Board (101-0597)

Board Overview

The 101-0597 Evaluation Board (EVB) was designed for accurate measurement of the DTC impedance and loss.

Measurement Configurations

Two measurement configurations are available: 1 Port Shunt (J3) and 2 Port Series (J4, J5).

Calibration Standards

Three calibration standards are provided. The open (J2) and short (J1) standards (104 ps delay) are used for performing port extensions and accounting for electrical length and transmission line loss. The Thru (J9, J10) standard can be used to estimate PCB transmission line losses for scalar de-embedding of the 2 Port Series configuration (J4, J5).

Board Composition

The board consists of a 4 layer stack with 2 outer layers made of Rogers 4350B ($\epsilon_r=3.48$) and 2 inner layers of FR4 ($\epsilon_r=4.80$). The total thickness of this board is 62 mils (1.57 mm). The inner layers provide a ground plane for the transmission lines. Each transmission line is designed using a coplanar waveguide with ground plane (CPWG) model using a trace width of 32 mils (0.813 mm), gap of 15 mils (0.381 mm), and a metal thickness of 1.4 mils (0.0356 mm).

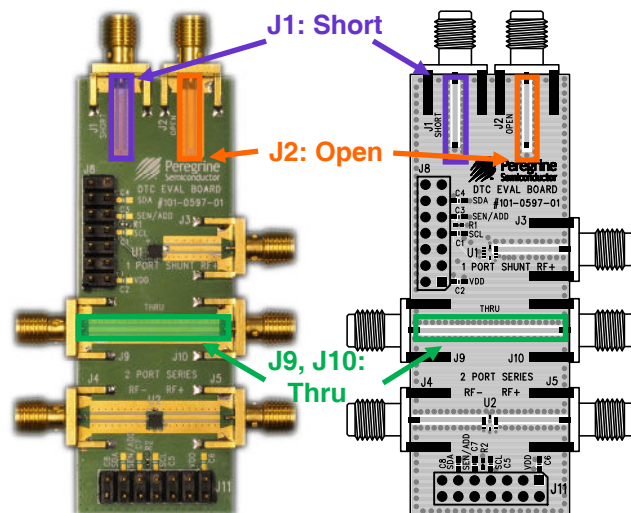
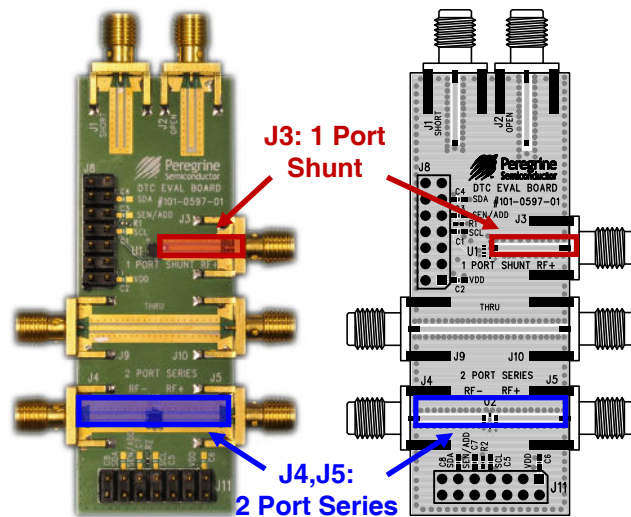

Calibration

The DTC Evaluation Board is intended to be used in conjunction with an instrument such as a PNA or a high frequency Impedance analyzer. The following steps outline the proper calibration and port extension techniques needed to take accurate measurements using the DTC Evaluation kit:

1. Ensure the frequency range of measurement is confined to the range the part is designed to operate over. (100 MHz to 3 GHz for a part such as the PE64904).
2. Ensure the PNA is equipped with high-quality phase stable cables with SMA – male connectors as the DTC Evaluation Board has SMA – female connectors.
3. Using a calibration kit such as the Agilent 85052D or Maury Microwave 8050Q, perform a full 2-Port calibration using Open, Short, Load and Thru standard. Alternately, an E-cal kit such as the Agilent 85097B can be used.

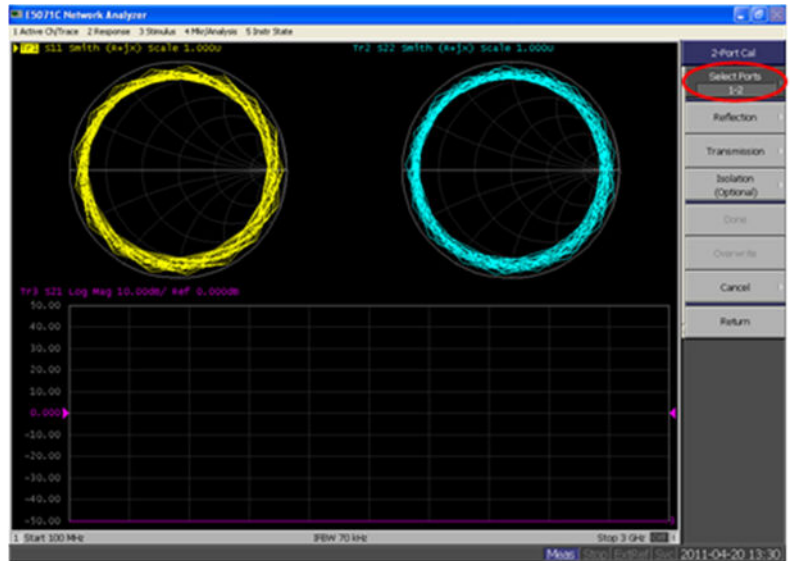

Calibration Instructions

Step 1, Calibration

Measure the Open standard on Port 1:

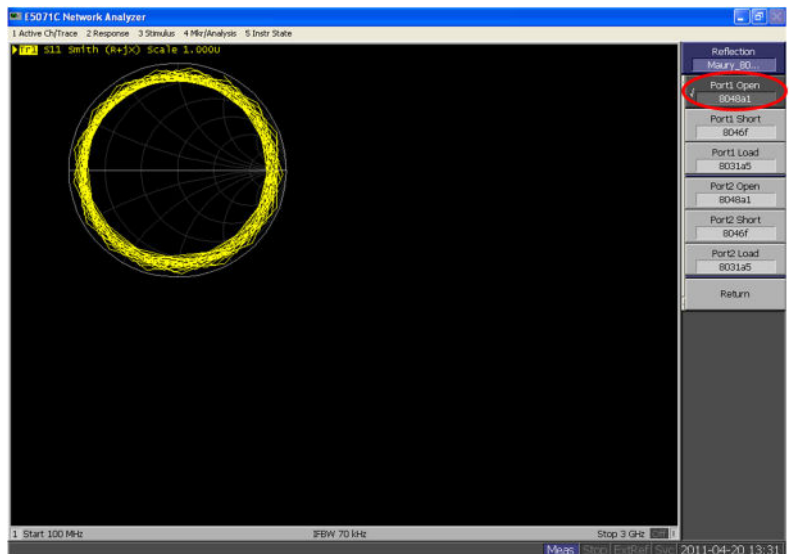

Calibration Instructions (Continued)

Step 2, Calibration

Measure the Short standard on Port 1:

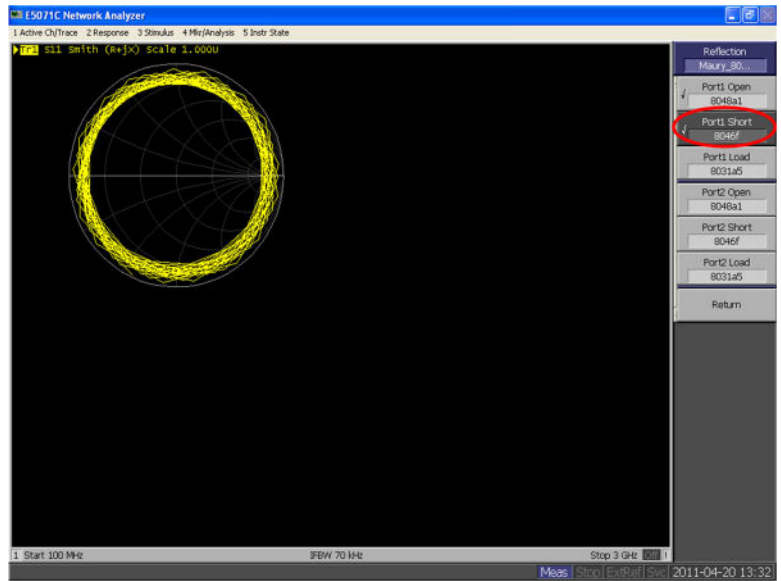

Step 3, Calibration

Measure the Load standard on Port 1:

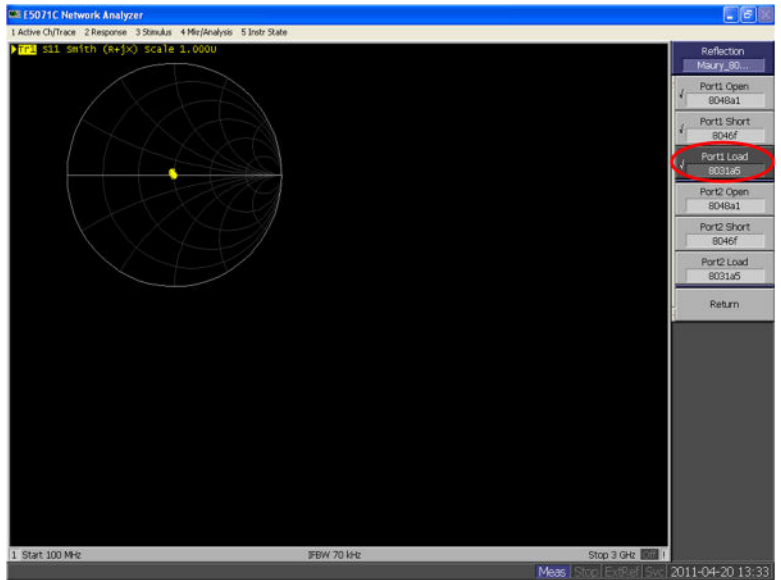

Step 4, Calibration

Repeat steps 1-3 for Port 2.

Calibration Instructions (Continued)

Step 5, Calibration

Use a calibrated thru standard to measure the Transmission properties “Port 1-2 Thru”.

If a calibrated thru standard is not available an “Unknown thru calibration” must be performed.

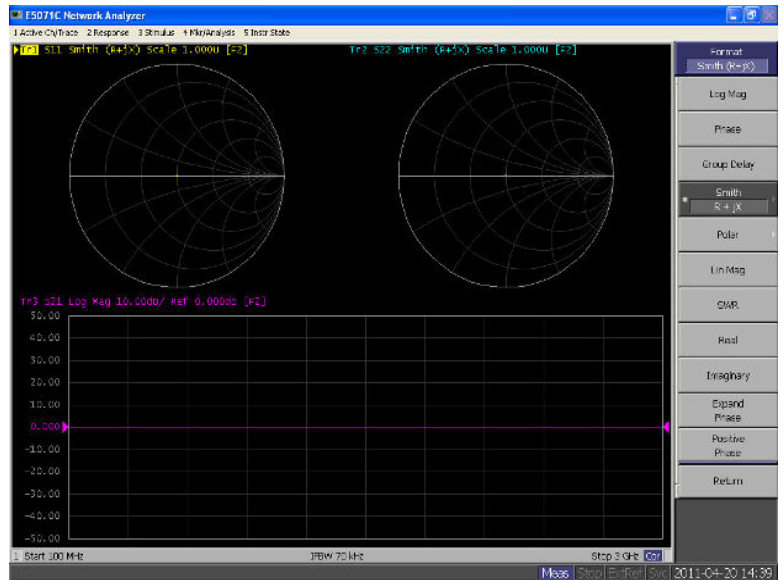
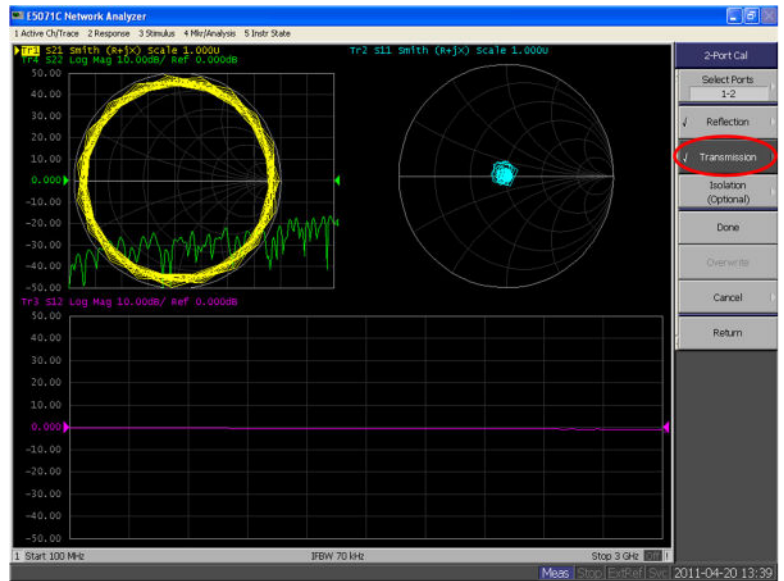

Port Extension Instructions

The J1 (Open) and J2 (Short) standards can be used to perform a port extension moving the reference plane to the input of the part being measured. Some network analyzers have an automatic port extension feature that is especially helpful. It is important that port extension be applied to both ports if 2 port measurements are to be taken.

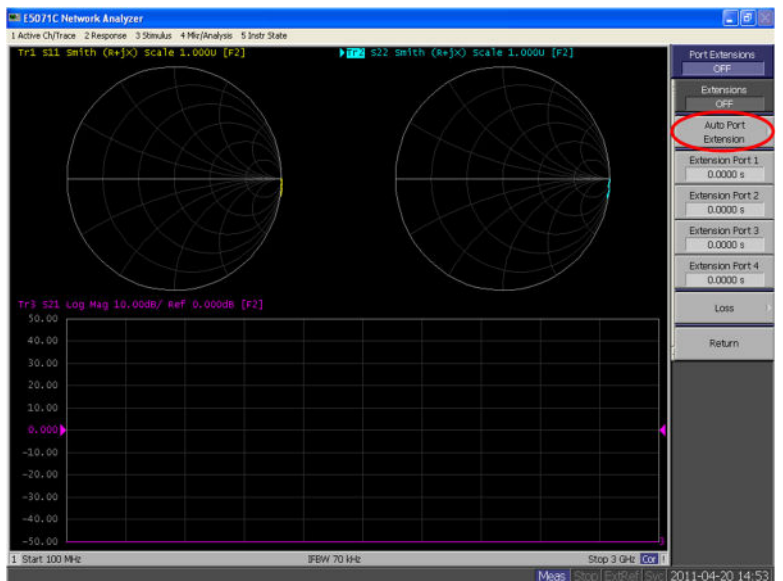
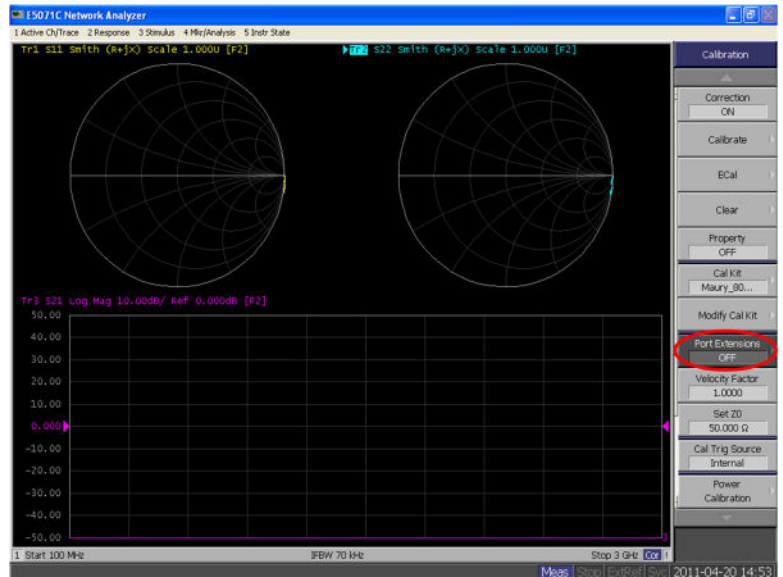
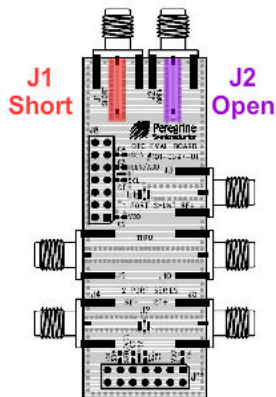

Port Extension Instructions, Continued

Step 1, Port Extension

When measuring the port extension be sure that the “Include Losses” and “Adjust Mismatch” options are set to ON.

Step 2, Port Extension

Connect and measure the Open standard on the EVK board at Port 1.

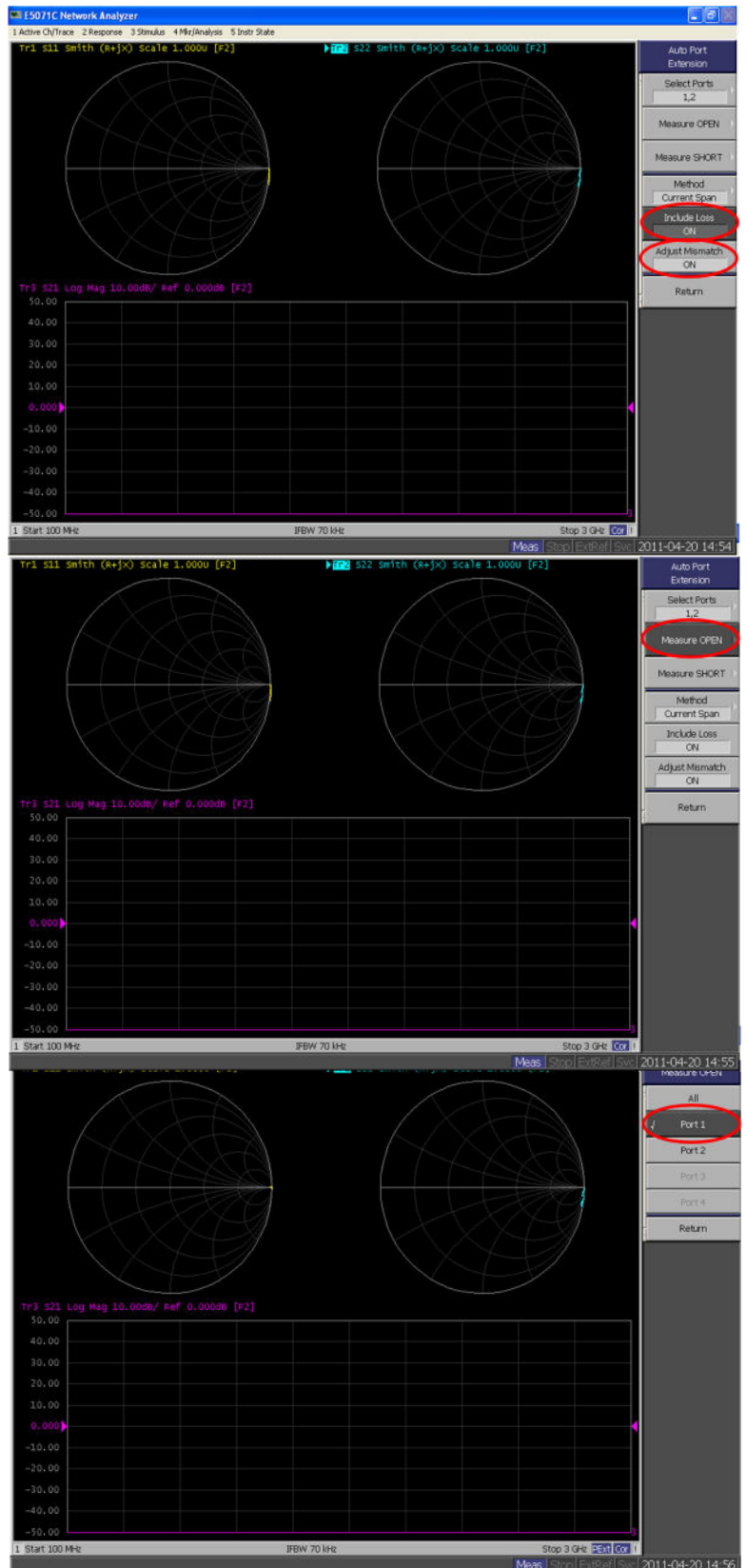

Port Extension Instructions, Continued

Step 3, Port Extension

Connect and measure the Short standard on the EVK board at Port 1.

Step 4, Port Extension

Repeat steps b and c for Port 2.

Step 5, Port Extension

After the standards are measured, the Port Extension will show approximately 103-105 ps. This value is dependent on board to board variations and may differ.

Although the transmission lines were carefully designed to be as close to 50 Ω as possible, some deviations due to manufacturing, connector placement, and temperature effects are present. Failure to port extend will yield incorrect measurements of the device.

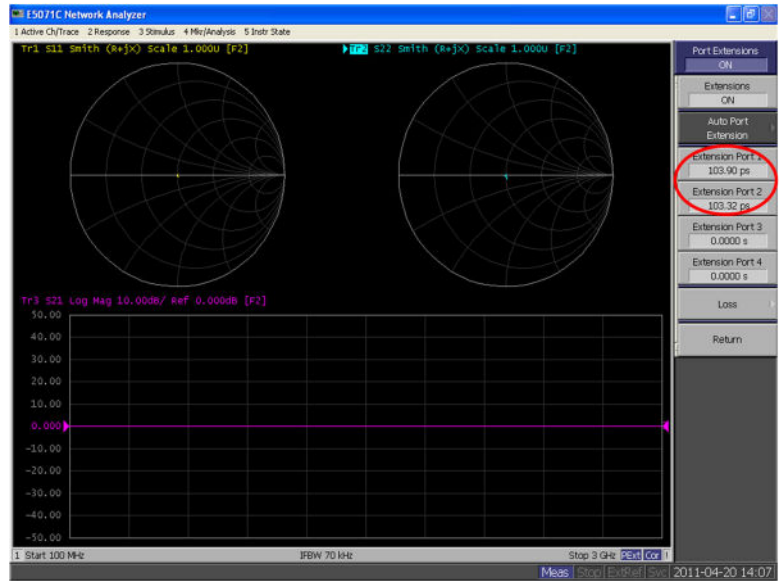

USB Interface Board (101-0580)

Board Overview

Included in the DTC evaluation kit is the USB interface board. This board allows the user to send SPI or I²C telegrams to the device under test by using a PC running the Windows™ operating system. In addition, this USB interface board provides power to the Evaluation Board. It is required to install the software drivers properly prior to evaluation. To install the drivers, extract the zip file to a temporary directory and connect the USB interface board to a spare USB port on the PC using the USB 2.0 Micro B cable. Once the board is connected, a device driver popup notification will appear on the screen.

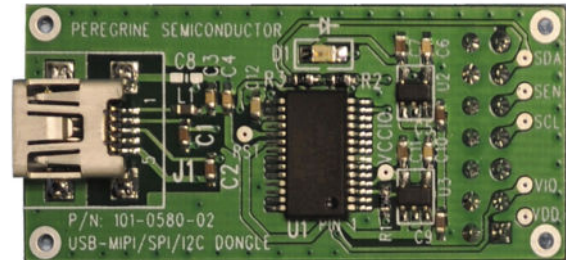

Connection of the USB Interface Board to the Evaluation Board

The Evaluation Board and the USB interface board contain a keyed 14-pin header. This feature allows the USB interface board (receptacle) to connect directly to the Evaluation Board (pin) at the test site as shown.

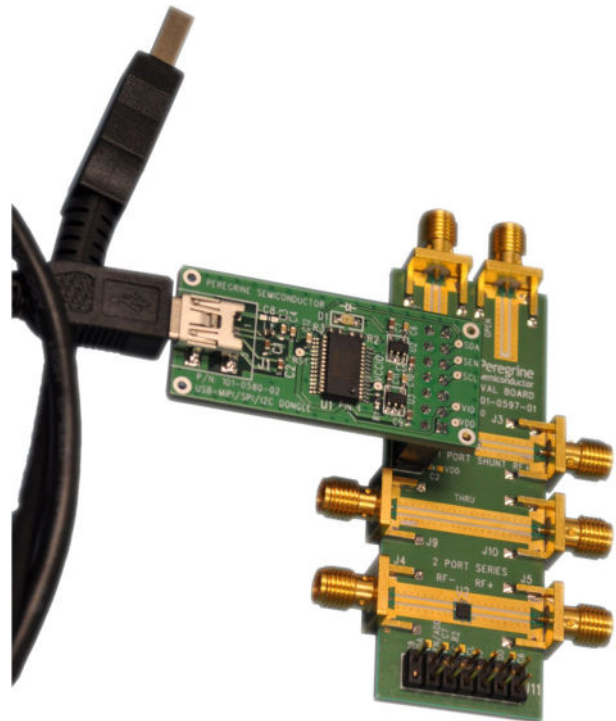

EVK Software and USB Driver Installation

Because the device drivers are located at a specific location and it is not required that Windows™ search from them, select the “Install from a list or specific location (Advanced)” and click “Next >.” The driver installation and notification dialog boxes may differ depending on which version of Windows™ is installed on the PC.

Select “Don’t search. I will choose the driver to install” and click “Next >”

Select “Universal Serial Bus controllers” and click “Next >”

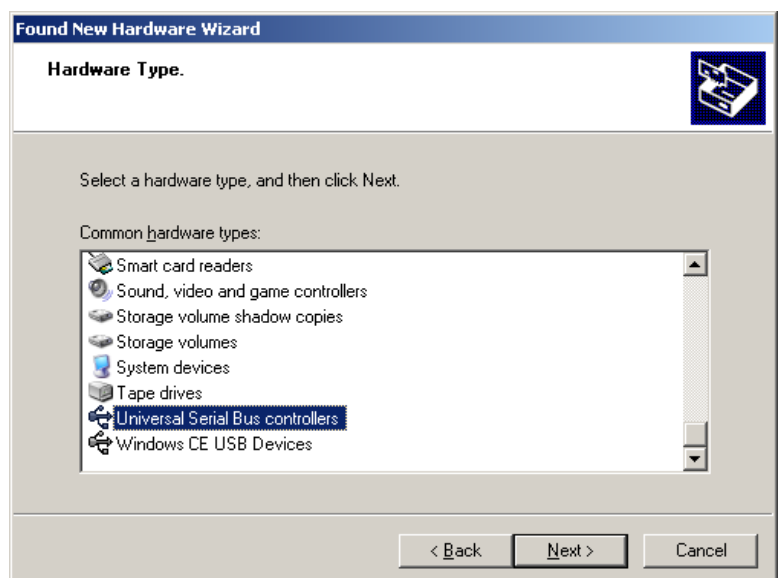
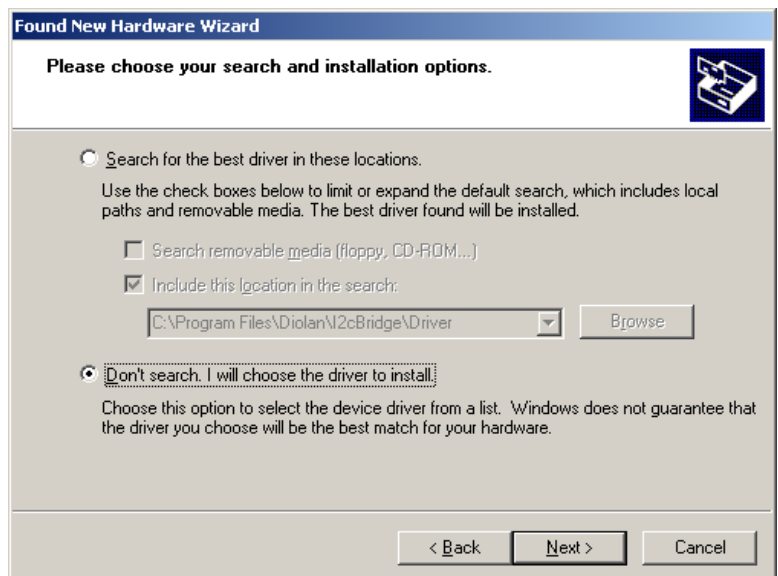

EVK Software and USB Driver

Click the “Have Disk...” button.

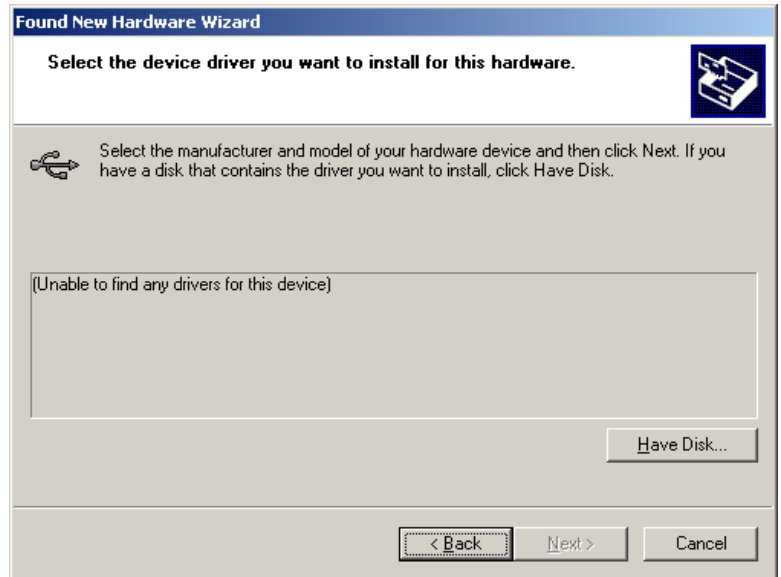

Browse to the location to which the driver files were extracted. This is likely C:\TEMP

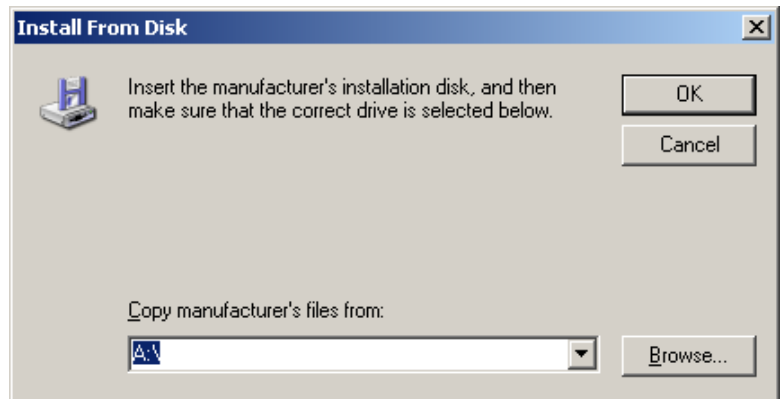

Click “ftdibus.inf” and click Open, then select “Next >”

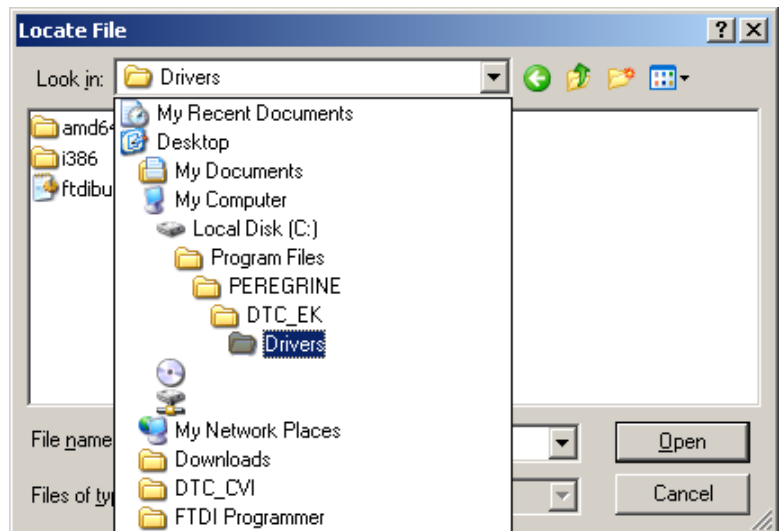

EVK Software and USB Driver Installation, Continued

Ignore the warnings and continue until the driver is installed. Because this driver is not digitally signed with Microsoft, several warnings may appear. These warnings can be ignored; select the options to proceed with driver installation.

Once the USB drivers are installed, the DuNE™ DTC Evaluation Kit Software can be installed. The USB device drivers and DuNE™ DTC Evaluation Kit Software is compatible with computers running Windows™ 10. This software is available directly from pSemi. To install this software simply unzip the archive and execute the “setup.exe.”

After the setup.exe file has been executed, a welcome screen will appear. It is strongly recommended that all programs be closed prior to running the install program. Click the “Next >>” button to continue the software installation.

For most users, the default installation location for the program files is sufficient. If a different location is desired, the installation program can be directed to place the program files in an alternate location. Once the desired location is selected click the “Next >>” button to proceed.

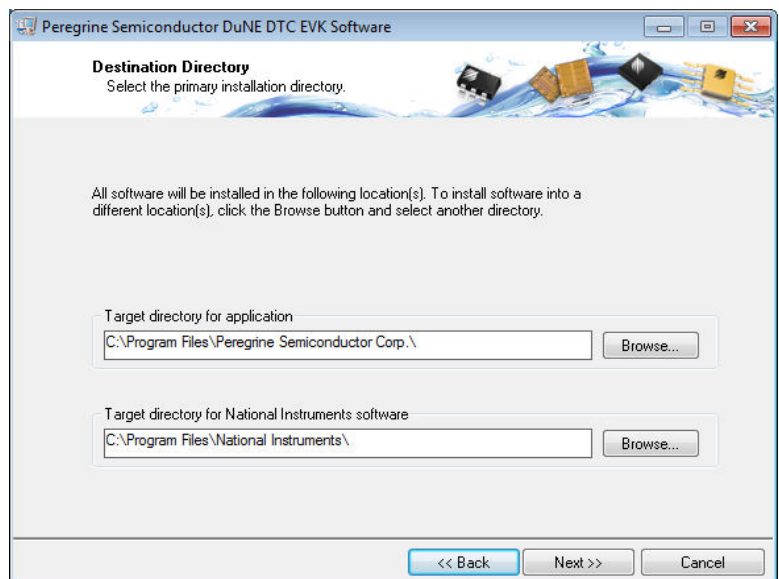
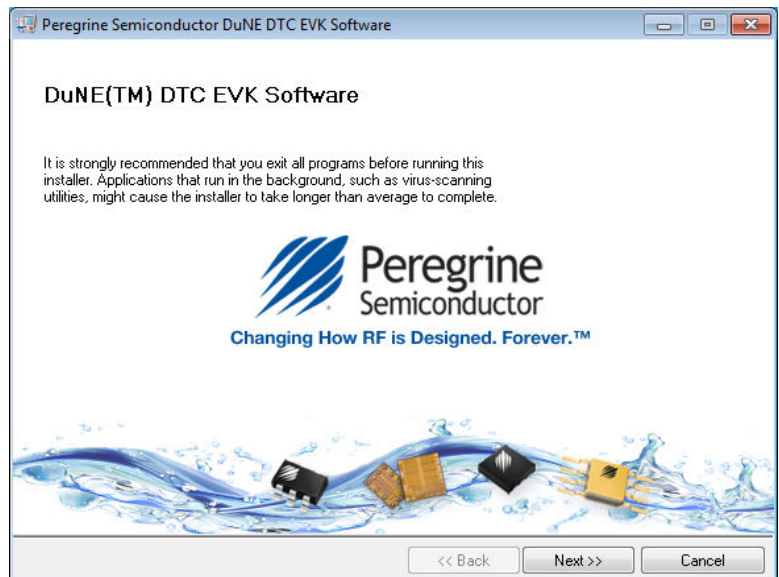
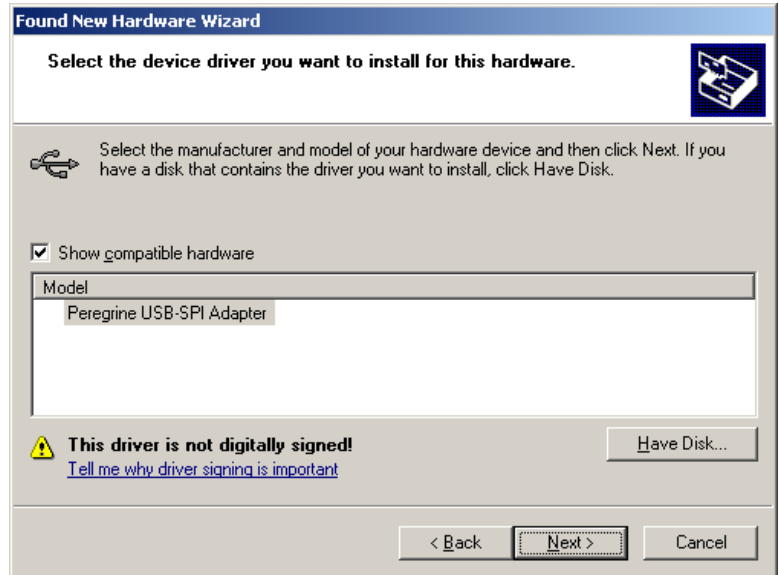

EVK Software and USB Driver Installation, Continued

The third installation screen shows a summary of actions the install application will perform. If the DuNE™ DTC EVK software is already installed, the installer will update the files to the newest version.

As the software files are installed, a progress indicator is displayed. On slower computers, installation of the software may proceed for a few moments.

Once the program is installed a new Start Menu item under “Peregrine Semiconductor” will appear.

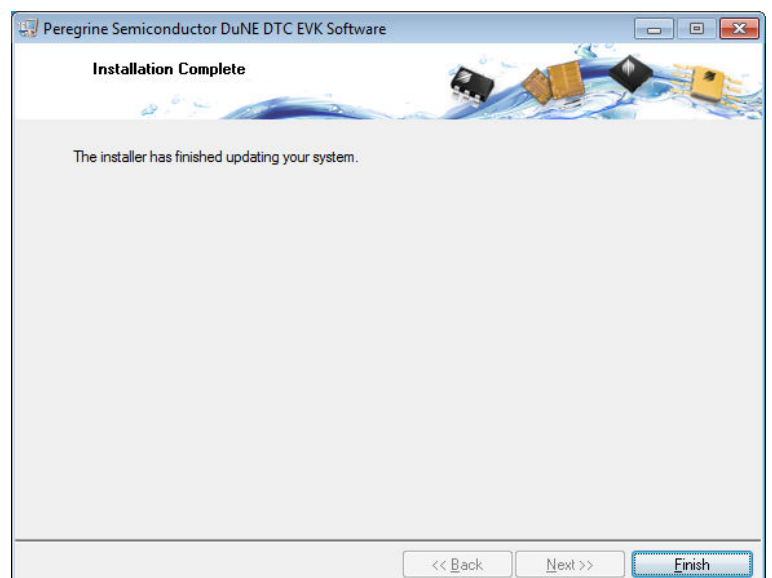
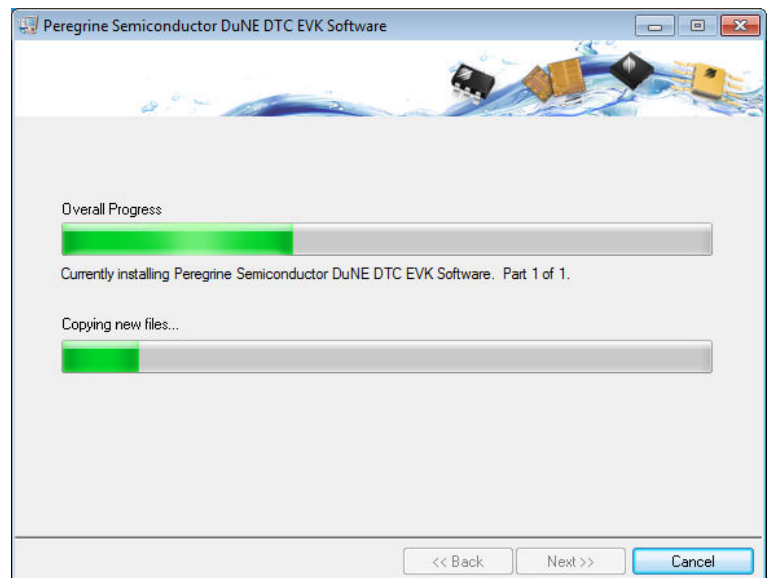
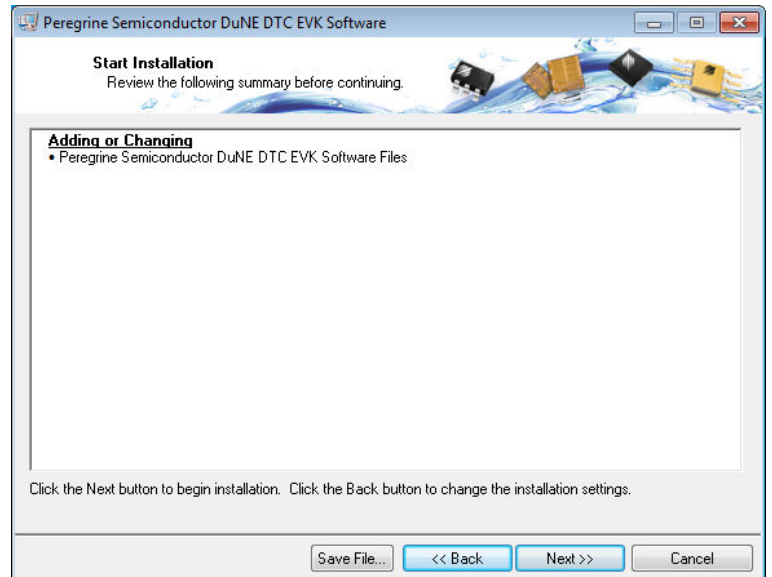

EVK Testing using the Software Graphical User Interface

Ensure the USB Interface is plugged into the computer and launch the software. Upon execution, the main DTC control screen will be displayed.

Step 1, EVK Testing

In the upper left corner under the Peregrine Logo there is a drop down menu item to select the part for evaluation. This is an important drop down item as it determines which serial peripheral interface and telegram structure the program will send to the parts under test. It is important to select the part being evaluated. Selecting the wrong part number may result in sending improper commands to the DTC under test, yielding unpredictable test results.

Step 2, EVK Testing

Once the Part Number to test has been selected, the information box will populate with specs on that part, including the shunt capacitance values and tuning ratio. The Shunt capacitance and tuning ratio values refer to the parts performance at the lowest frequency of operation specified for the part. If the USB drivers were installed properly, a default telegram instructing the DTC to change to state 15 will be issued. The “Last Serial Interface Signal” will display the telegram last sent from the USB interface board to the evaluation board.

- If the DTC under test received the telegram successfully, a change in impedance will be observed on the Network Analyzer or Impedance Analyzer.
- If the USB interface board is not connected, or the drivers are installed incorrectly, the “Last Serial Interface Signal” display will be blank and the message “**The USB interface board is not connected. Please connect it and restart the program.**” will appear at the

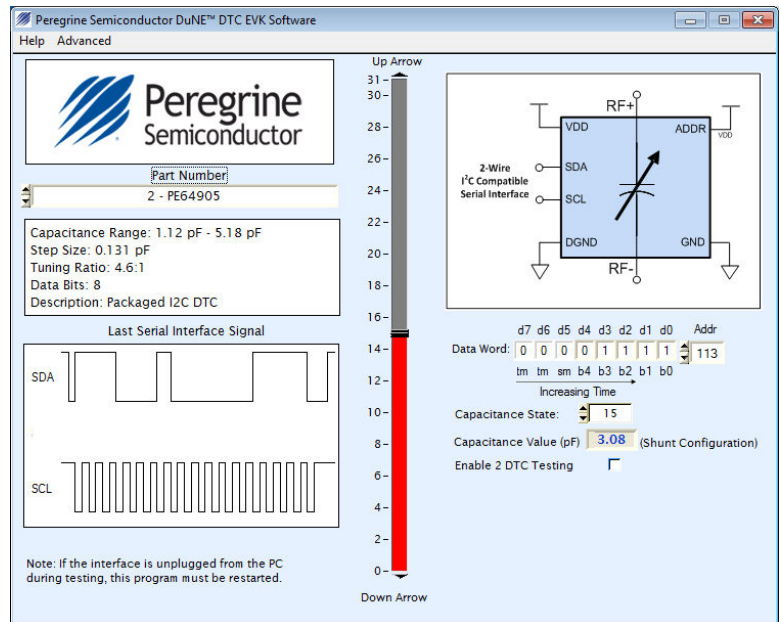
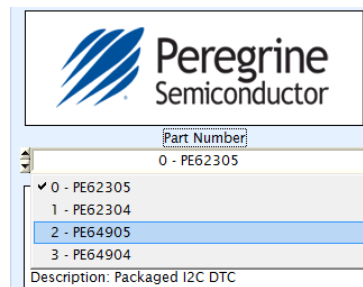
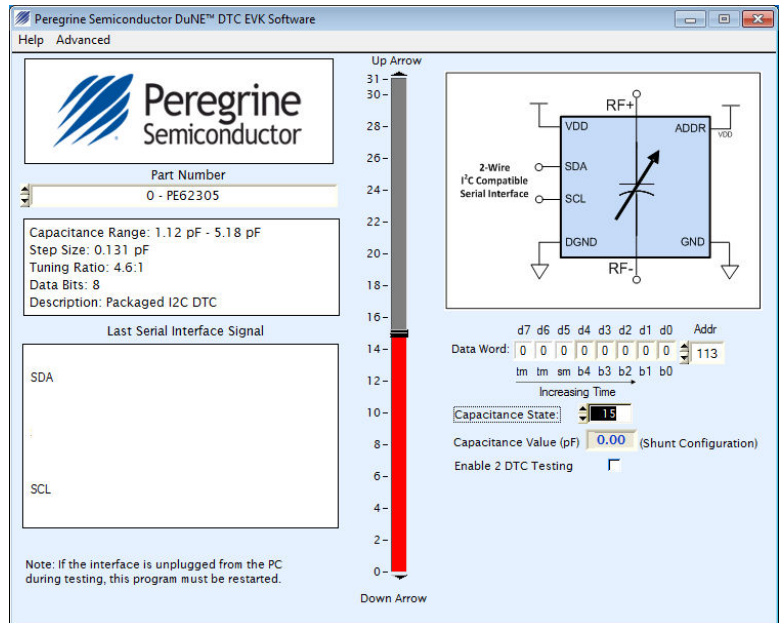

EVK Testing using the Software Graphical User Interface, Continued

Step 3, EVK Testing

If the USB interface board is connected properly, the software can use it to send programming telegrams to the device under test. By using the slider the DTC can be set to different tuning states.

- a. By connecting port 1 of the VNA to J3, a 1 port shunt measurement can be taken. In the example shown here a 1 Port Shunt measurement of the DTC is performed at tuning State 0.

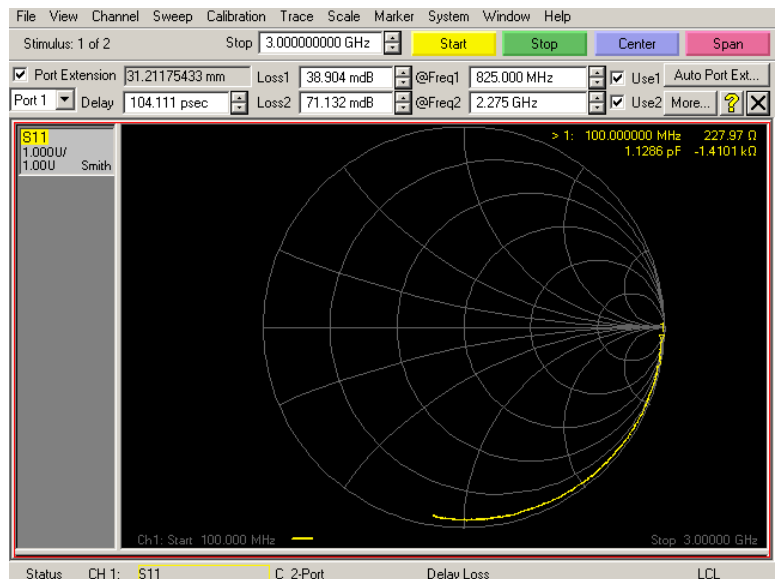
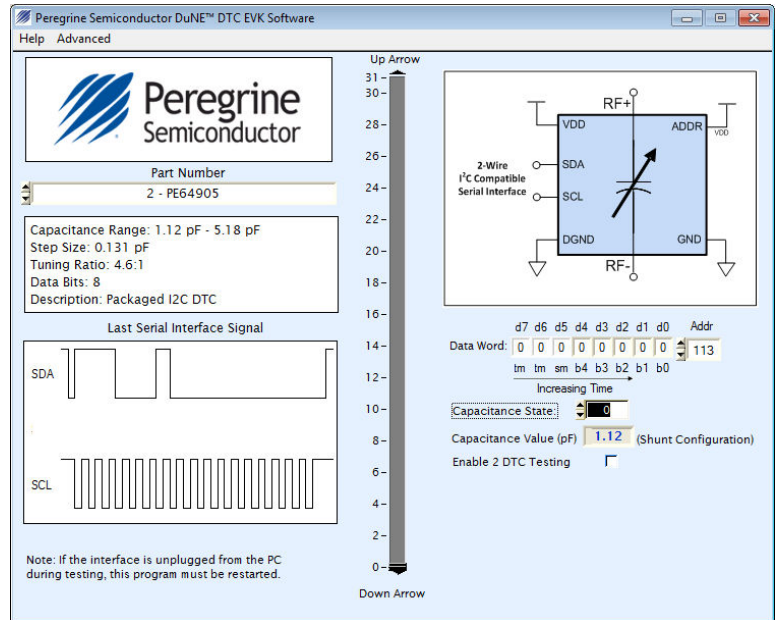

EVK Testing using the Software Graphical User Interface, Continued

Step 5, EVK Testing

The DuNE™ Evaluation Kit Software can be used to circuits that utilize DTCs in the following configurations:

- a. 1 - I²C-compatible DTC configured for address 112 or 113
- b. 1 - SPI-compatible DTC
- c. 2 - I²C-compatible DTCs (1 DTC on address 112, 1 DTC on address 113.) This configuration of 2 DTC's is not available on the Evaluation Kit, but may be useful for the

- d. To enable 2 DTC testing, click “Enable 2 DTC Testing.”

A separate slider will appear, allowing control of a second DTC. The leftmost slider controls the DTC on address 112, while the right controls the DTC on address 113. The SDA and SCL pins from the USB interface board must be connected to the circuit for

Step 6, EVK Testing

The USB Interface board cannot be unplugged while the EVK software is running. If it is, the program must be closed and restarted for the USB interface board to function. No error message will be present if the USB interface

Step 7, EVK Testing

To check the version of the software being used for evaluation, select the “Help-About”

Step 8, EVK Testing

There is an option in the program to change the delay between each clock pulse of the digital telegram. This delay should never be set below 0.01 seconds; doing so may give unpredictable results. Access to this option can be toggled under the “Advanced” menu.

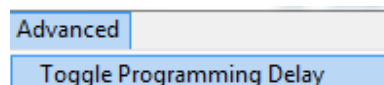
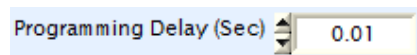
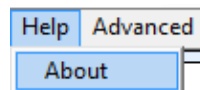
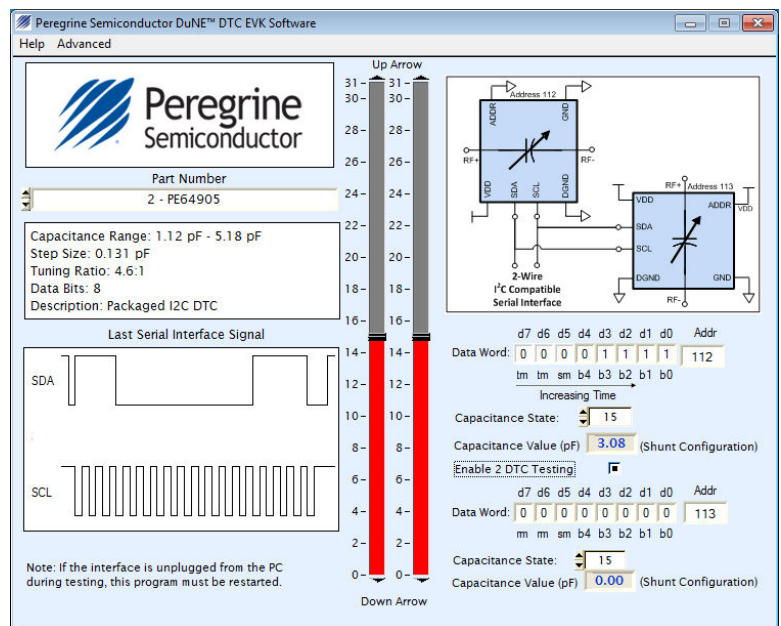

Frequently Asked Questions

1. The message “**The USB interface board is not connected. Please connect it and restart the program.**” is present when I try to set different tuning states and it appears the device is not programming.

Ensure the USB interface drivers are installed properly. Close and restart the EVK software.

2. No error messages are displayed in the EVK software, but the device under test does not appear to change capacitance value.

Ensure the correct part number is selected. Ensure the USB interface board is connected to the Evaluation Board at the correct test site and orientation.

3. The capacitance values measured using the network analyzer are offset, or differ, from the values shown in the program.

Ensure the values compared refer to the correct test configuration (1 port shunt etc.) Ensure port extension has been performed properly. If the port extension isn't included in the measurement, capacitance values will typically measure much higher than expected.

4. The Q values measured do not match what's shown in the datasheet for the part number I am testing.

Q is a measurement very sensitive to proper de-embedding of transmission line effects. Since each Evaluation Board has small variances in contact resistance and transmission line length, it cannot be relied upon for accurate Q measurements. pSemi uses a specially designed test fixture and measurement instrument to perform Q measurements.

Sales Contact and Information

For sales and contact information please visit www.psemi.com.

Advance Information: The product is in a formative or design stage. The datasheet contains design target specifications for product development. Specifications and features may change in any manner without notice.

Preliminary Specification: The datasheet contains preliminary data. Additional data may be added at a later date. pSemi reserves the right to change specifications at any time without notice in order to supply the best possible product. **Product Specification:** The datasheet contains final data. In the event pSemi decides to change the specifications, pSemi will notify customers of the intended changes by issuing a CNF (Customer Notification Form).

The information in this document is believed to be reliable. However, pSemi assumes no liability for the use of this information. Use shall be entirely at the user's own risk.

No patent rights or licenses to any circuits described in this document are implied or granted to any third party. pSemi's products are not designed or intended for use in devices or systems intended for surgical implant, or in other applications intended to support or sustain life, or in any application in which the failure of the pSemi product could create a situation in which personal injury or death might occur. pSemi assumes no liability for damages, including consequential or incidental damages, arising out of the use of its products in such applications.

The Peregrine Semiconductor name, Peregrine Semiconductor logo and UltraCMOS are registered trademarks and the pSemi name, pSemi logo, HaRP and DuNE are trademarks of pSemi Corporation in the U.S. and other countries.

pSemi products are protected under one or more of the following U.S. patents: patents.psemi.com.