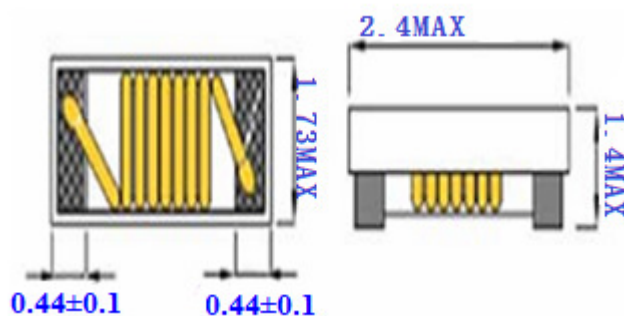
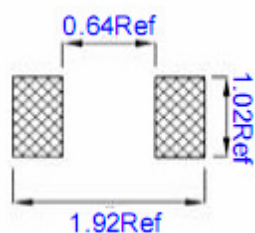

SHAPE & DIMENSION (UNIT:mm)

PAD LAYOUT(MM):

ELECTRICAL SPECIFICATION

MEAS. ITEM	SPEC.				TEST FREQ.	CONDITIONS
L	15	μH	±	10%	2.5MHz/0.1V	Ta=25°C , I_{dc}=0A
DCR	1.4	Ω	±	30%		Ta=25°C
I_{sat}	0.3A_{MAX}(0.34A_{TYP})				2.5MHz/0.1V	ΔL/L ≤ 30%
I_{rms}	0.38A_{MAX}(0.48A_{TYP})				2.5MHz/0.1V	ΔT ≤ 40°C

GENERAL SPECIFICATION

Electrical specifications :	at 25°C
Operation Temperature:	-40~+125°C
Storage Temperature:	-40~+125°C

(1)WIRE TYPE: \varnothing 0.05mm

(2)WINDING:50.5Ts(Ref.)

Isat(飽和電流):電感瞬間的突波電流

TME(秒)	Lsat(A)	L(UH)	$\Delta L/L(\%)$
1	0.000	15.80	0.00%
1	0.04	15.80	0.00%
1	0.08	15.80	0.00%
1	0.12	15.80	0.00%
1	0.16	15.80	0.00%
1	0.20	15.70	-0.63%
1	0.24	15.40	-2.53%
1	0.28	14.90	-5.70%
1	0.32	13.90	-12.03%
1	0.36	12.30	-22.15%
1	0.40	8.94	-43.42%

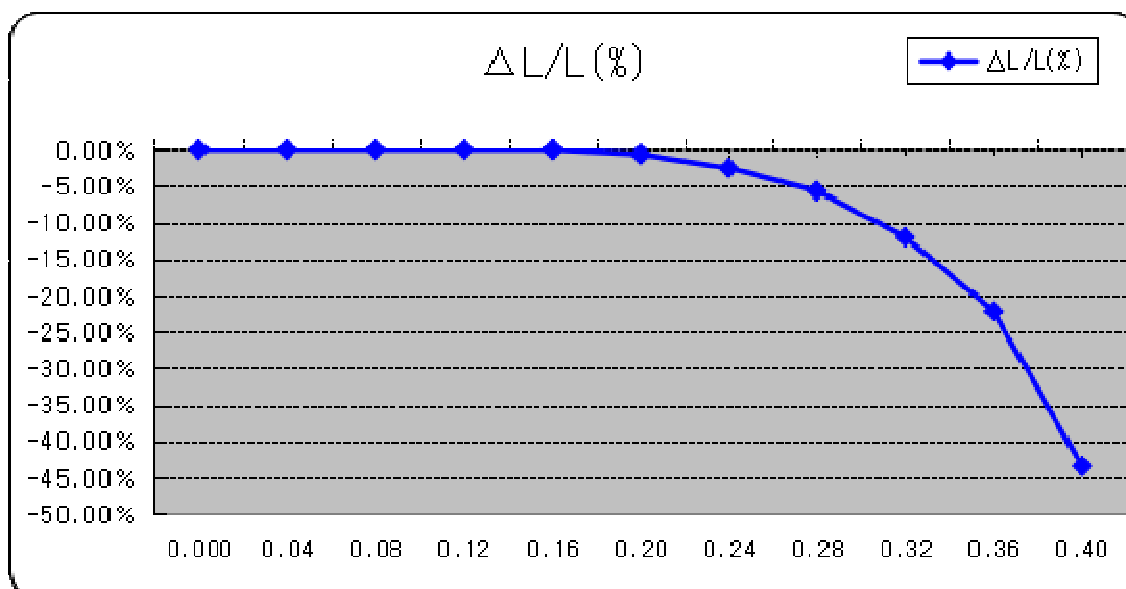

單點溫昇

TIME(S)	Irms(A)	L(uH)	$\Delta L/L(\%)$	Temp($^{\circ}\text{C}$)	$\Delta T(^{\circ}\text{C})$
30	0.000	15.60	0.00%	30.0	0.0
30	0.049	15.60	0.00%	30.0	0.0
30	0.098	15.60	0.00%	31.0	1.0
30	0.147	15.50	-0.64%	32.0	2.0
30	0.196	15.30	-1.92%	34.0	4.0
30	0.245	14.90	-4.49%	38.0	8.0
30	0.294	14.20	-8.97%	42.0	12.0
30	0.343	12.50	-19.87%	48.0	18.0
30	0.392	8.76	-43.85%	55.0	25.0
30	0.441	4.26	-72.69%	64.0	34.0
30	0.490	2.86	-81.67%	77.0	47.0

※DC bias current characteristics in the ambient temperature 25 $^{\circ}\text{C}$ Frequency 2.5MHz/0.1V

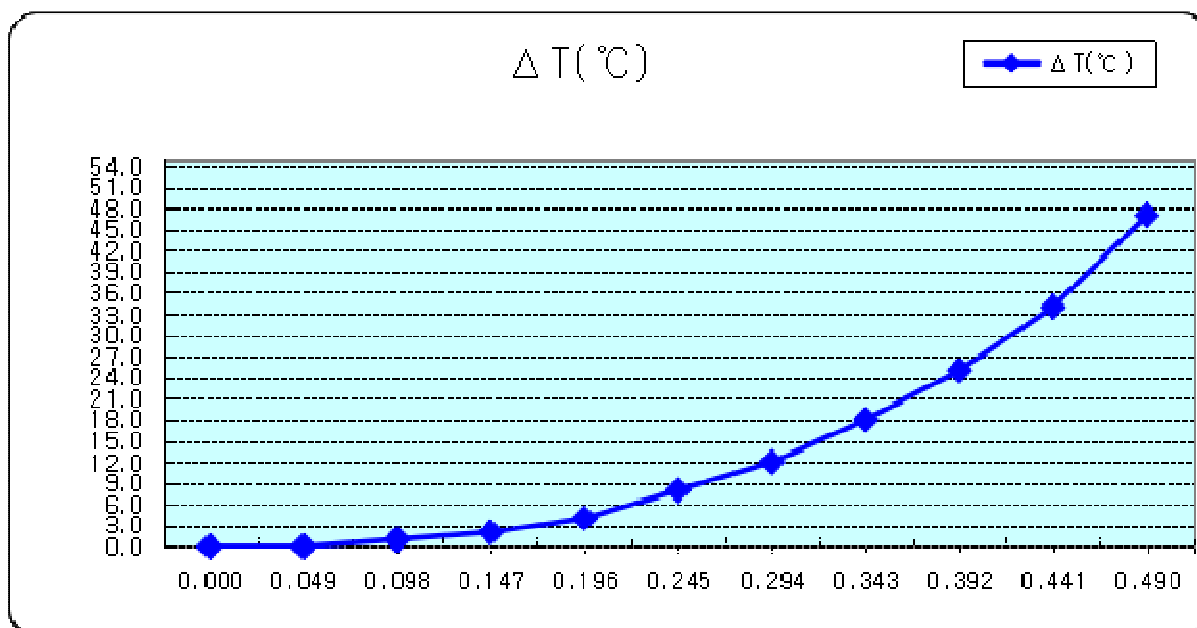

TEST DATA FOR PREPRODUCTION SAMPLE

TEST RESOLUTION					DIMENSION (Unit: mm)		
MEAS.	L	D.C.R			长	宽	高
ITEM	μH	Ω			mm	mm	mm
SPEC.	15	1.4			Max.2.4	Max.1.73	1.3±0.1
	±	±					
	10%	30%					
TEST FREQ.	2.5MHz/0.1V		Isat 0.3A	$\Delta L/L \leq 30\%$			
1	15.4	1.57	14.2	-7.8%	2.21	1.44	1.17
2	15.2	1.58	14.1	-7.2%	2.19	1.48	1.16
3	16.0	1.52	14.6	-8.8%	2.15	1.45	1.31
4	15.3	1.52	14.5	-5.2%	2.24	1.64	1.29
5	15.4	1.59	13.9	-9.7%	2.28	1.62	1.24
6	15.7	1.54	14.5	-7.6%			
7	15.8	1.52	13.7	-13.3%			
8	15.2	1.59	14.2	-6.6%			
9	16.2	1.56	14.6	-9.9%			
10	15.4	1.58	14.2	-7.8%			
AVG.	15.560	1.6	14.250	-8.39%			
R	1	0.07	1.60	-4.20%			

PACKAGING

热封包装

Reel dimensions

UNIT : mm

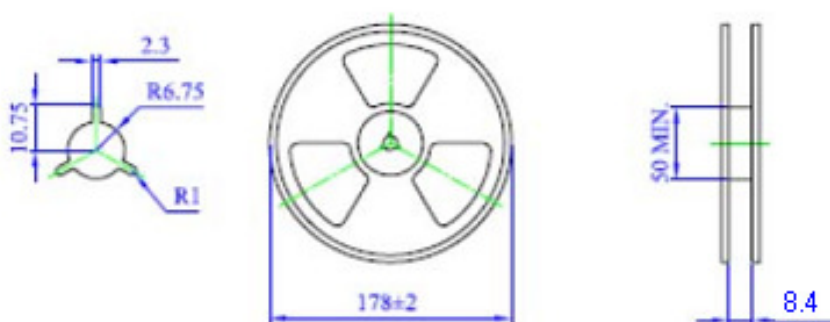

Tape dimensions

UNIT : mm
TOLERANCE : ±0.1

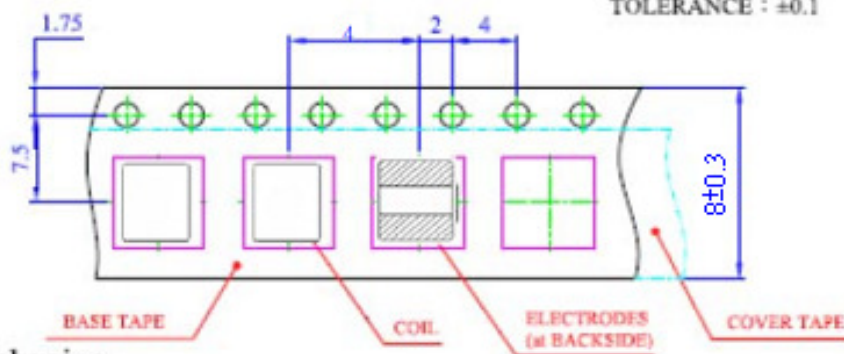

Packaging

Quantity : **2000** pcs/reel