

AMP AMP Connect

Alphabetical Picture Part Number
SEARCH SEARCH SEARCH

Go To Step Search™ Screen

MAIN MENU HELP
FAMILIES REGISTRATION

66740-6 -- 1 of 1 products

**Multimate Contacts
Multimate**

- General **INFO**
- Sales **INFO**
- Customer Drawings **SPECIFICATIONS**

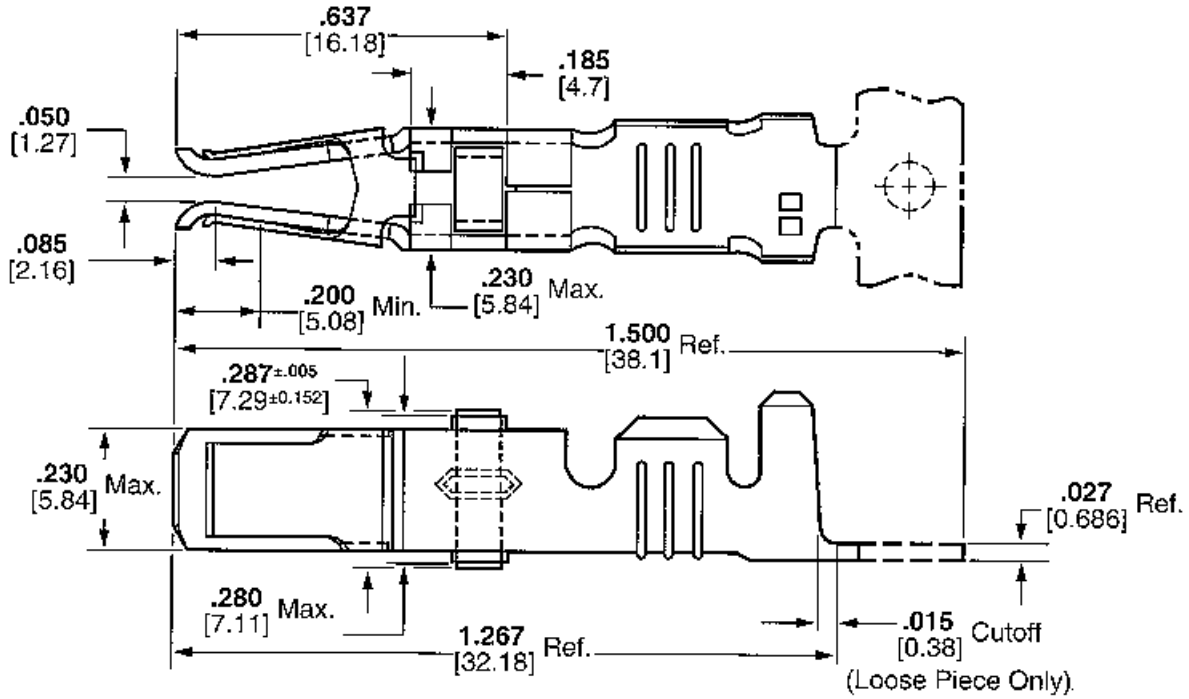

Female

Line art represents typical product only.

Searchable Features:

Pin/Socket	Socket
Contact Mating Area Plating	Gold (30)
Packaging Method	Loose Piece
Wire Range	14-12 [2.0-3.0 ²] AWG [mm], 16 [1.25-1.40 ²] AWG [mm]
Insulation Diameter Range	.135-.160 [3.43-4.06] in. [mm]
Contact Material	Copper
Termination End Plating	Gold (30)
Product Type	Type XII
Contact Size	Power Contact
Contact Type	Power
Terminate To	Wire
Insulation Support	Yes
Wire Termination Type	Crimp

Other Properties:

Wire/Cable Type	Discrete Wire
Test Current	35 amperes
Grade	Commercial
CERTI-CRIMP Hand Tool	69710-1
Used With	G Series Connectors, M Series Connectors
Die Insert	90145-1, 90145-2
Extraction Tool	91019-3
Comment	Hand Tool No. 69710-1 uses Die Insert No. 90145-2 for 16 AWG and Die Insert No. 90145-1 for 14-12 AWG wire.