

Anti Surge SMD Resistor

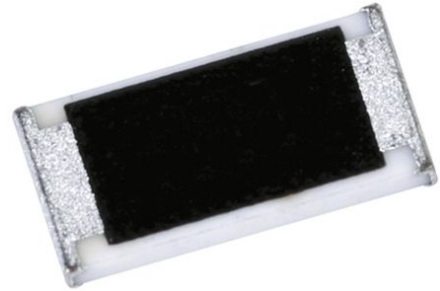

Features

- Small size and light weight
- High-Precision, high-power, anti-pulse
- Suitable for both wave and reflow soldering
- ESD surge characteristics superior to standard metal film resistors
- RoHS compliant



Application

AV adapter, LCD back-light, camera flash, etc

PART NUMBER

Example: RND 155AS03W4J0100T5E

RND 155AS03	W4	M	0100	T	5	E
Type	Wattage	Tolerance	Resistance Value	Packing Type	Packing Quantity	Special Feature
RND 155AS03: 0603 RND 155AS05: 0805 RND 155AS06: 1206	Normal size: W2=1/2W W3=1/3W W4=1/4W W5=1/5W 34=3/4W WJ=1.5W Small size: S4 = 1/4W-S S2 = 1/2W-S 06 = 0.6W-S 07 = 3/4W-S	J ~ ± 5% K ~ ± 10% M ~ ± 20%	E24 series: the 1st digit is "0" the 2nd & 3rd digits are for the significant figures of the resistance and the 4th indicate the number of zeros following: E96 series: the 1st to 3rd digits are for the significant figures of the resistance and the 4th digit indicate the number of zeros following: Decimal point is expressed: "J"~ 0.1, "K"~0.01, "L"~0.001	T=T/R Packing	4=4000 pcs 5=5000 pcs	E= Lead(pb) Free Plating Type / RoHS compliant

Scope:

This specification for approval relates to Anti- Surge Thick Film Chip Resistors (Lead Free) manufactured by RND. Application automobile. The test items follow the test standard of AEC-Q200.

Ratings:

Type	RND 155AS03	RND 155AS05	RND 155AS06
Power Rating	1/4W	1/2W	0.6W
Max. Working Voltage	50 V	150 V	200 V
Max. Overload Voltage	100 V	300 V	400 V
Dielectric Withstanding Voltage	300 V	500 V	500 V
Temperature Range	-55°C ~ +155°C		
Ambient Temperature	70 °C		

Anti Surge SMD Resistor



Power rating

Resistors shall have a power rating based on continuous load operation at an ambient temperature of 70 °C .
For temperature in excess of 70 °C , The load shall be derate as shown in figure 1.

Figure 1

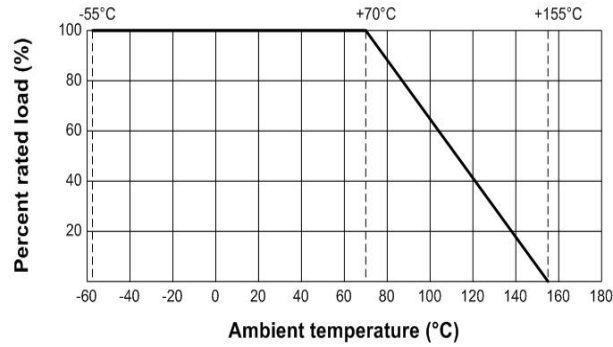

One-pulse Limiting Electric Power:

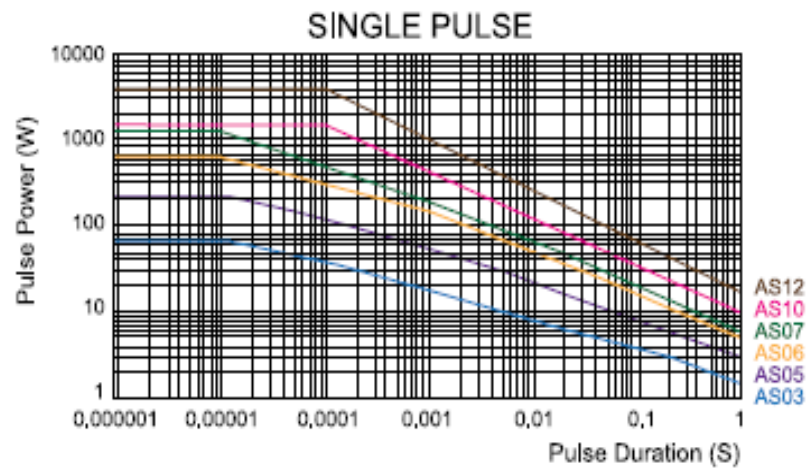

Nominal Resistance

Effective figures of nominal resistance shall be in accordance with E-24 series E-24 series for 5%, 10%, 20%

Lightning Surge

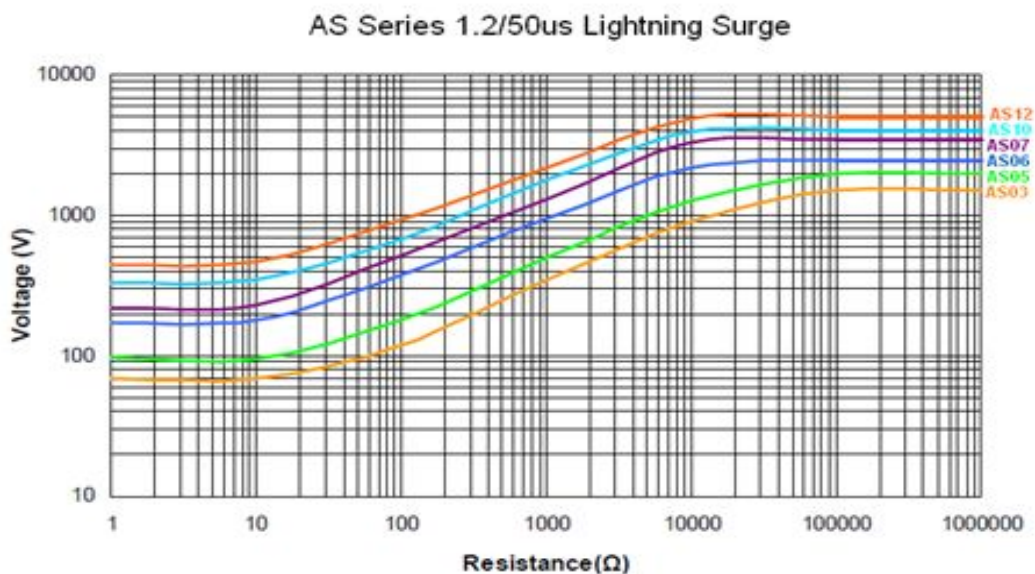

Anti Surge SMD Resistor

Construction

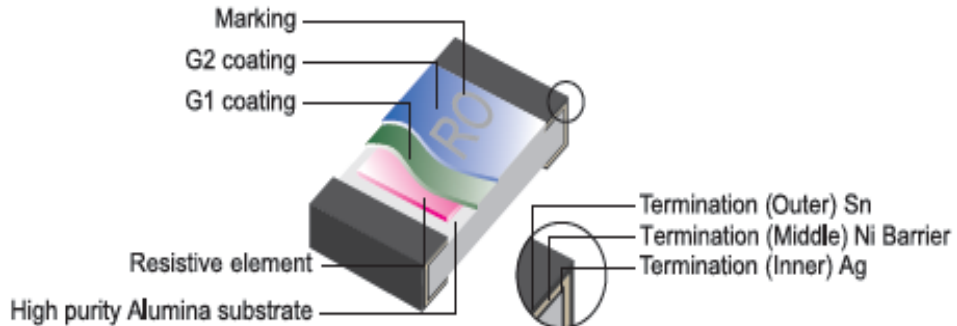

Power rating and dimensions

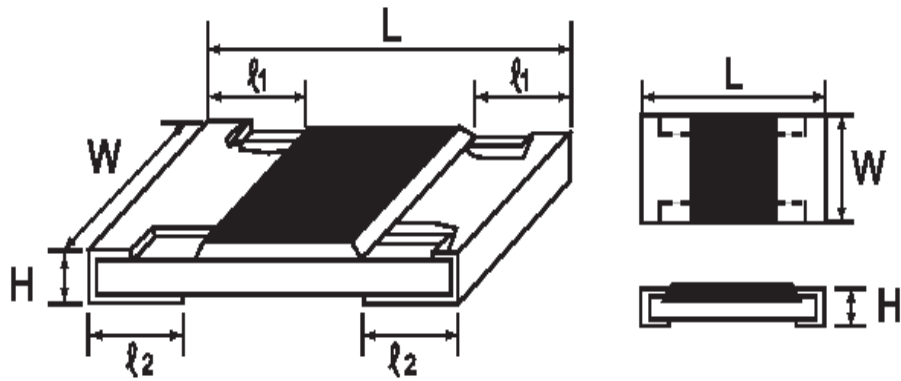

Type	Dimension (mm)				
	L	W	H	l1	l2
RND 155AS03	1.60 ± 0.10	0.80 ± 0.10	0.45 ± 0.10	0.30 ± 0.20	0.30 ± 0.20
RND 155AS05	2.00 ± 0.15	1.25 + 0.15 - 0.10	0.55 ± 0.10	0.40 ± 0.20	0.40 ± 0.20
RND 155AS06	3.10 ± 0.15	1.55 + 0.15 - 0.10	0.55 ± 0.10	0.45 ± 0.20	0.45 ± 0.20

Power Rating :

Type	Power Rating at 70 °C	Tolerance %	Resistance Range	Standard Series
RND 155AS03	1/4W		1Ω ~ 10MΩ	E-24
RND 155AS05	1/2W	±5% ±10% ±20%	1Ω ~ 10MΩ	E-24
RND 155AS06	0.6W		1Ω ~ 10MΩ	E-24

Anti Surge SMD Resistor

Marking

A. Marking for E-24 series in RND 155AS03, RND 155AS05, RND 155AS06 size : 3 Digits

*The first two digits are significant figures of resistance and the third digit denoted number of zeros

Ex.

	333		33K Ω
--	-----	--	--------------

*For ohmic values below 10 Ω , letter "R" is for decimal point.

Ex.

	2R2		2.2 Ω
--	-----	--	--------------

Anti Surge SMD Resistor



Performance specification :

Characteristics	Limits	Test Methods (JIS C 5201-1)
Dielectric withstanding voltage	No evidence of flashover mechanical damage, arcing or insulation break down	4.7 Clamped in the trough of a 90°C metallic v-block and shall be tested at ac potential respectively specified in the type for 60-70 seconds
Temperature Coefficient	1Ω~10Ω : ± 400 PPM/°C 10.1Ω~10MΩ : ± 100 PPM/°C	4.8 Natural resistance change per temp. degree centigrade. $\frac{R2-R1}{R1(t2-t1)} \times 10^6 \quad (\text{PPM/ } ^\circ\text{C})$ R1: Resistance value at room temperature (T1) R2: Resistance value at room temp. plus 100 °C(T2) Test pattern: room temp. (T1), room temp. +100°C(T2)
Short time overload	Resistance change rate is ± (1.0% + 0.1Ω) Max.	4.13 Permanent resistance change after the application of a potential of 2.5 times RCWV for 5 seconds
Soldering temp. reference	Electrical characteristics shall be satisfied. Without distinct deformation in appearance. (95 % coverage Min.)	<p>Wave soldering condition: (2 cycles Max.) Pre-heat : 100 ~ 120 °C, 30 ± 5 sec. Suggestion solder temp.: 235 ~ 255 °C, 10 sec. (Max.) Peak temp.: 260 °C</p> <p>Reflow soldering condition: (2 cycles Max.) Pre-heat : 150 ~ 180 °C, 90 ~ 120 sec. Suggestion solder temp.: 235 ~ 255 °C, 20 ~ 40 sec. Peak temp.: 260 °C</p> <p>Hand soldering condition: The soldering iron tip temperature should be less than 300°C and maximum contract time should be 5 sec.</p>
Soldering heat	Resistance change rate is: ±(1%+0.05Ω) Max.	4.18 Dip the resistor into a solder bath having a temperature of 260°C±3°C and hold it for 10±1 seconds.

Anti Surge SMD Resistor



Performance specification :

Characteristics	Limits	Test Methods (JIS C 5201-1)															
Temperature cycling	Resistance Change Rate Is± (1.0% + 0.05Ω) Max.	4.19 Resistance change after continuous 5 cycles for duty cycle specified below :															
		<table border="1"> <thead> <tr> <th>Step</th> <th>Temperature</th> <th>Time</th> </tr> </thead> <tbody> <tr> <td>1</td> <td>-55°C ± 3°C</td> <td>30 mins</td> </tr> <tr> <td>2</td> <td>Room temp.</td> <td>10~15 mins</td> </tr> <tr> <td>3</td> <td>+155°C ± 2°C</td> <td>30 mins</td> </tr> <tr> <td>4</td> <td>Room temp.</td> <td>10~15 mins</td> </tr> </tbody> </table>	Step	Temperature	Time	1	-55°C ± 3°C	30 mins	2	Room temp.	10~15 mins	3	+155°C ± 2°C	30 mins	4	Room temp.	10~15 mins
		Step	Temperature	Time													
		1	-55°C ± 3°C	30 mins													
		2	Room temp.	10~15 mins													
3	+155°C ± 2°C	30 mins															
4	Room temp.	10~15 mins															
Humidity	Resistance change rate is ± (3.0% + 0.1Ω) Max.	4.24 Temporary resistance change after 240 hours exposure in a humidity test chamber controlled at 40 ±2°C and 90-95% relative humidity															
Load life in humidity	Resistance change rate is ± (3.0% + 0.1Ω) Max.	7.9 Resistance change after 1,000 hours (1.5 hours "on", 0.5 hour "off") at RCWV in a humidity chamber controlled at 40°C ± 2°C and 90 to 95 % relative humidity															
Load Life	Resistance change rate is ± (3.0% + 0.1Ω) Max.	4.25.1 Permanent resistance change after 1,000 hours operating at RCWV, with duty cycle of (1.5 hours"on", 0.5 hour"off") at 70°C ± 2°C ambient															
Terminal bending	Resistance change rate is ±(1.0% + 0.05Ω) Max.	4.33 Twist of Test Board : Y/X = 3/90 mm for 60 seconds															

Environment Related Substance

This product complies to EU RoHS directive, EU PAHs directive, EU PFOS directive and Halogen free.

Ozone layer depleting substances.

Ozone depleting substances are not used in our manufacturing process of this product.

This product is not manufactured using Chloro fluorocarbons (CFCs), Hydrochlorofluorocarbons (HCFCs), Hydrobromofluorocarbons (HBFCs) or other ozone depleting substances in any phase of the manufacturing process.

Storage Condition

The performance of these products, including the solderability, is guaranteed for a year from the date of arrival at your company, provided that they remain packed as they were when delivered and stored at a temperature of $25^{\circ}\text{C} \pm 10^{\circ}\text{C}$ and a relative humidity of $60\%RH \pm 10\%RH$, chemical and dust free atmosphere

Even within the above guarantee periods, do not store these products in the following conditions.

Otherwise, their electrical performance and/or solderability may be deteriorated, and the packaging materials (e.g. taping materials) may be deformed or deteriorated, resulting in mounting failures.

1. In salty air or in air with a high concentration of corrosive gas, such as Cl_2 , H_2S , NH_3 , SO_2 , or NO_2
2. In direct sunlight