



MMBZxVAL series

Double ESD protection diodes for transient overvoltage suppression

Rev. 01 — 1 September 2008

Product data sheet

1. Product profile

1.1 General description

Unidirectional double ElectroStatic Discharge (ESD) protection diodes in a common anode configuration, encapsulated in a SOT23 (TO-236AB) small Surface-Mounted Device (SMD) plastic package. The devices are designed for ESD and transient overvoltage protection of up to two signal lines.

Table 1. Product overview

| Type number ^[1] | Package | | Configuration |
|----------------------------|---------|----------|-------------------|
| | NXP | JEDEC | |
| MMBZ12VAL | SOT23 | TO-236AB | dual common anode |
| MMBZ15VAL | | | |
| MMBZ18VAL | | | |
| MMBZ20VAL | | | |
| MMBZ27VAL | | | |
| MMBZ33VAL | | | |

[1] All types available as /DG halogen-free version.

1.2 Features

- Unidirectional ESD protection of two lines
- Bidirectional ESD protection of one line
- Low diode capacitance: $C_d \leq 140$ pF
- Rated peak pulse power: $P_{PPM} \leq 40$ W
- Ultra low leakage current: $I_{RM} \leq 5$ nA
- ESD protection up to 30 kV (contact discharge)
- IEC 61000-4-2; level 4 (ESD)
- IEC 61643-321
- AEC-Q101 qualified

1.3 Applications

- Computers and peripherals
- Audio and video equipment
- Cellular handsets and accessories
- Automotive electronic control units
- Portable electronics

1.4 Quick reference data

Table 2. Quick reference data
T_{amb} = 25 °C unless otherwise specified.

| Symbol | Parameter | Conditions | Min | Typ | Max | Unit |
|---------------------------|---------------------------|-------------------|---------------------------------|-----|------|------|
| Per diode | | | | | | |
| V _{RWM} | reverse standoff voltage | | | | | |
| | MMBZ12VAL MMBZ12VAL/DG | | - | - | 8.5 | V |
| | MMBZ15VAL MMBZ15VAL/DG | | - | - | 12 | V |
| | MMBZ18VAL MMBZ18VAL/DG | | - | - | 14.5 | V |
| | MMBZ20VAL MMBZ20VAL/DG | | - | - | 17 | V |
| | MMBZ27VAL MMBZ27VAL/DG | | - | - | 22 | V |
| | MMBZ33VAL MMBZ33VAL/DG | | - | - | 26 | V |
| | C _d | diode capacitance | f = 1 MHz; V _R = 0 V | | | |
| MMBZ12VAL MMBZ12VAL/DG | | | - | 110 | 140 | pF |
| MMBZ15VAL MMBZ15VAL/DG | | | - | 85 | 105 | pF |
| MMBZ18VAL MMBZ18VAL/DG | | | - | 70 | 90 | pF |
| MMBZ20VAL MMBZ20VAL/DG | | | - | 65 | 80 | pF |
| MMBZ27VAL MMBZ27VAL/DG | | | - | 48 | 60 | pF |
| MMBZ33VAL MMBZ33VAL/DG | | | - | 45 | 55 | pF |

2. Pinning information

Table 3. Pinning

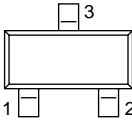
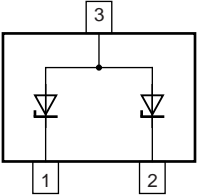
| Pin | Description | Simplified outline | Graphic symbol |
|-----|-------------------|--|---|
| 1 | cathode (diode 1) |  |  |
| 2 | cathode (diode 2) | | |
| 3 | common anode | | |

006aaa154

3. Ordering information

Table 4. Ordering information

| Type number | Package | | |
|--------------|---------|--|---------|
| | Name | Description | Version |
| MMBZ12VAL | - | plastic surface-mounted package; 3 leads | SOT23 |
| MMBZ15VAL | | | |
| MMBZ18VAL | | | |
| MMBZ20VAL | | | |
| MMBZ27VAL | | | |
| MMBZ33VAL | | | |
| MMBZ12VAL/DG | - | plastic surface-mounted package; 3 leads | SOT23 |
| MMBZ15VAL/DG | | | |
| MMBZ18VAL/DG | | | |
| MMBZ20VAL/DG | | | |
| MMBZ27VAL/DG | | | |
| MMBZ33VAL/DG | | | |

4. Marking

Table 5. Marking codes

| Type number | Marking code ^[1] | Type number | Marking code ^[1] |
|-------------|-----------------------------|--------------|-----------------------------|
| MMBZ12VAL | *H1 | MMBZ12VAL/DG | TH* |
| MMBZ15VAL | *H2 | MMBZ15VAL/DG | TK* |
| MMBZ18VAL | *H3 | MMBZ18VAL/DG | TM* |
| MMBZ20VAL | *H4 | MMBZ20VAL/DG | TP* |
| MMBZ27VAL | *H5 | MMBZ27VAL/DG | TR* |
| MMBZ33VAL | *H6 | MMBZ33VAL/DG | TT* |

- [1] * = -: made in Hong Kong
 * = p: made in Hong Kong
 * = t: made in Malaysia
 * = W: made in China

5. Limiting values

Table 6. Limiting values

In accordance with the Absolute Maximum Rating System (IEC 60134).

| Symbol | Parameter | Conditions | Min | Max | Unit |
|-------------------|---------------------------|--|----------|------|------------------|
| Per diode | | | | | |
| P_{PPM} | rated peak pulse power | $t_p = 10/1000 \mu s$ | [1][2] - | 40 | W |
| I_{PPM} | rated peak pulse current | $t_p = 10/1000 \mu s$ | [1][2] | | |
| | MMBZ12VAL MMBZ12VAL/DG | | - | 2.35 | A |
| | MMBZ15VAL MMBZ15VAL/DG | | - | 1.9 | A |
| | MMBZ18VAL MMBZ18VAL/DG | | - | 1.6 | A |
| | MMBZ20VAL MMBZ20VAL/DG | | - | 1.4 | A |
| | MMBZ27VAL MMBZ27VAL/DG | | - | 1 | A |
| | MMBZ33VAL MMBZ33VAL/DG | | - | 0.87 | A |
| Per device | | | | | |
| P_{tot} | total power dissipation | $T_{amb} \leq 25 \text{ }^\circ\text{C}$ | [3] - | 265 | mW |
| | | | [4] - | 360 | mW |
| T_j | junction temperature | | - | 150 | $^\circ\text{C}$ |
| T_{amb} | ambient temperature | | -55 | +150 | $^\circ\text{C}$ |
| T_{stg} | storage temperature | | -65 | +150 | $^\circ\text{C}$ |

[1] In accordance with IEC 61643-321 (10/1000 μs current waveform).

[2] Measured from pin 1 or 2 to pin 3.

[3] Device mounted on an FR4 Printed-Circuit Board (PCB), single-sided copper, tin-plated and standard footprint.

[4] Device mounted on an FR4 PCB, single-sided copper, tin-plated, mounting pad for cathode 1 cm².

Table 7. ESD maximum ratings

$T_{amb} = 25 \text{ }^\circ\text{C}$ unless otherwise specified.

| Symbol | Parameter | Conditions | Min | Max | Unit |
|------------------|---------------------------------|--------------------------------------|--------|-----|------|
| Per diode | | | | | |
| V_{ESD} | electrostatic discharge voltage | | [1][2] | | |
| | | IEC 61000-4-2 (contact discharge) | - | 30 | kV |
| | | machine model | - | 2 | kV |

[1] Device stressed with ten non-repetitive ESD pulses.

[2] Measured from pin 1 or 2 to pin 3.

Table 8. ESD standards compliance

| Standard | Conditions |
|---|---------------------------------|
| Per diode | |
| IEC 61000-4-2; level 4 (ESD) | > 15 kV (air); > 8 kV (contact) |
| MIL-STD-883; class 3 (human body model) | > 8 kV |

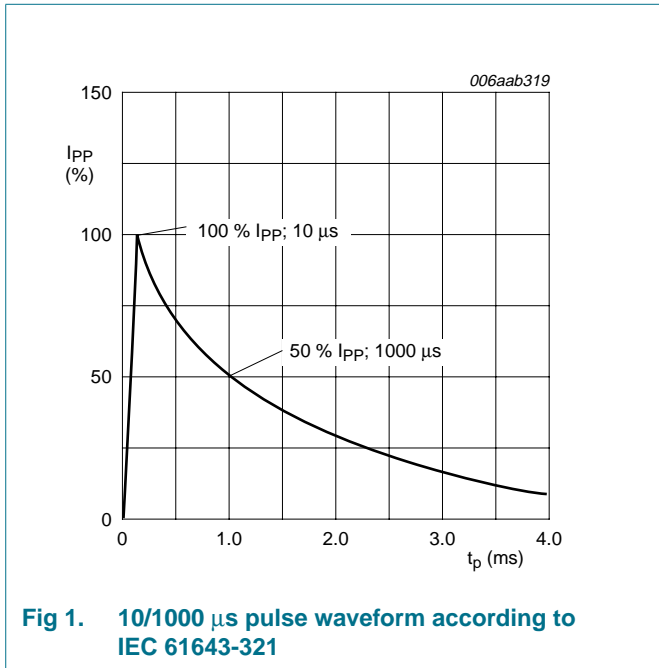

Fig 1. 10/1000 μs pulse waveform according to IEC 61643-321

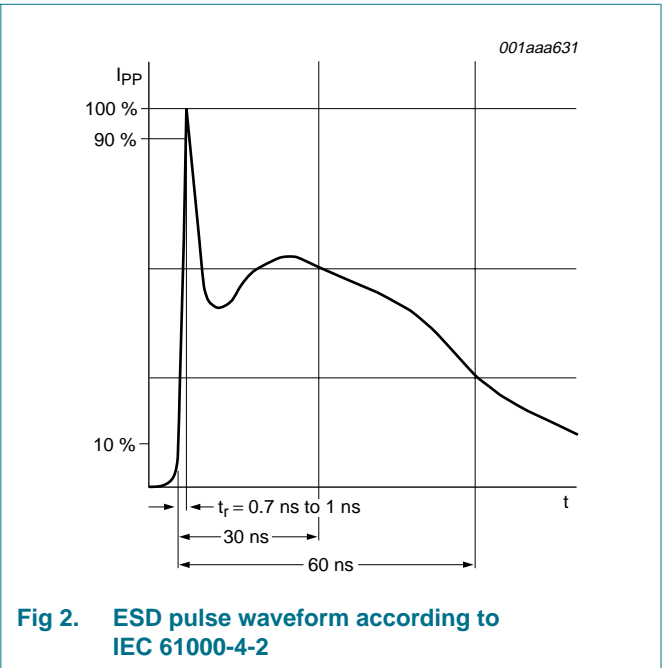

Fig 2. ESD pulse waveform according to IEC 61000-4-2

6. Thermal characteristics

Table 9. Thermal characteristics

| Symbol | Parameter | Conditions | Min | Typ | Max | Unit |
|-----------------------|--|-------------|-------|-----|-----|------|
| Per device | | | | | | |
| R _{th(j-a)} | thermal resistance from junction to ambient | in free air | [1] - | - | 460 | K/W |
| | | | [2] - | - | 340 | K/W |
| R _{th(j-sp)} | thermal resistance from junction to solder point | | [3] - | - | 50 | K/W |

[1] Device mounted on an FR4 PCB, single-sided copper, tin-plated and standard footprint.

[2] Device mounted on an FR4 PCB, single-sided copper, tin-plated, mounting pad for cathode 1 cm².

[3] Measured from pin 1 or 2 to pin 3.

7. Characteristics

Table 10. Characteristics
T_{amb} = 25 °C unless otherwise specified.

| Symbol | Parameter | Conditions | Min | Typ | Max | Unit |
|------------------|---------------------------|---------------------------|-------|-----|-------|------|
| Per diode | | | | | | |
| V _F | forward voltage | I _F = 10 mA | - | - | 0.9 | V |
| V _{RWM} | reverse standoff voltage | | | | | |
| | MMBZ12VAL MMBZ12VAL/DG | | - | - | 8.5 | V |
| | MMBZ15VAL MMBZ15VAL/DG | | - | - | 12 | V |
| | MMBZ18VAL MMBZ18VAL/DG | | - | - | 14.5 | V |
| | MMBZ20VAL MMBZ20VAL/DG | | - | - | 17 | V |
| | MMBZ27VAL MMBZ27VAL/DG | | - | - | 22 | V |
| | MMBZ33VAL MMBZ33VAL/DG | | - | - | 26 | V |
| I _{RM} | reverse leakage current | | | | | |
| | MMBZ12VAL MMBZ12VAL/DG | V _{RWM} = 8.5 V | - | 0.1 | 5 | nA |
| | MMBZ15VAL MMBZ15VAL/DG | V _{RWM} = 12 V | - | 0.1 | 5 | nA |
| | MMBZ18VAL MMBZ18VAL/DG | V _{RWM} = 14.5 V | - | 0.1 | 5 | nA |
| | MMBZ20VAL MMBZ20VAL/DG | V _{RWM} = 17 V | - | 0.1 | 5 | nA |
| | MMBZ27VAL MMBZ27VAL/DG | V _{RWM} = 22 V | - | 0.1 | 5 | nA |
| | MMBZ33VAL MMBZ33VAL/DG | V _{RWM} = 26 V | - | 0.1 | 5 | nA |
| V _{BR} | breakdown voltage | I _R = 1 mA | | | | |
| | MMBZ12VAL MMBZ12VAL/DG | | 11.4 | 12 | 12.6 | V |
| | MMBZ15VAL MMBZ15VAL/DG | | 14.25 | 15 | 15.75 | V |
| | MMBZ18VAL MMBZ18VAL/DG | | 17.1 | 18 | 18.9 | V |
| | MMBZ20VAL MMBZ20VAL/DG | | 19 | 20 | 21 | V |
| | MMBZ27VAL MMBZ27VAL/DG | | 25.65 | 27 | 28.35 | V |
| | MMBZ33VAL MMBZ33VAL/DG | | 31.35 | 33 | 34.65 | V |

Table 10. Characteristics ...continued

 $T_{amb} = 25^{\circ}\text{C}$ unless otherwise specified.

| Symbol | Parameter | Conditions | Min | Typ | Max | Unit |
|----------|---------------------------|--------------------------------------|--------|------|-----|------|
| C_d | diode capacitance | $f = 1\text{ MHz}; V_R = 0\text{ V}$ | | | | |
| | MMBZ12VAL MMBZ12VAL/DG | | - | 110 | 140 | pF |
| | MMBZ15VAL MMBZ15VAL/DG | | - | 85 | 105 | pF |
| | MMBZ18VAL MMBZ18VAL/DG | | - | 70 | 90 | pF |
| | MMBZ20VAL MMBZ20VAL/DG | | - | 65 | 80 | pF |
| | MMBZ27VAL MMBZ27VAL/DG | | - | 48 | 60 | pF |
| | MMBZ33VAL MMBZ33VAL/DG | | - | 45 | 55 | pF |
| V_{CL} | clamping voltage | | [1][2] | | | |
| | MMBZ12VAL MMBZ12VAL/DG | $I_{PPM} = 2.35\text{ A}$ | - | - | 17 | V |
| | MMBZ15VAL MMBZ15VAL/DG | $I_{PPM} = 1.9\text{ A}$ | - | - | 21 | V |
| | MMBZ18VAL MMBZ18VAL/DG | $I_{PPM} = 1.6\text{ A}$ | - | - | 25 | V |
| | MMBZ20VAL MMBZ20VAL/DG | $I_{PPM} = 1.4\text{ A}$ | - | - | 28 | V |
| | MMBZ27VAL MMBZ27VAL/DG | $I_{PPM} = 1\text{ A}$ | - | - | 40 | V |
| | MMBZ33VAL MMBZ33VAL/DG | $I_{PPM} = 0.87\text{ A}$ | - | - | 46 | V |
| S_z | temperature coefficient | $I_z = 1\text{ mA}$ | | | | |
| | MMBZ12VAL MMBZ12VAL/DG | | - | 8.2 | - | mV/K |
| | MMBZ15VAL MMBZ15VAL/DG | | - | 11 | - | mV/K |
| | MMBZ18VAL MMBZ18VAL/DG | | - | 14 | - | mV/K |
| | MMBZ20VAL MMBZ20VAL/DG | | - | 15.8 | - | mV/K |
| | MMBZ27VAL MMBZ27VAL/DG | | - | 23 | - | mV/K |
| | MMBZ33VAL MMBZ33VAL/DG | | - | 29.8 | - | mV/K |

[1] In accordance with IEC 61643-321(10/1000 μs current waveform).

[2] Measured from pin 1 or 2 to pin 3.

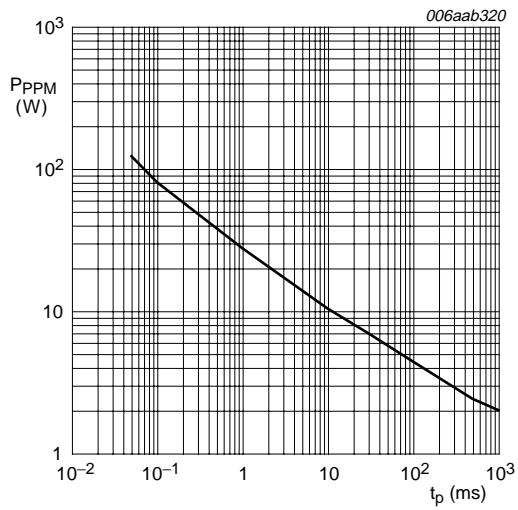

MMBZ27VAL: unidirectional and bidirectional
 $T_{amb} = 25\text{ }^{\circ}\text{C}$

Fig 3. Rated peak pulse power as a function of exponential pulse duration (rectangular waveform); typical values

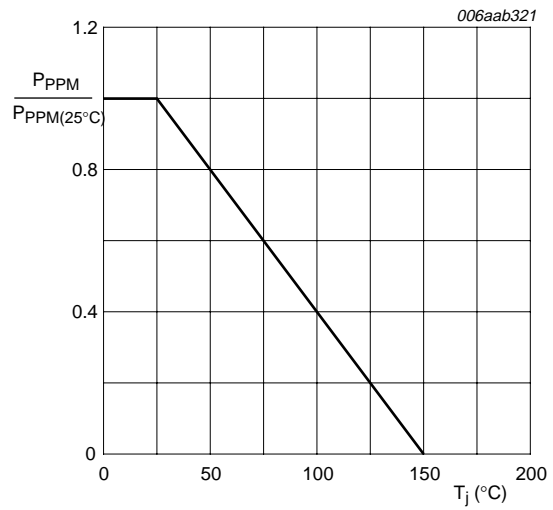
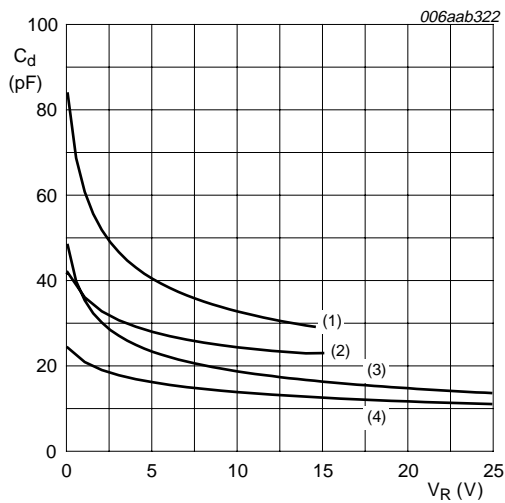
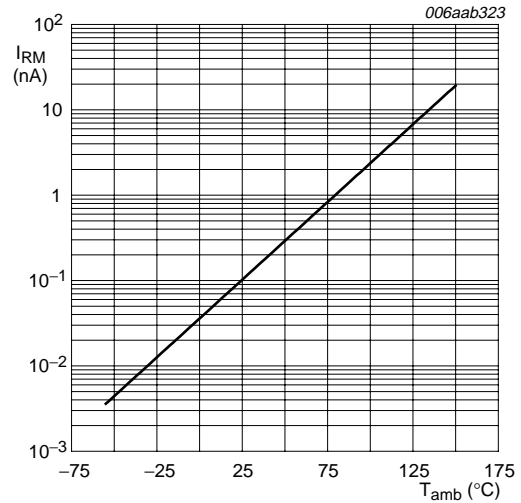

Fig 4. Relative variation of rated peak pulse power as a function of junction temperature; typical values



$f = 1\text{ MHz}; T_{amb} = 25\text{ }^{\circ}\text{C}$
 (1) MMBZ15VAL: unidirectional
 (2) MMBZ15VAL: bidirectional
 (3) MMBZ27VAL: unidirectional
 (4) MMBZ27VAL: bidirectional

Fig 5. Diode capacitance as a function of reverse voltage; typical values



MMBZ27VAL: $V_{RWM} = 22\text{ V}$

Fig 6. Reverse leakage current as a function of ambient temperature; typical values

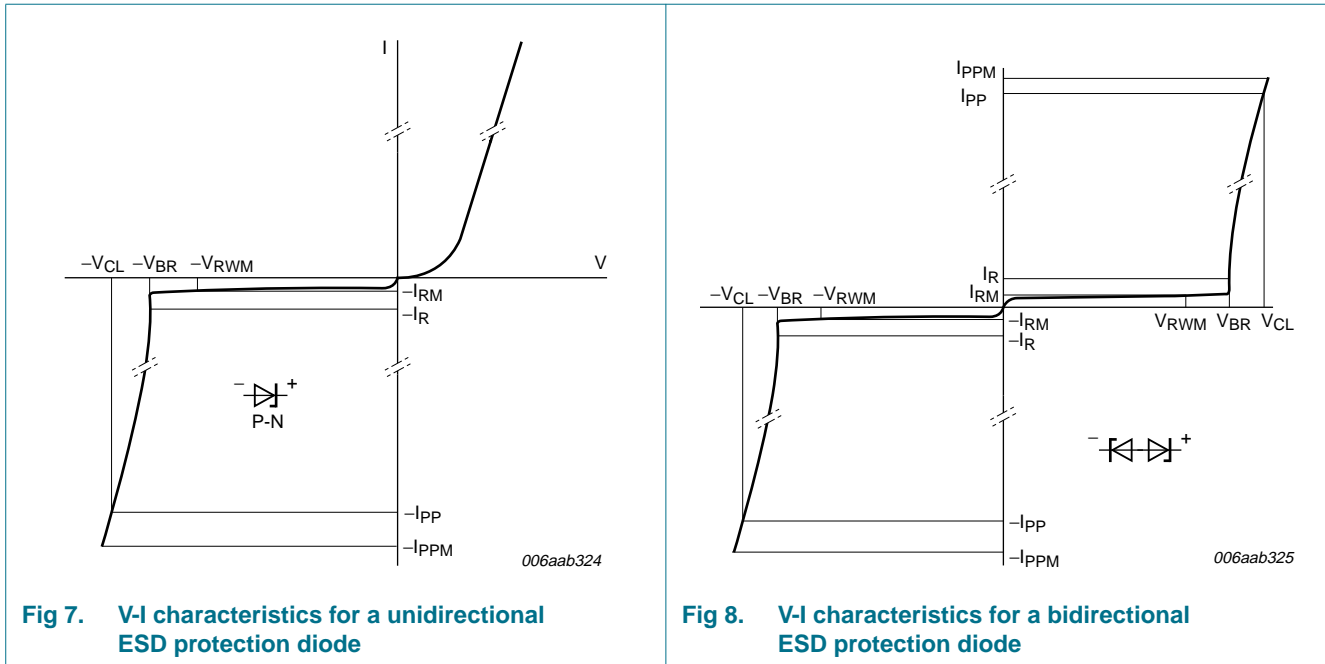

8. Application information

The MMBZxVAL series is designed for the protection of up to two unidirectional data or signal lines from the damage caused by ESD and surge pulses. The devices may be used on lines where the signal polarities are either positive or negative with respect to ground. The devices provide a surge capability of 40 W per line for a 10/1000 μ s waveform.

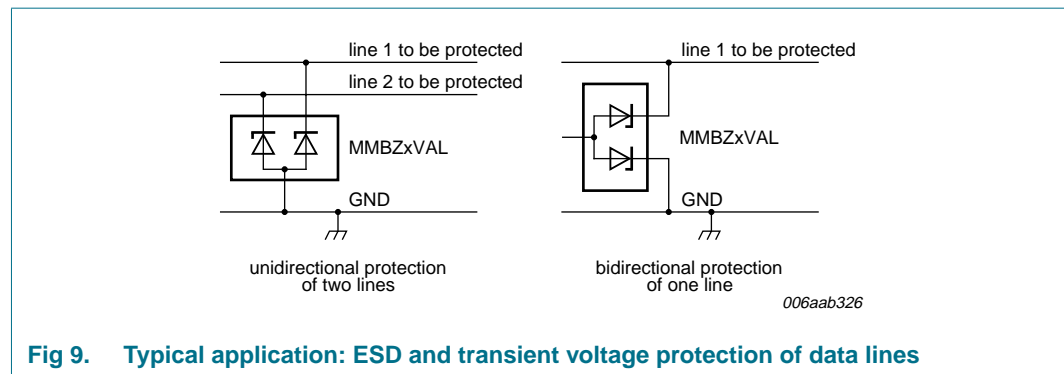

11. Packing information

Table 11. Packing methods

The indicated -xxx are the last three digits of the 12NC ordering code.^[1]

| Type number | Package | Description | Packing quantity | |
|--------------|---------|--------------------------------|------------------|-------|
| | | | 3000 | 10000 |
| MMBZ12VAL | SOT23 | 4 mm pitch, 8 mm tape and reel | -215 | -235 |
| MMBZ15VAL | | | | |
| MMBZ18VAL | | | | |
| MMBZ20VAL | | | | |
| MMBZ27VAL | | | | |
| MMBZ33VAL | | | | |
| MMBZ12VAL/DG | SOT23 | 4 mm pitch, 8 mm tape and reel | -215 | -235 |
| MMBZ15VAL/DG | | | | |
| MMBZ18VAL/DG | | | | |
| MMBZ20VAL/DG | | | | |
| MMBZ27VAL/DG | | | | |
| MMBZ33VAL/DG | | | | |

[1] For further information and the availability of packing methods, see [Section 15](#).

12. Soldering

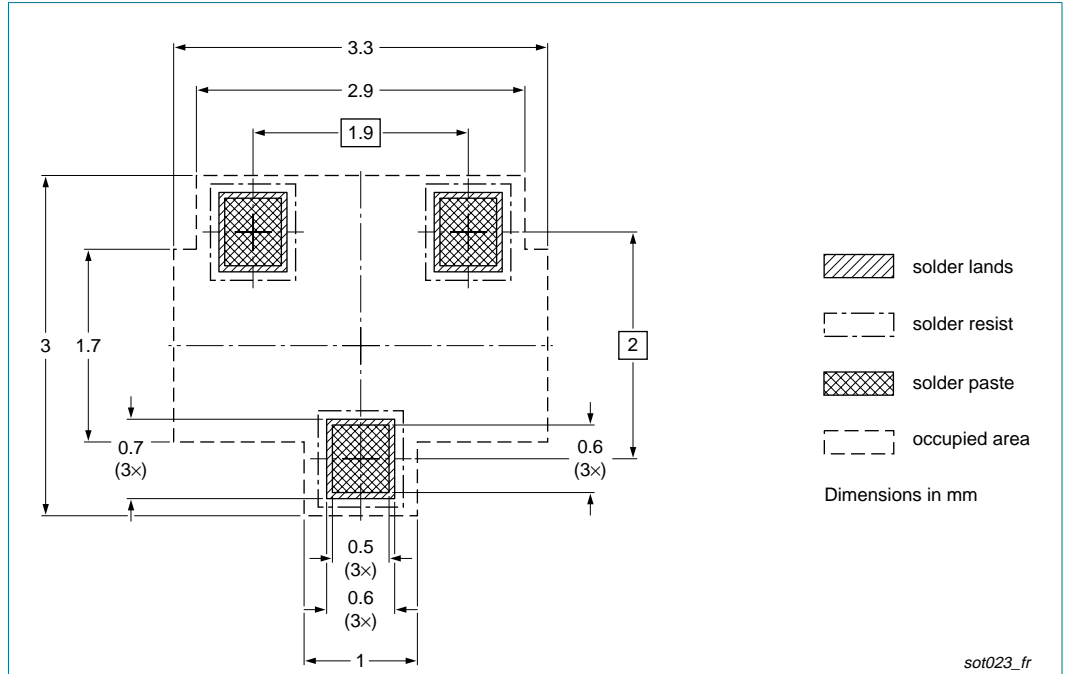

Fig 11. Reflow soldering footprint SOT23 (TO-236AB)

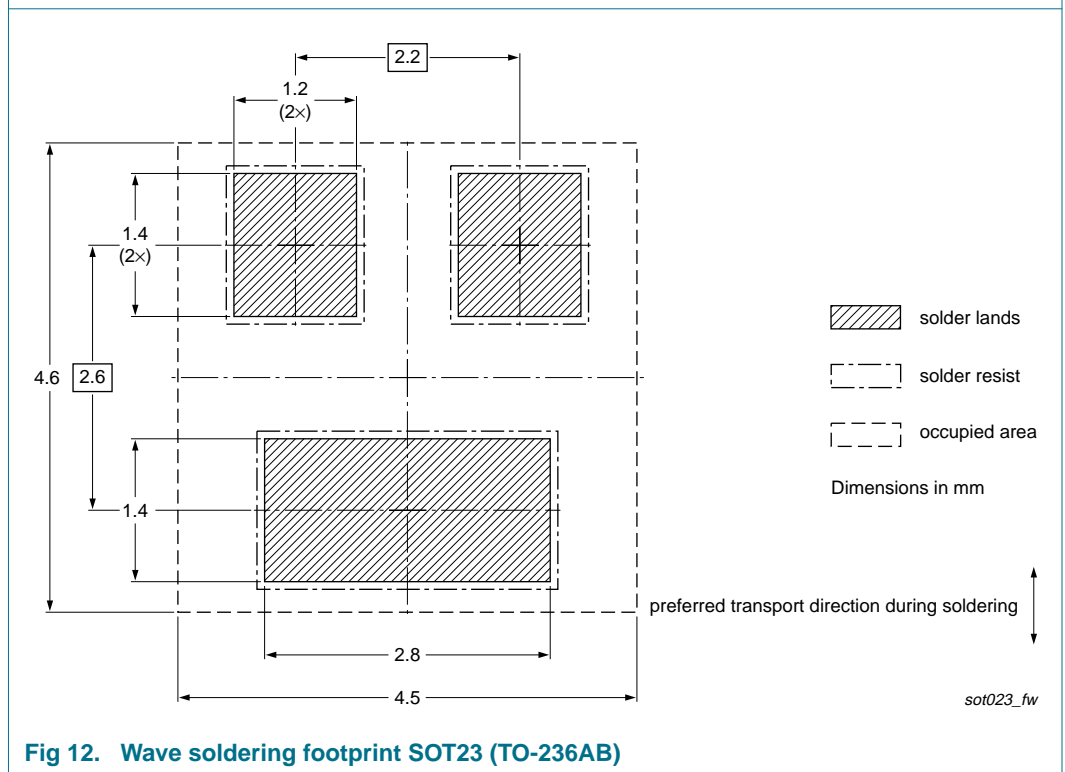

Fig 12. Wave soldering footprint SOT23 (TO-236AB)

13. Revision history

Table 12. Revision history

| Document ID | Release date | Data sheet status | Change notice | Supersedes |
|----------------|--------------|--------------------|---------------|------------|
| MMBZXVAL_SER_1 | 20080901 | Product data sheet | - | - |

14. Legal information

14.1 Data sheet status

| Document status ^{[1][2]} | Product status ^[3] | Definition |
|-----------------------------------|-------------------------------|---|
| Objective [short] data sheet | Development | This document contains data from the objective specification for product development. |
| Preliminary [short] data sheet | Qualification | This document contains data from the preliminary specification. |
| Product [short] data sheet | Production | This document contains the product specification. |

[1] Please consult the most recently issued document before initiating or completing a design.

[2] The term 'short data sheet' is explained in section "Definitions".

[3] The product status of device(s) described in this document may have changed since this document was published and may differ in case of multiple devices. The latest product status information is available on the Internet at URL <http://www.nxp.com>.

14.2 Definitions

Draft — The document is a draft version only. The content is still under internal review and subject to formal approval, which may result in modifications or additions. NXP Semiconductors does not give any representations or warranties as to the accuracy or completeness of information included herein and shall have no liability for the consequences of use of such information.

Short data sheet — A short data sheet is an extract from a full data sheet with the same product type number(s) and title. A short data sheet is intended for quick reference only and should not be relied upon to contain detailed and full information. For detailed and full information see the relevant full data sheet, which is available on request via the local NXP Semiconductors sales office. In case of any inconsistency or conflict with the short data sheet, the full data sheet shall prevail.

14.3 Disclaimers

General — Information in this document is believed to be accurate and reliable. However, NXP Semiconductors does not give any representations or warranties, expressed or implied, as to the accuracy or completeness of such information and shall have no liability for the consequences of use of such information.

Right to make changes — NXP Semiconductors reserves the right to make changes to information published in this document, including without limitation specifications and product descriptions, at any time and without notice. This document supersedes and replaces all information supplied prior to the publication hereof.

Suitability for use — NXP Semiconductors products are not designed, authorized or warranted to be suitable for use in medical, military, aircraft, space or life support equipment, nor in applications where failure or malfunction of an NXP Semiconductors product can reasonably be expected to result in personal injury, death or severe property or environmental damage. NXP Semiconductors accepts no liability for inclusion and/or use of NXP Semiconductors products in such equipment or applications and therefore such inclusion and/or use is at the customer's own risk.

Applications — Applications that are described herein for any of these products are for illustrative purposes only. NXP Semiconductors makes no representation or warranty that such applications will be suitable for the specified use without further testing or modification.

Limiting values — Stress above one or more limiting values (as defined in the Absolute Maximum Ratings System of IEC 60134) may cause permanent damage to the device. Limiting values are stress ratings only and operation of the device at these or any other conditions above those given in the Characteristics sections of this document is not implied. Exposure to limiting values for extended periods may affect device reliability.

Terms and conditions of sale — NXP Semiconductors products are sold subject to the general terms and conditions of commercial sale, as published at <http://www.nxp.com/profile/terms>, including those pertaining to warranty, intellectual property rights infringement and limitation of liability, unless explicitly otherwise agreed to in writing by NXP Semiconductors. In case of any inconsistency or conflict between information in this document and such terms and conditions, the latter will prevail.

No offer to sell or license — Nothing in this document may be interpreted or construed as an offer to sell products that is open for acceptance or the grant, conveyance or implication of any license under any copyrights, patents or other industrial or intellectual property rights.

Quick reference data — The Quick reference data is an extract of the product data given in the Limiting values and Characteristics sections of this document, and as such is not complete, exhaustive or legally binding.

ESD protection devices — These products are only intended for protection against ElectroStatic Discharge (ESD) pulses and are not intended for any other usage including, without limitation, voltage regulation applications. NXP Semiconductors accepts no liability for use in such applications and therefore such use is at the customer's own risk.

14.4 Trademarks

Notice: All referenced brands, product names, service names and trademarks are the property of their respective owners.

15. Contact information

For more information, please visit: <http://www.nxp.com>

For sales office addresses, please send an email to: salesaddresses@nxp.com

16. Contents

1 Product profile 1

1.1 General description 1

1.2 Features 1

1.3 Applications 1

1.4 Quick reference data 2

2 Pinning information 2

3 Ordering information 3

4 Marking 3

5 Limiting values 4

6 Thermal characteristics 5

7 Characteristics 6

8 Application information 9

9 Test information 10

9.1 Quality information 10

10 Package outline 10

11 Packing information 11

12 Soldering 12

13 Revision history 13

14 Legal information 14

14.1 Data sheet status 14

14.2 Definitions 14

14.3 Disclaimers 14

14.4 Trademarks 14

15 Contact information 14

16 Contents 15

Please be aware that important notices concerning this document and the product(s) described herein, have been included in section 'Legal information'.



© NXP B.V. 2008.

All rights reserved.

For more information, please visit: <http://www.nxp.com>

For sales office addresses, please send an email to: salesaddresses@nxp.com

Date of release: 1 September 2008

Document identifier: MMBZXVAL_SER_1