

DO NOT SCALE
DIMENSIONS IN mm

METRIC

THIRD ANGLE
PROJECTION

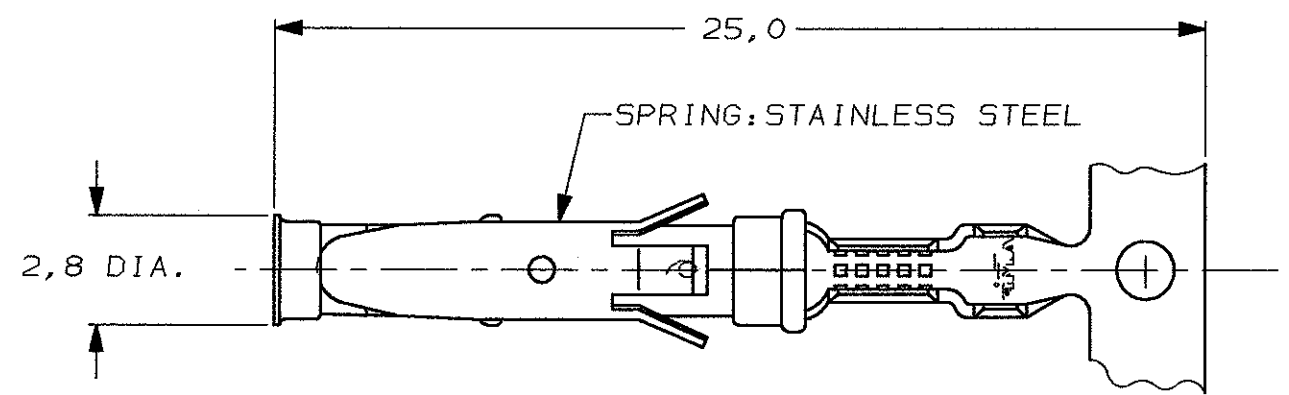

STRIP

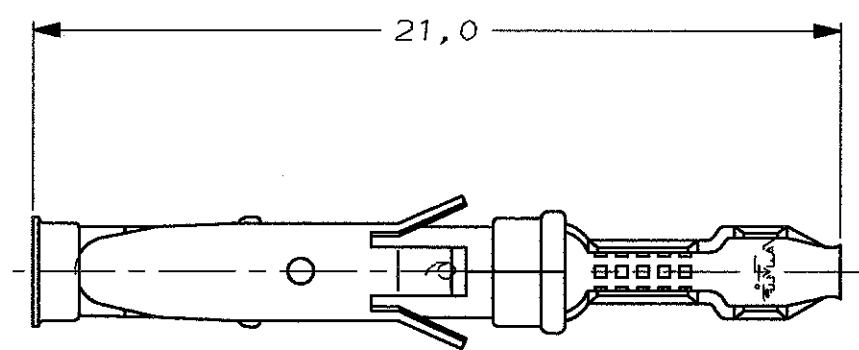

LOOSE-PIECE

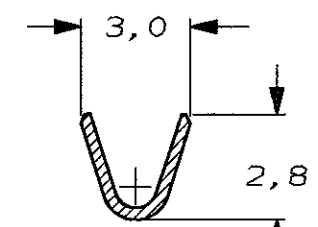
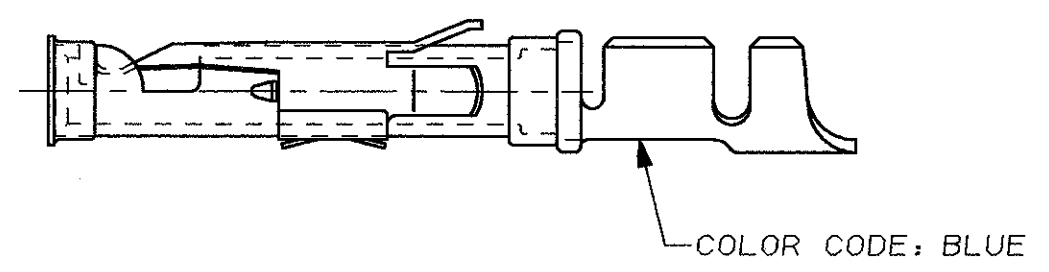
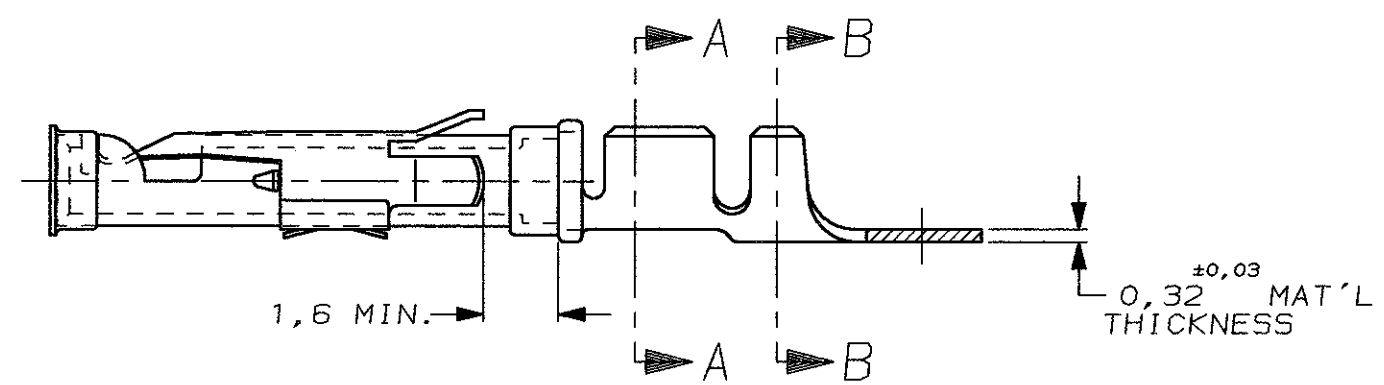

SECTION A-A

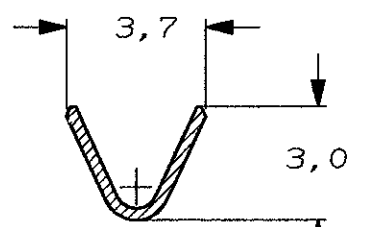

SECTION B-B

WIRE RANGE : 0,75-1,50 mm² (18-16 AWG)
INSUL. RANGE : 2,0 -2,5 mm (.080-.100)

DIRECTION OFF TOP OF REEL
AMPOMATOR + MINI-APPL.
107-3-F16.1 $\triangle A$
107-3-F16.2 $\triangle B$
107-3-F16.4 $\triangle C$

5-163083-3	$\triangle A$	$\triangle C$		BRASS	ECON. GOLD	$\triangle 21$
5-163083-2	$\triangle 1$	$\triangle 4$	$\triangle C$	BRASS	SEL. GOLD	$\triangle 22$
5-163083-1	$\triangle 1$	$\triangle 4$	$\triangle C$	BRASS	EL. TIN	$\triangle 20$
1-163083-4		$\triangle A$	1-163084-4	BRASS	EL. TIN	$\triangle 31$ $\triangle 20$
1-163083-3		$\triangle A$	1-163084-3	BRASS	BR. TIN/LEAD	$\triangle 30$
1-163083-2		$\triangle A$		BRASS	SILVER	$\triangle 28$
1-163083-1		$\triangle A$		BRASS	ECON. GOLD	$\triangle 21$
1-163083-0		$\triangle B$	1-163084-0	BRASS	ECON. GOLD	$\triangle 21$
163083-9		$\triangle B$		BRASS	SILVER	$\triangle 28$
163083-8		$\triangle A$		BRASS	EL. TIN	$\triangle 20$
163083-7		$\triangle A$		BRASS	SEL. GOLD	$\triangle 22$
163083-2	$\triangle 1$	$\triangle B$	163084-2	BRASS	SEL. GOLD	$\triangle 22$
163083-1	$\triangle 1$	$\triangle B$	163084-1	BRASS	EL. TIN	$\triangle 20$
PARTNUMBER	DIRECTION OF REEL	LOOSE-PIECE	MATERIAL	PLATING		

NOTES	MATERIAL	THICKNESS	AREA
$\triangle 20$	TIN	2,0 μ m	ALL OVER
$\triangle 21$	NICKEL GOLD TIN/LEAD	0,8 μ m	ALL OVER CONTACT AREA BARREL
$\triangle 22$	NICKEL GOLD GOLD	0,8 μ m	ALL OVER CONTACT AREA ALL OVER
$\triangle 23$	NICKEL GOLD GOLD	1,2 μ m	ALL OVER CONTACT AREA ALL OVER
$\triangle 24$	NICKEL SILVER TIN/LEAD	2,5 μ m	ALL OVER CONTACT AREA BARREL
$\triangle 25$	SILVER NICKEL	1,5-2,5 μ m 0,76 μ m	ALL OVER ALL OVER
$\triangle 26$	SILVER	2,5 μ m	ALL OVER
$\triangle 30$	NICKEL TIN/LEAD	1,27 μ m 1,27 μ m	ALL OVER ALL OVER
$\triangle 31$	LUBRICATED		

REV.	DESCRIPTION	DR.	CHK.	DATE	
AZ	EBD0-0003-05	AM	FWK	05/01/05	
AY	EBD0-0335-04	JMS	FWK	02/08/04	
V	EH-1020-98	D.K.	R.V.	08 JUL 98	
U	EH-1347-96	JvL	RV	21-11-96	
T	EH-0302-94	JvL	MvD	03-05-94	
S	ECN H-9813	JvdH	RD	18-05-92	
R	ECN H-9192	MvD	RD	09-10-91	
LTR.	REVISION RECORD	DR.	CHK.	DATE	
DR.	-	CHK.	-	APP.	-
DATE:	-	DATE:	-	DATE:	-

CUSTOMER DRAWING FOR REFERENCE ONLY
WILL NOT BE UPDATED

© COPYRIGHT 19- BY AMP HOLLAND B.V.
ALL INTERNATIONAL RIGHTS RESERVED. AMP PRODUCTS MAY BE
COVERED BY U.S. AND FOREIGN AND/OR PATENTS PENDING.
THIS DRAWING IS UNPUBLISHED
RELEASED FOR PUBLICATION _____, 19____

AMP | AMP HOLLAND B.V.
's-Hertogenbosch,
The Netherlands.

NAME _____

**SOCKET TYPE III CONTACT
SIZE 16**

DWG. No. 163083
REV. LTR. SHEET
AZ 1 OF 1 A3

NOTES :

- U.L. RECONIZED UNDER FILE E28476 VOL. VI SEC. I .
- FOR CRIMPDETAILS SEE AMP-SPEC. 114-19.000 .
- MEETS PRODUCTSPECIFICATION 108-10042.
- SPECIAL REEL WITH 200 PCS FOR REEL-FED HANDTOOL.