

BUD PART NAME	UTILIBOX (STYLE I)	PART No.	CU-3240 TO	CU-3245	REV. DATE	5-15-15
			CU-3240-MB TO	CU-3245-MB		

MATERIAL: ABS THERMOPLASTIC, UL94-5VA, BLACK TEXTURE

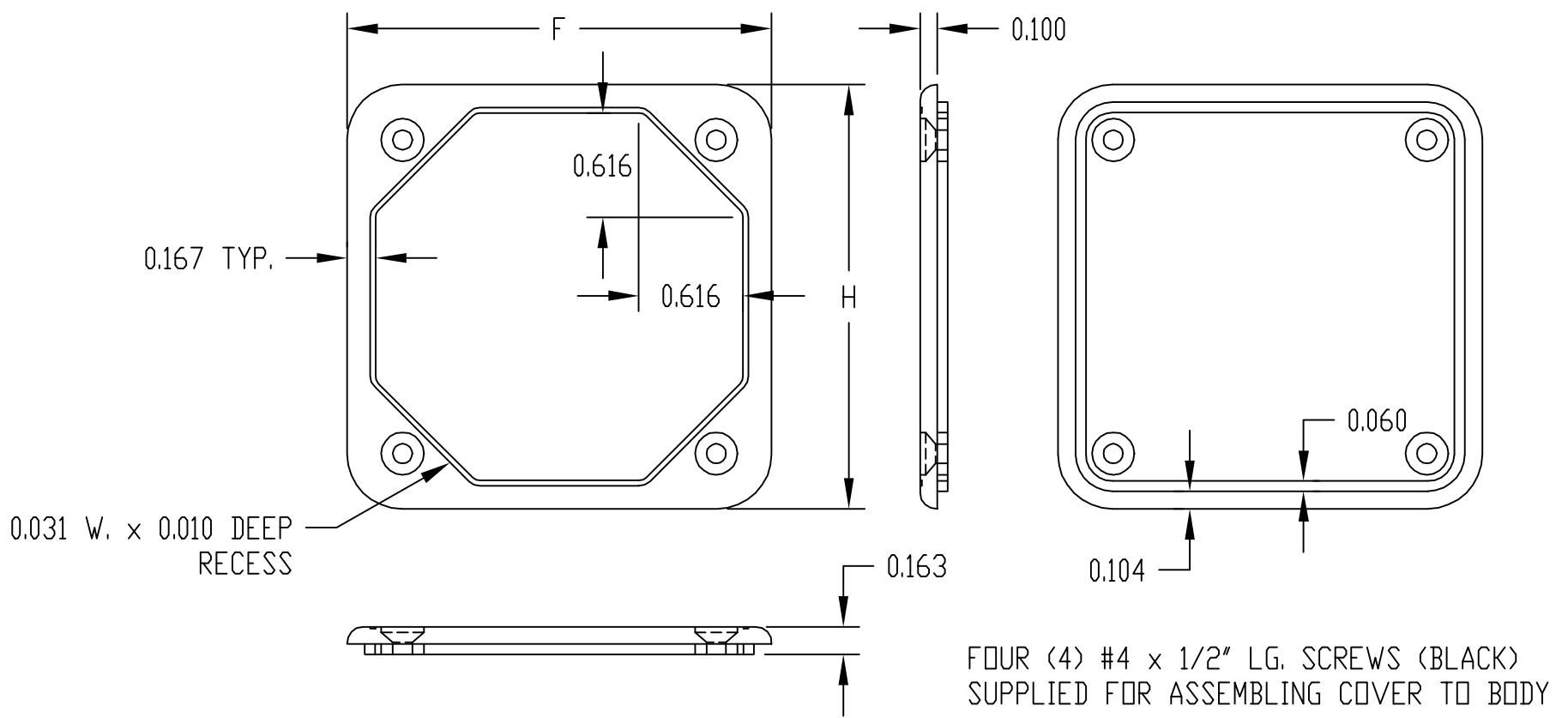

FOUR (4) #4 x 1/2" LG. SCREWS (BLACK) SUPPLIED FOR ASSEMBLING COVER TO BODY

MOUNTING BOSSES USE EITHER M2.5 METRIC OR #4 STD. SHEET METAL SCREWS x 1/4" LG. (NOT SUPPLIED)

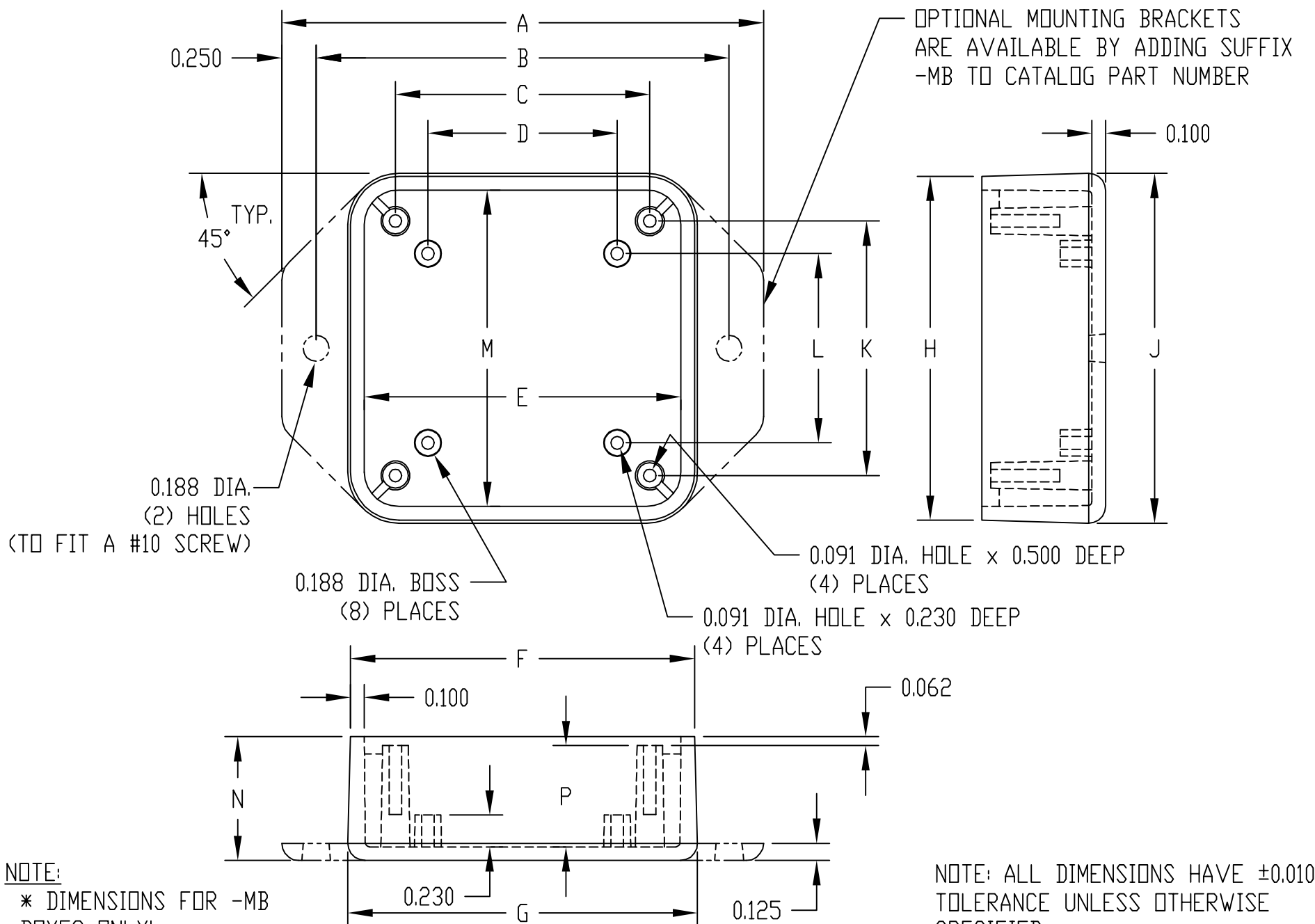

NOTE:
* DIMENSIONS FOR -MB BOXES ONLY!

NOTE: ALL DIMENSIONS HAVE ±0.010 TOLERANCE UNLESS OTHERWISE SPECIFIED

PART NO.	A *	B *	C	D	E	F	G	H	J	K	L	M	N	P
CU-3240	4.375	3.875	2.649	2.125	3.091	3.291	3.337	2.416	2.462	1.774	1.250	2.216	1.000	0.838
CU-3241	3.500	3.000	1.848	1.375	2.300	2.500	2.541	2.500	2.541	1.848	1.375	2.300	0.900	0.738
CU-3242	4.250	3.750	2.648	2.125	3.095	3.295	3.354	3.295	3.354	2.648	2.125	3.095	1.250	1.088
CU-3243	5.125	4.625	3.518	3.000	3.965	4.165	4.211	2.803	2.849	2.148	1.625	2.608	1.000	0.838
CU-3244	5.500	5.000	3.898	3.375	4.345	4.545	4.604	3.295	3.354	2.648	2.125	3.095	1.250	1.088
CU-3245	6.500	6.000	4.898	4.375	5.345	5.545	5.604	3.789	3.848	3.147	2.625	3.589	1.250	1.088