

DO NOT SCALE DRAWING

REVISION

A INITIAL DRAWING 24.9.15

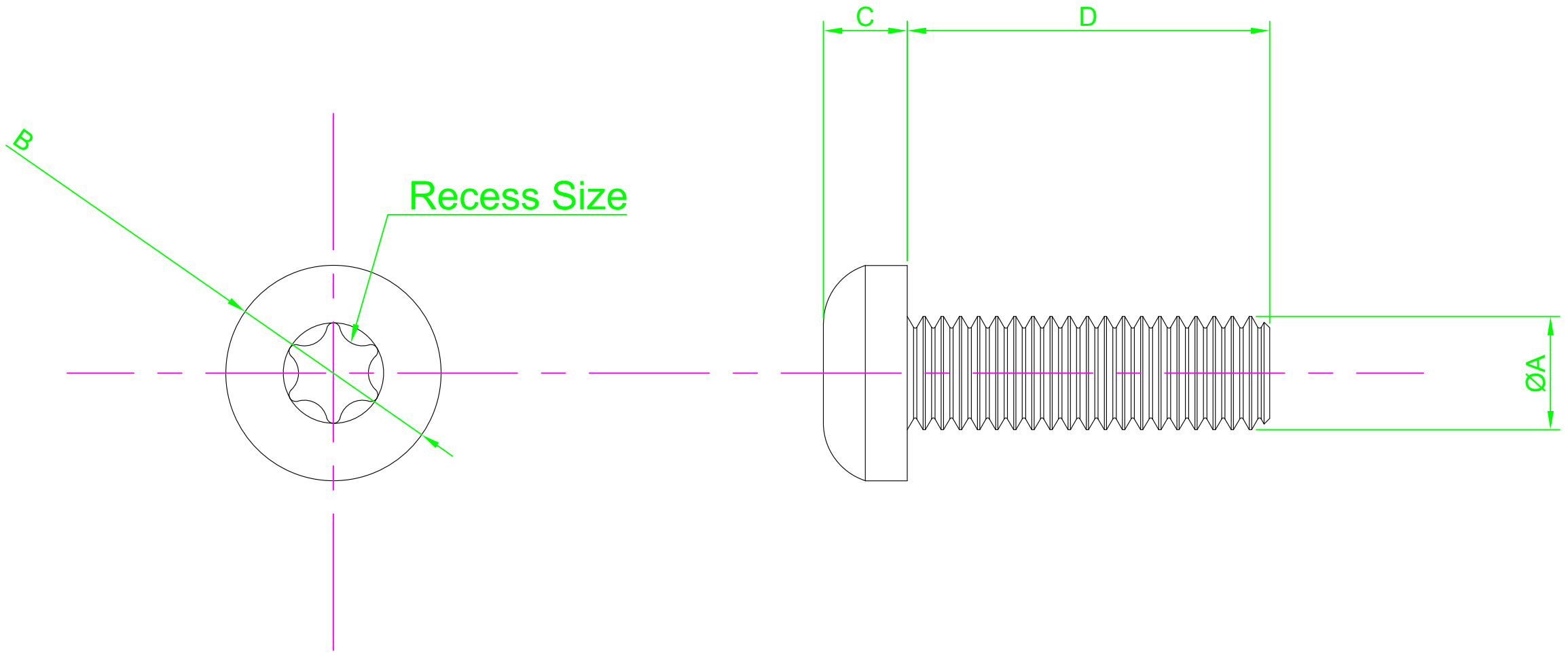

Part Number	ØA	B Nom	C Nom	Recess Size	D Length
M3 6 PTSTMC Z100	M3-0.5	6.0	2.4	T10	6
M3 12 PTSTMC Z100					12
M3 20 PTSTMC Z100					20
M4 12 PTSTMC Z100	M4-0.7	8.0	3.1	T20	12
M4 20 PTSTMC Z100					20
M5 20 PTSTMC Z100	M5-0.8	10.0	3.8	T25	20

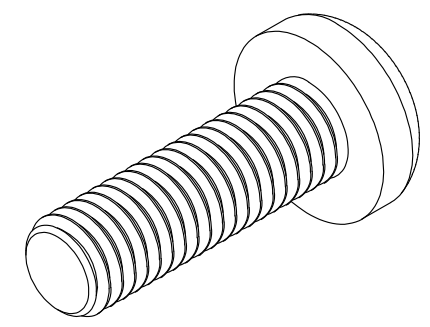

NOTES:



Fastenings

DESIGN RIGHT. TR FASTENINGS LTD. 2003
 UNDER NO CIRCUMSTANCES MUST THIS
 DRAWING BE COPIED OR DISCLOSED
 WITHOUT FIRST OBTAINING WRITTEN
 AUTHORITY.

UNLESS OTHERWISE SPECIFIED:
 DIMENSIONS ARE IN MM (MILLIMETERS).
 SURFACE FINISH:
 TOLERANCES: DIN 7985

	NAME	DATE
DRAWN	Darryl Wilson	24.09.15
CHK'D		
APPVD		

CUSTOMER PART NUMBER:
 N/A

MATERIAL:
 Steel

HEAT TREATMENT:

FINISH:
 TC1 - Commercial Zinc/Clear Trivalent

TITLE:
 Torx Pan Head Machine Screw

DRAWING NUMBER:
 TR32PTSTMC

A4