

Han E[®] / Han[®] ES / Han[®] ESS / Han[®] EE

Page

Technical characteristics Han E [®]	03.10
Technical characteristics Han [®] EE	03.11
Technical characteristics Han [®] ES	03.12
Technical characteristics Han [®] ESS	03.13
Han [®] 6 E / Han [®] 6 ES / Han [®] 6 ESS	03.14
Han [®] 10 EE	03.15
Han [®] 10 E / Han [®] 10 ES / Han [®] 10 ESS	03.18
Han [®] 18 EE	03.19
Han [®] 16 E / Han [®] 16 ES / Han [®] 16 ESS	03.22
Han [®] 32 EE	03.23
Han [®] 24 E / Han [®] 24 ES / Han [®] 24 ESS	03.26
Han [®] 46 EE	03.27
Han [®] 32 E / Han [®] 32 ES / Han [®] 32 ESS	03.30
Han [®] 64 EE	03.31
Han [®] 48 E / Han [®] 48 ES / Han [®] 48 ESS	03.33
Han [®] 92 EE	03.34
Modified contact arrangements	03.36

Han
E/EE

Specifications

DIN VDE 0627
DIN VDE 0110
DIN EN 61 984

Approvals



Inserts

Number of contacts 6, 10, 16, 24, 32 (2 x 16),
48 (2 x 24) + PE

Electrical data
acc. to DIN EN 61 984

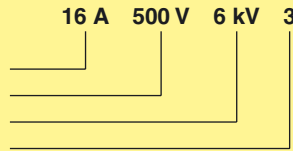

Working current
Working voltage
Rated impulse voltage
Pollution degree

– Pollution degree 2 also 16 A 400/690 V 6 kV 2

Working voltage
acc. to UL/CSA

600 V

Insulation resistance
Material
Limiting temperatures
Flammability acc. to UL 94
Mechanical working life
- Mating cycles

≥ 10¹⁰ Ω
Polycarbonate
- 40 °C / +125 °C
V 0
≥ 500

Contacts

Material copper alloy
Surface
- hard-silver plated 3 µm Ag
- hard-gold plated 2 µm Au over 3 µm Ni
Contact resistance ≤ 1 mΩ
Crimp terminal
- mm² 0.5 - 4.0 mm²
- AWG 20 - 12
- Stripping length 7.5 mm
Screw terminal
- mm² 1.0 - 2.5 mm²
- AWG 18 - 14
- Tightening/test torque 0.5 Nm
- Stripping length 7.0 mm

Hoods/Housings

Material die cast aluminium
Surface powder-coated RAL 7037
Locking element Han-Easy Lock®
Hoods/Housings seal NBR
Limiting temperatures - 40 °C / +125 °C
Degree of protection acc. to DIN EN 60 529 for coupled connector IP 65
Further selection of hoods/housings chapter 30 and chapter 31

Accessories

Crimping tools chapter 99
Cable clamps chapter 40
Coding of Hoods/Housings chapter 40
Label acc. to CSA-approval chapter 40
Han-Snap® chapter 11
Special insert fixing screws chapter 40

Current carrying capacity

The current carrying capacity is limited by maximum temperature of materials for inserts and contacts including terminals. The current capacity-curve is valid for continuous, not interrupted current-loaded contacts of connectors when simultaneous power on all contacts is given, without exceeding the maximum temperature.

Control and test procedures according to DIN IEC 60 512-3.

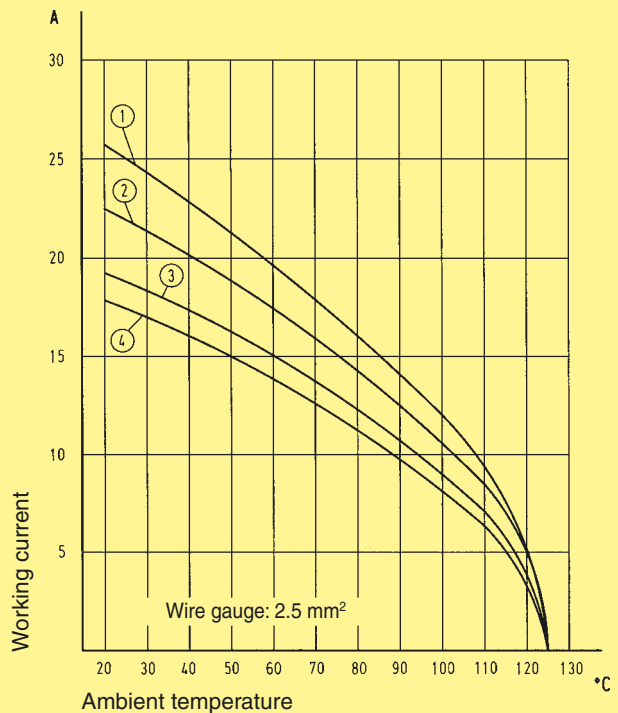
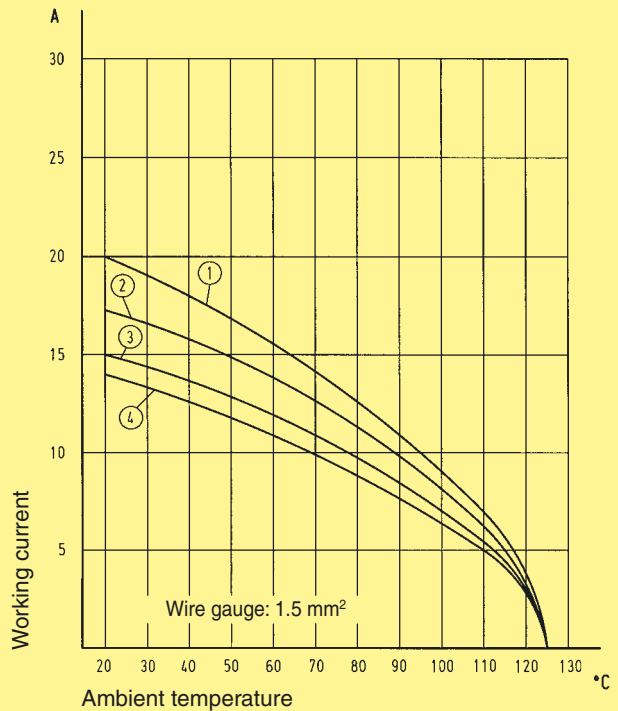

- ① Han® 6 E
- ② Han® 10 E
- ③ Han® 16 E
- ④ Han® 24 E

Specifications

DIN VDE 0627
DIN VDE 0110
DIN EN 61 984

Approvals



Inserts

Number of contacts 10, 18, 32, 46, 64 (2 x 32),
92 (2 x 46) + PE

Electrical data
acc. to DIN EN 61 984

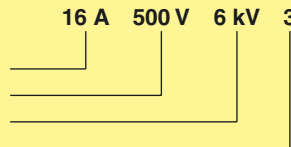

Working current
Working voltage
Rated impulse voltage
Pollution degree

– Pollution degree 2 also 16 A 830 V 8 kV 2

Working voltage
acc. to UL/CSA 600 V

Insulation resistance $\geq 10^{10} \Omega$
Material Polycarbonate
Limiting temperatures - 40 °C / +125 °C
Flammability acc. to UL 94 V 0
Mechanical working life
- Mating cycles ≥ 500

Contacts

Material copper alloy
Surface
- hard-silver plated 3 μm Ag
- hard-gold plated 2 μm Au over 3 μm Ni
Contact resistance $\leq 1 \text{ m}\Omega$
Crimp terminal
- mm^2 0.5 - 4.0 mm^2
- AWG 20 - 12
- Stripping length 7.5 mm

Hoods/Housings

Material die cast aluminium
Surface powder-coated
RAL 7037
Locking element Han-Easy Lock®
Hoods/Housings seal NBR
Limiting temperatures - 40 °C / +125 °C
Degree of protection
acc. to DIN EN 60 529
for coupled connector IP 65

Further selection
of hoods/housings chapter 30 / chapter 31

Accessories

Crimping tools chapter 99
Cable clamps chapter 40
Coding of Hoods/Housings chapter 40
Label acc. to CSA-approval chapter 40
Han-Snap® chapter 11
Special insert fixing screws chapter 40

Current carrying capacity

The current carrying capacity is limited by maximum temperature of materials for inserts and contacts including terminals. The current capacity-curve is valid for continuous, not interrupted current-loaded contacts of connectors when simultaneous power on all contacts is given, without exceeding the maximum temperature.

Control and test procedures according to DIN IEC 60 512-3.

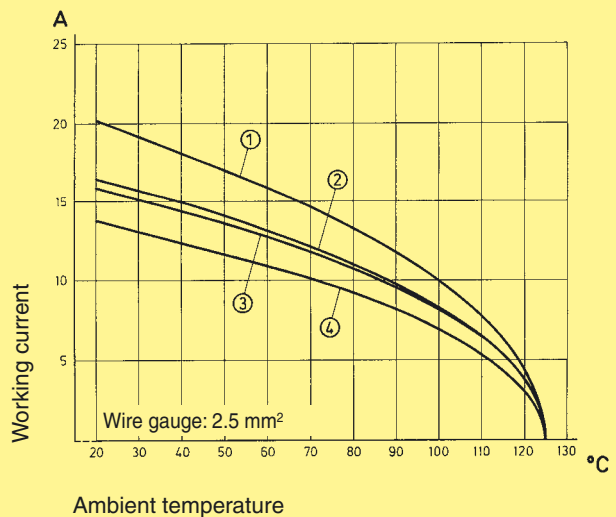
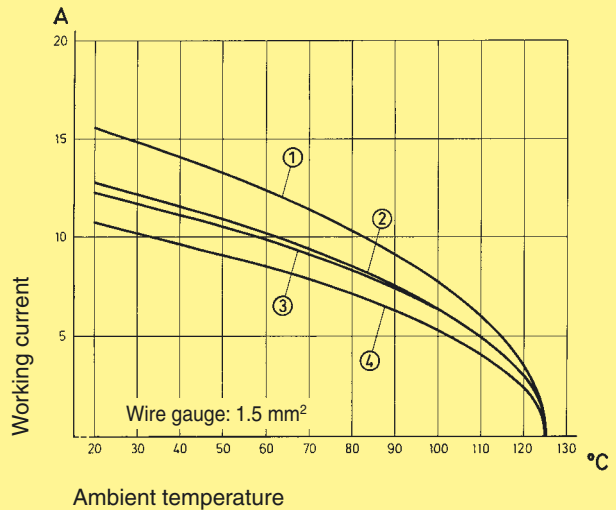

- ① Han® 10 EE
- ② Han® 18 EE
- ③ Han® 32 EE
- ④ Han® 46 EE

Han
E/EE

Specifications

DIN VDE 0627
DIN VDE 0110
DIN EN 61 984

Approvals



Inserts

Number of contacts 6, 10, 16, 24, 32 (2 x 16),
48 (2 x 24) + PE

Electrical data
acc. to DIN EN 61 984

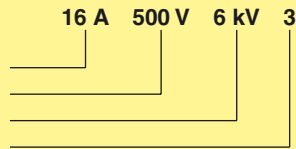

Working current
Working voltage
Rated impulse voltage
Pollution degree

- Pollution degree 2 also 16 A 400/690 V 6 kV 2

Working voltage
acc. to UL/CSA 600 V

Insulation resistance $\geq 10^{10} \Omega$
Material Polycarbonate
Limiting temperatures - 40 °C / +125 °C
Flammability acc. to UL 94 V 0
Mechanical working life
- Mating cycles ≥ 500

Contacts

Material copper alloy

Surface - hard-silver plated
Contact resistance 3 μm Ag
 $\leq 3 \text{ m}\Omega$

Cage-clamp terminal
- mm² 0.14 - 2.5 mm²
- AWG 26 - 14
Stripping length 7 - 9 mm

Hoods/Housings

Material die cast aluminium
Surface powder-coated
RAL 7037
Locking element Han-Easy Lock®
Hoods/housings seal NBR
Limiting temperatures - 40 °C / +125 °C

Degree of protection
acc. to DIN EN 60 529
for coupled connector IP 65

Further selection
of hoods/housings chapter 30 / chapter 31

Accessories

Cable clamps chapter 40
Coding of hoods/housings chapter 40
Label acc. to CSA-approval chapter 40
Han-Snap® chapter 11
Special insert fixing screws chapter 40

Current carrying capacity

The current carrying capacity is limited by maximum temperature of materials for inserts and contacts including terminals. The current capacity-curve is valid for continuous, not interrupted current-loaded contacts of connectors when simultaneous power on all contacts is given, without exceeding the maximum temperature.

Control and test procedures according to DIN IEC 60 512-3.

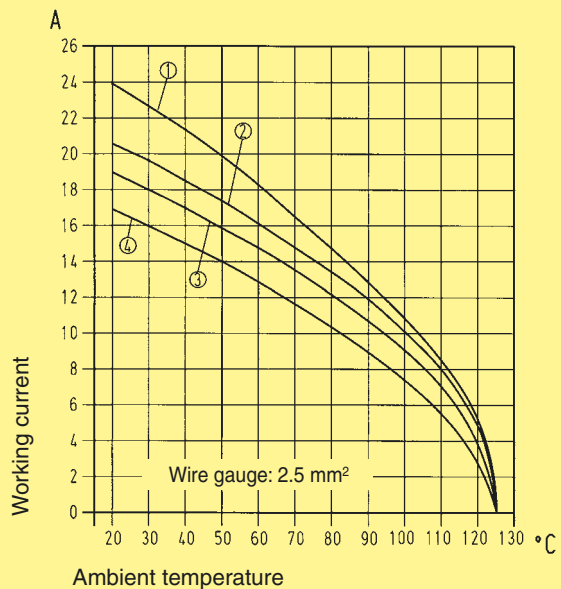
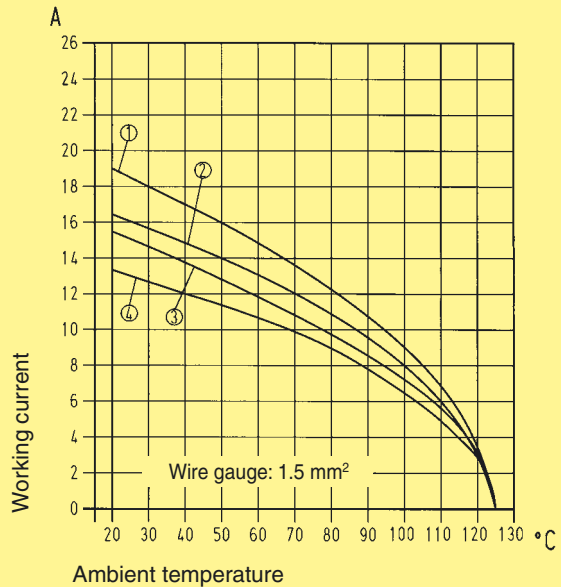

- ① Han® 6 ES
- ② Han® 10 ES
- ③ Han® 16 ES
- ④ Han® 24 ES

Features:

- 2 termination points per contact
- Termination: Cage-clamp
- Suitable for standard hoods/housings size B
- High construction hoods/housings are necessary
- No special tools necessary
- Bridges are made by using a simple screw driver
- Vibration resistant
- Ideal as motor connector as it offers the possibility to create star and delta bridges
- Testing is possible in the screwdriver aperture

Current carrying capacity

The current carrying capacity is limited by maximum temperature of materials for inserts and contacts including terminals. The current capacity-curve is valid for continuous, not interrupted current-loaded contacts of connectors when simultaneous power on all contacts is given, without exceeding the maximum temperature.

Control and test procedures according to DIN IEC 60 512-3.

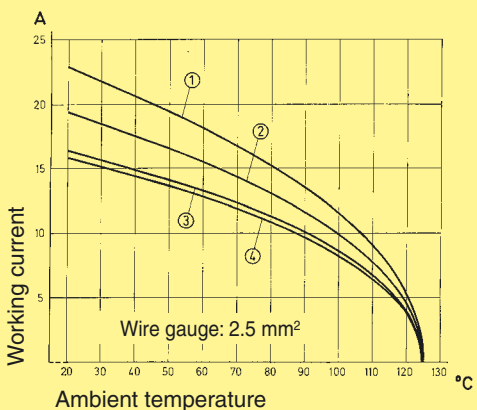
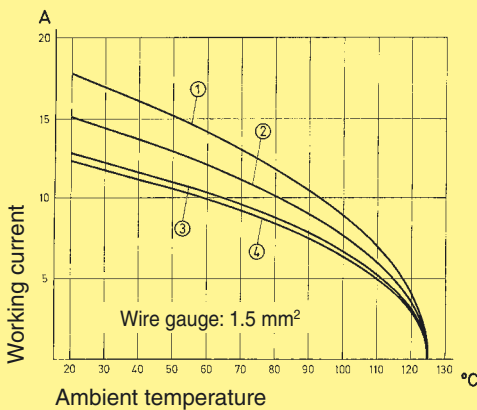

- ① Han[®] 6 ESS
- ② Han[®] 10 ESS
- ③ Han[®] 16 ESS
- ④ Han[®] 24 ESS

Specifications

DIN VDE 0627
DIN VDE 0110
DIN EN 61 984

Approvals

SEV, c us

Inserts

Number of contacts 6, 10, 16, 24, 32 (2 x 16),
48 (2 x 24) + PE

Electrical data
acc. to DIN EN 61 984

Working current
Working voltage
Rated impulse voltage
Pollution degree

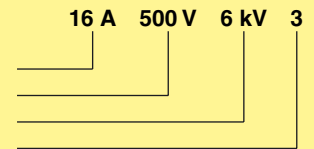

– Pollution degree 2 also 16 A 400/690 V 6 kV 2

Working voltage
acc. to UL/CSA 600 V

Test voltage U_{rms} 3 kV
Insulation resistance $\geq 10^{10} \Omega$
Material Polycarbonate
Limiting temperatures - 40 °C / +125 °C
Flammability acc. to UL 94 V 0
Mechanical working life
- Mating cycles ≥ 500

Contacts

Material copper alloy
Surface
- hard-silver plated 3 μm Ag
Contact resistance $\leq 3 \text{ m}\Omega$
Cage-clamp terminal
- mm² 0.14 - 2.5 mm²
- AWG 26 - 14
- Stripping length 9 - 11 mm

Hoods/Housings

Material die cast aluminium
Surface powder-coated RAL 7037
Locking element Han-Easy Lock[®]
Hoods/Housings seal NBR
Limiting temperatures - 40 °C / +125 °C
Degree of protection acc. to DIN EN 60 529 for coupled connector IP 65
Further selection of hoods/housings chapter 30 / chapter 31

Accessories

Cable clamps chapter 40
Coding of hoods/housings chapter 40
Label acc. to CSA-approval chapter 40
Han-Snap[®] chapter 11
Special insert fixing screws chapter 40

Number of contacts

6 +



Inserts

Han E / EE

Identification	Series	Part No.		Drawing	Dimensions in mm																				
		Male insert (M)	Female insert (F)																						
Screw terminal with wire protection 	Han E®	09 33 006 2601	09 33 006 2701	<p>1) Distance for contact max. 21 mm</p> <table border="1"> <thead> <tr> <th></th> <th>a</th> <th>b</th> <th>c</th> <th>d</th> </tr> </thead> <tbody> <tr> <td>Han E® screw</td> <td>18</td> <td>33</td> <td>18</td> <td>35</td> </tr> <tr> <td>Han® ES/Han E® crimp</td> <td>19</td> <td>34</td> <td>19</td> <td>36</td> </tr> <tr> <td>Han ESS</td> <td>34</td> <td>49</td> <td>32</td> <td>49</td> </tr> </tbody> </table> <p> Contact arrangement View from termination side </p> <p> Panel cut out for inserts for use without hoods/housings </p>		a	b	c	d	Han E® screw	18	33	18	35	Han® ES/Han E® crimp	19	34	19	36	Han ESS	34	49	32	49	
	a	b	c		d																				
Han E® screw	18	33	18		35																				
Han® ES/Han E® crimp	19	34	19		36																				
Han ESS	34	49	32		49																				
Cage-clamp terminal 	Han® ES	09 33 006 2616	09 33 006 2716																						
Cage-clamp terminal two terminals per contact 	Han® ESS	09 33 006 2672	09 33 006 2772																						
Crimp terminal Order contacts separately 	Han E®	09 33 006 2602	09 33 006 2702																						

Identification	Wire gauge (mm²)	Part No.		Drawing	Dimensions in mm
		Male contacts	Female contacts		
Crimp contacts Power contacts silver plated 	0.14-0.37 0.5 0.75 1.0 1.5 2.5 3 4	09 33 000 6127* 09 33 000 6121 09 33 000 6114 09 33 000 6105 09 33 000 6104 09 33 000 6102 09 33 000 6106 09 33 000 6107	09 33 000 6227* 09 33 000 6220 09 33 000 6214 09 33 000 6205 09 33 000 6204 09 33 000 6202 09 33 000 6206 09 33 000 6207		
gold plated 	0.14-0.37 0.5 0.75 1.0 1.5 2.5 4.0	09 33 000 6117* 09 33 000 6122 09 33 000 6115 09 33 000 6118 09 33 000 6116 09 33 000 6123 09 33 000 6119	09 33 000 6217* 09 33 000 6222 09 33 000 6215 09 33 000 6218 09 33 000 6216 09 33 000 6223 09 33 000 6221		
Relay contact silver plated 	0.75-1 1.5 2.5	09 33 000 6109 09 33 000 6110 09 33 000 6111			

Identification	Wire gauge	Stripping length	
no groove	0.14-0.37 mm²	AWG 26-22	7,5 mm
no groove	0.5 mm²	AWG 20	7,5 mm
1 groove*	0.75 mm²	AWG 18	7,5 mm
1 groove	1 mm²	AWG 18	7,5 mm
2 grooves	1.5 mm²	AWG 16	7,5 mm
3 grooves	2.5 mm²	AWG 14	7,5 mm
wide groove	3.0 mm²	AWG 12	7,5 mm
no groove	4 mm²	AWG 12	7,5 mm

* on the back crimp collar

Identification	Part No.
Coding Pin 	09 33 000 9954

Use of the coding pin prevents incorrect mating to other connectors of the same type.

The male pin should be omitted from the opposing cavity in the male insert.

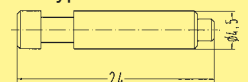

03
14

* only to be used with BUCHANAN crimping tool 09 99 000 0001 and adjustment gauge 09 99 000 0203

Stock items in bold type

Number of contacts

10 +



Inserts

Identification	Series	Part No.		Drawing	Dimensions in mm
		Male insert (M)	Female insert (F)		
Crimp terminal Order contacts separately	Han® EE	09 32 010 3001	09 32 010 3101	<p>1) Distance for contact max. 21 mm</p> <p> Contact arrangement View from termination side </p> <p> </p>	









Identification	Wire gauge (mm²)	Part No.		Drawing	Dimensions in mm																											
		Male contacts	Female contacts																													
Crimp contacts Power contacts silver plated	0.14-0.37 0.5 0.75 1.0 1.5 2.5 3 4	09 33 000 6127* 09 33 000 6121 09 33 000 6114 09 33 000 6105 09 33 000 6104 09 33 000 6102 09 33 000 6106 09 33 000 6107	09 33 000 6227* 09 33 000 6220 09 33 000 6214 09 33 000 6205 09 33 000 6204 09 33 000 6206 09 33 000 6207	<p>Operation contact Identification</p> <p>Relay contact</p> <p>Crimp contact identification</p>																												
gold plated	0.14-0.37 0.5 0.75 1.0 1.5 2.5 4.0	09 33 000 6117* 09 33 000 6122 09 33 000 6115 09 33 000 6118 09 33 000 6116 09 33 000 6123 09 33 000 6119	09 33 000 6217* 09 33 000 6222 09 33 000 6215 09 33 000 6218 09 33 000 6216 09 33 000 6223 09 33 000 6221	<table border="1"> <thead> <tr> <th>Identification</th> <th>Wire gauge</th> <th>Stripping length</th> </tr> </thead> <tbody> <tr> <td>no groove</td> <td>0.14-0.37 mm²</td> <td>AWG 26-22</td> </tr> <tr> <td>no groove</td> <td>0.5 mm²</td> <td>AWG 20</td> </tr> <tr> <td>1 groove*</td> <td>0.75 mm²</td> <td>AWG 18</td> </tr> <tr> <td>1 groove</td> <td>1 mm²</td> <td>AWG 18</td> </tr> <tr> <td>2 grooves</td> <td>1.5 mm²</td> <td>AWG 16</td> </tr> <tr> <td>3 grooves</td> <td>2.5 mm²</td> <td>AWG 14</td> </tr> <tr> <td>wide groove</td> <td>3.0 mm²</td> <td>AWG 12</td> </tr> <tr> <td>no groove</td> <td>4 mm²</td> <td>AWG 12</td> </tr> </tbody> </table> <p>* on the back crimp collar</p>	Identification	Wire gauge	Stripping length	no groove	0.14-0.37 mm²	AWG 26-22	no groove	0.5 mm²	AWG 20	1 groove*	0.75 mm²	AWG 18	1 groove	1 mm²	AWG 18	2 grooves	1.5 mm²	AWG 16	3 grooves	2.5 mm²	AWG 14	wide groove	3.0 mm²	AWG 12	no groove	4 mm²	AWG 12	
Identification	Wire gauge	Stripping length																														
no groove	0.14-0.37 mm²	AWG 26-22																														
no groove	0.5 mm²	AWG 20																														
1 groove*	0.75 mm²	AWG 18																														
1 groove	1 mm²	AWG 18																														
2 grooves	1.5 mm²	AWG 16																														
3 grooves	2.5 mm²	AWG 14																														
wide groove	3.0 mm²	AWG 12																														
no groove	4 mm²	AWG 12																														

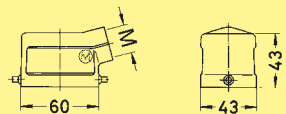
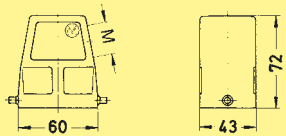

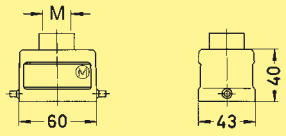
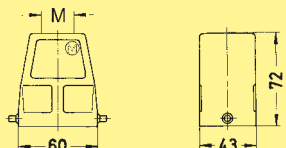

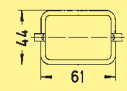
FOC contacts for 1 mm plastic fibre		20 10 001 3311	20 10 001 3321	
---	--	----------------	----------------	--

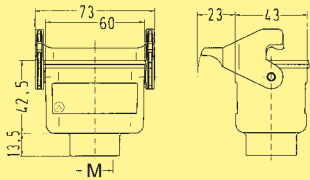
Coding Pin 		09 33 000 9954		Use of the coding pin prevents incorrect mating to other connectors of the same type. The male pin should be omitted from the opposing cavity in the male insert.	
-----------------------	--	----------------	--	--	--

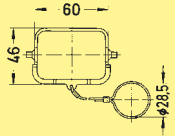
* only to be used with BUCHANAN crimping tool 09 99 000 0001 and adjustment gauge 09 99 000 0203

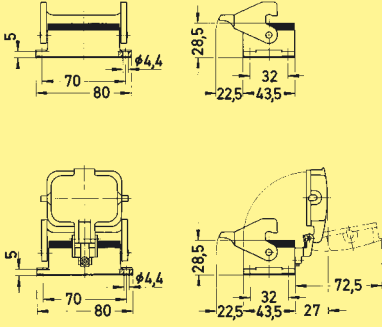
Han
E / EE

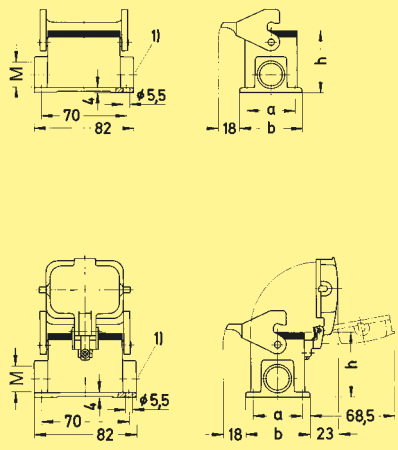
Identification	Part No.		M	Drawing	Dimensions in mm	
	Low construction	High construction				
Hoods side-entry 	19 30 006 1540 19 30 006 1541		20		43	
			25			
		19 30 006 0546 19 30 006 0547		25		43
				32		
	Hoods top-entry 	19 30 006 1440		20		43
				25		
		19 30 006 0446 19 30 006 0447		25		43
				32		
Protection covers for hoods metal 		09 30 006 5401				
				09 30 006 5423		
Hoods cable to cable 	19 30 006 1750	19 30 006 0756	20		43	
			25			
Protection cover for cable to cable hood metal 	09 30 006 5427					

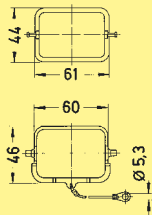
Identification	Part No.			Drawing	Dimensions in mm													
	Low construction	High construction	M															
Housings bulkhead mounting 	09 30 006 0301 with thermo-plastic cover 09 30 006 0302 with metal cover 09 30 006 0318		— — —	Panel cut out 48 x 35 mm 														
	Housings surface mounting 	19 30 006 1250 19 30 006 1290 with thermo-plastic cover 19 30 006 1255 19 30 006 1295 with metal cover 19 30 006 2255 19 30 006 2295	19 30 006 0291 19 30 006 0292 with thermo-plastic cover 19 30 006 0296 19 30 006 0297 with metal cover 19 30 006 7296	1 x 20 2 x 20 2 x 25 2 x 32 1 x 20 2 x 20 2 x 25 2 x 32 1 x 20 2 x 20 2 x 25	 <p>1) Blind way for one cable entry</p> <table border="1"> <thead> <tr> <th></th> <th>a</th> <th>b</th> <th>h</th> </tr> </thead> <tbody> <tr> <td>Low construction</td> <td>40</td> <td>52</td> <td>51.5</td> </tr> <tr> <td>High construction</td> <td>45</td> <td>57</td> <td>74</td> </tr> </tbody> </table>		a	b	h	Low construction	40	52	51.5	High construction	45	57	74	
			a	b	h													
Low construction		40	52	51.5														
High construction	45	57	74															
Protection covers metal 	09 30 006 5404 09 30 006 5425																	

Han
E/EE

Housings

Number of contacts

10 +



Inserts

Han E/EE

Identification	Series	Part No.		Drawing	Dimensions in mm																				
		Male insert (M)	Female insert (F)																						
Screw terminal with wire protection 	Han E®	09 33 010 2601	09 33 010 2701	<p>1) Distance for contact max. 21 mm</p> <table border="1"> <tr> <td></td> <td>a</td> <td>b</td> <td>c</td> <td>d</td> </tr> <tr> <td>Han E® screw</td> <td>18</td> <td>33</td> <td>18</td> <td>35</td> </tr> <tr> <td>Han® ES/Han E® crimp</td> <td>19</td> <td>34</td> <td>19</td> <td>36</td> </tr> <tr> <td>Han ESS</td> <td>34</td> <td>49</td> <td>32</td> <td>49</td> </tr> </table>		a	b	c	d	Han E® screw	18	33	18	35	Han® ES/Han E® crimp	19	34	19	36	Han ESS	34	49	32	49	
	a	b	c		d																				
Han E® screw	18	33	18		35																				
Han® ES/Han E® crimp	19	34	19		36																				
Han ESS	34	49	32	49																					
Cage-clamp terminal 	Han® ES	09 33 010 2616	09 33 010 2716																						
Cage-clamp terminal two terminals per contact 	Han® ESS	09 33 010 2672	09 33 010 2772																						
Crimp terminal Order contacts separately 	Han E®	09 33 010 2602	09 33 010 2702	Contact arrangement View from termination side 																					

Identification	Wire gauge (mm²)	Part No.		Drawing	Dimensions in mm																																			
		Male contacts	Female contacts																																					
Crimp contacts Power contacts silver plated 	0.14-0.37 0.5 0.75 1.0 1.5 2.5 3 4	09 33 000 6127* 09 33 000 6121 09 33 000 6114 09 33 000 6105 09 33 000 6104 09 33 000 6102 09 33 000 6106 09 33 000 6107	09 33 000 6227* 09 33 000 6220 09 33 000 6214 09 33 000 6205 09 33 000 6204 09 33 000 6202 09 33 000 6206 09 33 000 6207		Operating contact Identification Relay contact																																			
gold plated 	0.14-0.37 0.5 0.75 1.0 1.5 2.5 4.0	09 33 000 6117* 09 33 000 6122 09 33 000 6115 09 33 000 6118 09 33 000 6116 09 33 000 6123 09 33 000 6119	09 33 000 6217* 09 33 000 6222 09 33 000 6215 09 33 000 6218 09 33 000 6216 09 33 000 6223 09 33 000 6221																																					
Relay contact silver plated 	0.75-1 1.5 2.5	09 33 000 6109 09 33 000 6110 09 33 000 6111		Crimp contact identification <table border="1"> <thead> <tr> <th>Identification</th> <th>Wire gauge</th> <th>AWG</th> <th>Stripping length</th> </tr> </thead> <tbody> <tr> <td>no groove</td> <td>0.14-0.37 mm²</td> <td>AWG 26-22</td> <td>7,5 mm</td> </tr> <tr> <td>no groove</td> <td>0.5 mm²</td> <td>AWG 20</td> <td>7,5 mm</td> </tr> <tr> <td>1 groove*</td> <td>0.75 mm²</td> <td>AWG 18</td> <td>7,5 mm</td> </tr> <tr> <td>1 groove</td> <td>1 mm²</td> <td>AWG 18</td> <td>7,5 mm</td> </tr> <tr> <td>2 grooves</td> <td>1.5 mm²</td> <td>AWG 16</td> <td>7,5 mm</td> </tr> <tr> <td>3 grooves</td> <td>2.5 mm²</td> <td>AWG 14</td> <td>7,5 mm</td> </tr> <tr> <td>wide groove</td> <td>3.0 mm²</td> <td>AWG 12</td> <td>7,5 mm</td> </tr> <tr> <td>no groove</td> <td>4 mm²</td> <td>AWG 12</td> <td>7,5 mm</td> </tr> </tbody> </table>	Identification	Wire gauge	AWG	Stripping length	no groove	0.14-0.37 mm²	AWG 26-22	7,5 mm	no groove	0.5 mm²	AWG 20	7,5 mm	1 groove*	0.75 mm²	AWG 18	7,5 mm	1 groove	1 mm²	AWG 18	7,5 mm	2 grooves	1.5 mm²	AWG 16	7,5 mm	3 grooves	2.5 mm²	AWG 14	7,5 mm	wide groove	3.0 mm²	AWG 12	7,5 mm	no groove	4 mm²	AWG 12	7,5 mm
Identification	Wire gauge	AWG	Stripping length																																					
no groove	0.14-0.37 mm²	AWG 26-22	7,5 mm																																					
no groove	0.5 mm²	AWG 20	7,5 mm																																					
1 groove*	0.75 mm²	AWG 18	7,5 mm																																					
1 groove	1 mm²	AWG 18	7,5 mm																																					
2 grooves	1.5 mm²	AWG 16	7,5 mm																																					
3 grooves	2.5 mm²	AWG 14	7,5 mm																																					
wide groove	3.0 mm²	AWG 12	7,5 mm																																					
no groove	4 mm²	AWG 12	7,5 mm																																					

Coding Pin 		09 33 000 9954	Use of the coding pin prevents incorrect mating to other connectors of the same type. The male pin should be omitted from the opposing cavity in the male insert.
----------------	--	-----------------------	--

03
18

* only to be used with BUCHANAN crimping tool 09 99 000 0001 and adjustment gauge 09 99 000 0203

Stock items in bold type

Number of contacts

18 +



Inserts

Identification	Series	Part No.		Drawing	Dimensions in mm
		Male insert (M)	Female insert (F)		
<p>Crimp terminal Order contacts separately</p>	Han® EE	09 32 018 3001	09 32 018 3101	<p>1) Distance for contact max. 21 mm</p> <p>View from termination side</p> <p>Panel cut out for inserts for use without hoods/housings</p>	









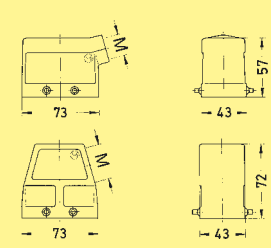

Identification	Wire gauge (mm²)	Part No.		Drawing	Dimensions in mm																											
		Male contacts	Female contacts																													
<p>Crimp contacts</p> <p>Power contacts</p> <p>silver plated </p> <p>gold plated </p>	<p>0.14-0.37</p> <p>0.5</p> <p>0.75</p> <p>1.0</p> <p>1.5</p> <p>2.5</p> <p>3</p> <p>4</p> <p>0.14-0.37</p> <p>0.5</p> <p>0.75</p> <p>1.0</p> <p>1.5</p> <p>2.5</p> <p>4.0</p>	<p>09 33 000 6127*</p> <p>09 33 000 6121</p> <p>09 33 000 6114</p> <p>09 33 000 6105</p> <p>09 33 000 6104</p> <p>09 33 000 6102</p> <p>09 33 000 6106</p> <p>09 33 000 6107</p>	<p>09 33 000 6227*</p> <p>09 33 000 6220</p> <p>09 33 000 6214</p> <p>09 33 000 6205</p> <p>09 33 000 6204</p> <p>09 33 000 6202</p> <p>09 33 000 6206</p> <p>09 33 000 6207</p>	<p>Crimp contact identification</p> <table border="1"> <thead> <tr> <th>Identification</th> <th>Wire gauge</th> <th>Stripping length</th> </tr> </thead> <tbody> <tr> <td>no groove</td> <td>0.14-0.37 mm²</td> <td>AWG 26-22</td> </tr> <tr> <td>no groove</td> <td>0.5 mm²</td> <td>AWG 20</td> </tr> <tr> <td>1 groove*</td> <td>0.75 mm²</td> <td>AWG 18</td> </tr> <tr> <td>1 groove</td> <td>1 mm²</td> <td>AWG 18</td> </tr> <tr> <td>2 grooves</td> <td>1.5 mm²</td> <td>AWG 16</td> </tr> <tr> <td>3 grooves</td> <td>2.5 mm²</td> <td>AWG 14</td> </tr> <tr> <td>wide groove</td> <td>3.0 mm²</td> <td>AWG 12</td> </tr> <tr> <td>no groove</td> <td>4 mm²</td> <td>AWG 12</td> </tr> </tbody> </table> <p>* on the back crimp collar</p>	Identification	Wire gauge	Stripping length	no groove	0.14-0.37 mm²	AWG 26-22	no groove	0.5 mm²	AWG 20	1 groove*	0.75 mm²	AWG 18	1 groove	1 mm²	AWG 18	2 grooves	1.5 mm²	AWG 16	3 grooves	2.5 mm²	AWG 14	wide groove	3.0 mm²	AWG 12	no groove	4 mm²	AWG 12	
Identification	Wire gauge	Stripping length																														
no groove	0.14-0.37 mm²	AWG 26-22																														
no groove	0.5 mm²	AWG 20																														
1 groove*	0.75 mm²	AWG 18																														
1 groove	1 mm²	AWG 18																														
2 grooves	1.5 mm²	AWG 16																														
3 grooves	2.5 mm²	AWG 14																														
wide groove	3.0 mm²	AWG 12																														
no groove	4 mm²	AWG 12																														

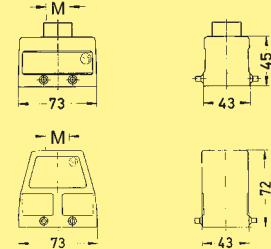

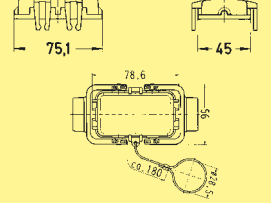





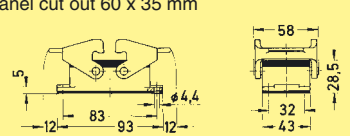
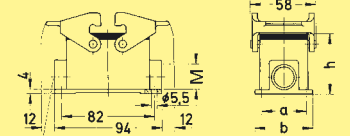
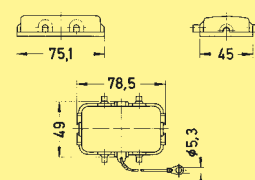
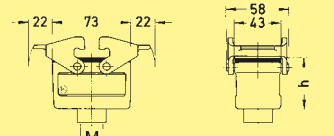
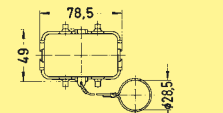

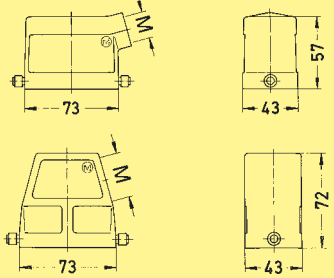
<p>FOC contacts for 1 mm plastic fibre</p>		20 10 001 3311	20 10 001 3321		
---	--	-----------------------	-----------------------	--	--

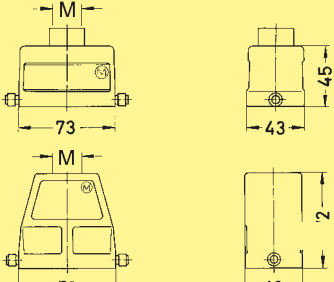
<p>Coding Pin</p>		09 33 000 9954		<p>Use of the coding pin prevents incorrect mating to other connectors of the same type.</p> <p>The male pin should be omitted from the opposing cavity in the male insert.</p>	
--------------------------	--	-----------------------	--	---	--

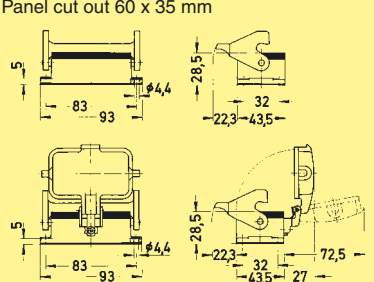
* only to be used with BUCHANAN crimping tool 09 99 000 0001 and adjustment gauge 09 99 000 0203

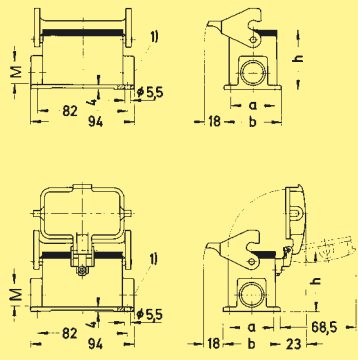
Han
E / EE

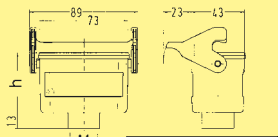
Identification	Part No.			Drawing	Dimensions in mm												
	Low construction	High construction	M														
Hoods side-entry 	19 30 010 1520 19 30 010 1521	19 30 010 0527	20 25 32														
	Hoods top-entry 		19 30 010 1420 19 30 010 1421			20 25 32											
			Protection covers for hoods thermoplastic/metal 			09 30 010 5401 09 30 010 5423											
Housings bulkhead mounting  surface mounting  1 side-entry 2 side-entries Protection covers for housings bulkhead/surface mounting thermoplastic/metal  Hoods cable to cable  Protection cover for hoods cable to cable metal 	09 30 010 0301		—	Panel cut out 60 x 35 mm 													
	19 30 010 1230 19 30 010 1231	19 30 010 0231	20 25		Blind way for one cable entry <table border="1"> <thead> <tr> <th></th> <th>a</th> <th>b</th> <th>h</th> </tr> </thead> <tbody> <tr> <td>Low construction</td> <td>40</td> <td>52</td> <td>54</td> </tr> <tr> <td>High construction</td> <td>45</td> <td>57</td> <td>74</td> </tr> </tbody> </table>		a	b	h	Low construction	40	52	54	High construction	45	57	74
			a			b	h										
	Low construction	40	52	54													
	High construction	45	57	74													
	19 30 010 1270	19 30 010 0271 19 30 010 0272	20 25 32														
09 30 010 5407 09 30 010 5425																	
19 30 010 1730	19 30 010 0736 19 30 010 0737	20 25 32		<table border="1"> <thead> <tr> <th></th> <th>h</th> </tr> </thead> <tbody> <tr> <td>Low construction</td> <td>47.5</td> </tr> <tr> <td>High construction</td> <td>74.5</td> </tr> </tbody> </table>		h	Low construction	47.5	High construction	74.5							
		h															
Low construction	47.5																
High construction	74.5																
09 30 010 5427																	

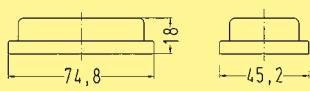
Identification	Part No.			Drawing	Dimensions in mm	
	Low construction	High construction	M			
Hoods	Hoods side-entry 	19 30 010 1540		20		
		19 30 010 1541		25		
			19 30 010 0547	32		
	Hoods top-entry 	19 30 010 1440		20		
		19 30 010 1441		25		
			19 30 010 0447	32		
Housings	Housings bulkhead mounting 	09 30 010 0305		—		
		with thermo-plastic cover 09 30 010 0303		—		
		with metal cover 09 30 010 0318		—		
	Housings surface mounting 	1 side-entry 19 30 010 1250		20		
		2 side-entries 19 30 010 1290		20		
			19 30 010 0291			25
			19 30 010 0292			32
		1 side-entry 19 30 010 1255	with thermo-plastic cover	with thermo-plastic cover		20
		2 side-entries 19 30 010 1295	with thermo-plastic cover	with thermo-plastic cover		20
		19 30 010 0296	19 30 010 0297	25		
	19 30 010 2295	with metal cover	20			
		with metal cover	25			
		19 30 010 7296	20			
			25			
Hoods cable to cable 	19 30 010 1750		20			
		19 30 010 0756	25			
		19 30 010 0757	32			
Dust protection cover 	09 30 010 5406					

Han
E/EE

1) Blind way for one cable entry

	a	b	h
Low construction	40	52	54
High construction	45	57	74

	h
Low construction	47.5
High construction	74.5

Number of contacts

16 +



Inserts

Han E/EE

Identification	Series	Part No.		Drawing	Dimensions in mm																				
		Male insert (M)	Female insert (F)																						
Screw terminal with wire protection 	Han E®	09 33 016 2601	09 33 016 2701	<p>1) Distance for contact max. 21 mm</p> <table border="1"> <thead> <tr> <th></th> <th>a</th> <th>b</th> <th>c</th> <th>d</th> </tr> </thead> <tbody> <tr> <td>Han E® screw</td> <td>18</td> <td>33</td> <td>18</td> <td>35</td> </tr> <tr> <td>Han® ES/Han E® crimp</td> <td>19</td> <td>34</td> <td>19</td> <td>36</td> </tr> <tr> <td>Han ESS</td> <td>34</td> <td>49</td> <td>32</td> <td>49</td> </tr> </tbody> </table>		a	b	c	d	Han E® screw	18	33	18	35	Han® ES/Han E® crimp	19	34	19	36	Han ESS	34	49	32	49	
	a	b	c		d																				
Han E® screw	18	33	18		35																				
Han® ES/Han E® crimp	19	34	19		36																				
Han ESS	34	49	32	49																					
Cage-clamp terminal 	Han® ES	09 33 016 2616	09 33 016 2716																						
Cage-clamp terminal two terminals per contact 	Han® ESS	09 33 016 2672	09 33 016 2772																						
Crimp terminal Order contacts separately 	Han E®	09 33 016 2602	09 33 016 2702	Contact arrangement View from termination side <p>Panel cut out for inserts for use without hoods/housings </p>																					

Identification	Wire gauge (mm²)	Part No.		Drawing	Dimensions in mm																																			
		Male contacts	Female contacts																																					
Crimp contacts Power contacts silver plated 	0.14-0.37 0.5 0.75 1.0 1.5 2.5 3 4	09 33 000 6127* 09 33 000 6121 09 33 000 6114 09 33 000 6105 09 33 000 6104 09 33 000 6102 09 33 000 6106 09 33 000 6107	09 33 000 6227* 09 33 000 6220 09 33 000 6214 09 33 000 6205 09 33 000 6204 09 33 000 6202 09 33 000 6206 09 33 000 6207		Operating contact Identification Relay contact																																			
gold plated 	0.14-0.37 0.5 0.75 1.0 1.5 2.5 4.0	09 33 000 6117* 09 33 000 6122 09 33 000 6115 09 33 000 6118 09 33 000 6116 09 33 000 6123 09 33 000 6119	09 33 000 6217* 09 33 000 6222 09 33 000 6215 09 33 000 6218 09 33 000 6216 09 33 000 6223 09 33 000 6221	Crimp contact identification <table border="1"> <thead> <tr> <th>Identification</th> <th>Wire gauge</th> <th>AWG</th> <th>Stripping length</th> </tr> </thead> <tbody> <tr> <td>no groove</td> <td>0.14-0.37 mm²</td> <td>AWG 26-22</td> <td>7,5 mm</td> </tr> <tr> <td>no groove</td> <td>0.5 mm²</td> <td>AWG 20</td> <td>7,5 mm</td> </tr> <tr> <td>1 groove*</td> <td>0.75 mm²</td> <td>AWG 18</td> <td>7,5 mm</td> </tr> <tr> <td>1 groove</td> <td>1 mm²</td> <td>AWG 18</td> <td>7,5 mm</td> </tr> <tr> <td>2 grooves</td> <td>1.5 mm²</td> <td>AWG 16</td> <td>7,5 mm</td> </tr> <tr> <td>3 grooves</td> <td>2.5 mm²</td> <td>AWG 14</td> <td>7,5 mm</td> </tr> <tr> <td>wide groove</td> <td>3.0 mm²</td> <td>AWG 12</td> <td>7,5 mm</td> </tr> <tr> <td>no groove</td> <td>4 mm²</td> <td>AWG 12</td> <td>7,5 mm</td> </tr> </tbody> </table>	Identification	Wire gauge	AWG	Stripping length	no groove	0.14-0.37 mm²	AWG 26-22	7,5 mm	no groove	0.5 mm²	AWG 20	7,5 mm	1 groove*	0.75 mm²	AWG 18	7,5 mm	1 groove	1 mm²	AWG 18	7,5 mm	2 grooves	1.5 mm²	AWG 16	7,5 mm	3 grooves	2.5 mm²	AWG 14	7,5 mm	wide groove	3.0 mm²	AWG 12	7,5 mm	no groove	4 mm²	AWG 12	7,5 mm
Identification	Wire gauge	AWG	Stripping length																																					
no groove	0.14-0.37 mm²	AWG 26-22	7,5 mm																																					
no groove	0.5 mm²	AWG 20	7,5 mm																																					
1 groove*	0.75 mm²	AWG 18	7,5 mm																																					
1 groove	1 mm²	AWG 18	7,5 mm																																					
2 grooves	1.5 mm²	AWG 16	7,5 mm																																					
3 grooves	2.5 mm²	AWG 14	7,5 mm																																					
wide groove	3.0 mm²	AWG 12	7,5 mm																																					
no groove	4 mm²	AWG 12	7,5 mm																																					
Relay contact silver plated 	0.75-1 1.5 2.5	09 33 000 6109 09 33 000 6110 09 33 000 6111																																						

Coding Pin 		09 33 000 9954	Use of the coding pin prevents incorrect mating to other connectors of the same type. The male pin should be omitted from the opposing cavity in the male insert.
----------------	--	-----------------------	--

03
22

* only to be used with BUCHANAN crimping tool 09 99 000 0001 and adjustment gauge 09 99 000 0203

Stock items in bold type

Number of contacts

32 +



Inserts

Identification	Series	Part No.		Drawing	Dimensions in mm
		Male insert (M)	Female insert (F)		
<p>Crimp terminal Order contacts separately</p>	Han® EE	09 32 032 3001	09 32 032 3101	<p>¹⁾ Distance for contact max. 21 mm</p> <p>Contact arrangement View from termination side</p> <p>Panel cut out for inserts for use without hoods/housings</p>	

Identification	Wire gauge (mm ²)	Part No.		Drawing	Dimensions in mm																																					
		Male contacts	Female contacts																																							
<p>Crimp contacts Power contacts</p>	0.14-0.37	09 33 000 6127*	09 33 000 6227*																																							
<p>silver plated </p>	0.5	09 33 000 6121	09 33 000 6220	<p>Crimp contact identification</p> <table border="1"> <thead> <tr> <th>Identification</th> <th>Wire gauge</th> <th>Stripping length</th> </tr> </thead> <tbody> <tr> <td>no groove</td> <td>0.14-0.37 mm²</td> <td>AWG 26-22</td> <td>7.5 mm</td> </tr> <tr> <td>no groove</td> <td>0.5 mm²</td> <td>AWG 20</td> <td>7.5 mm</td> </tr> <tr> <td>1 groove*</td> <td>0.75 mm²</td> <td>AWG 18</td> <td>7.5 mm</td> </tr> <tr> <td>1 groove</td> <td>1 mm²</td> <td>AWG 18</td> <td>7.5 mm</td> </tr> <tr> <td>2 grooves</td> <td>1.5 mm²</td> <td>AWG 16</td> <td>7.5 mm</td> </tr> <tr> <td>3 grooves</td> <td>2.5 mm²</td> <td>AWG 14</td> <td>7.5 mm</td> </tr> <tr> <td>wide groove</td> <td>3.0 mm²</td> <td>AWG 12</td> <td>7.5 mm</td> </tr> <tr> <td>no groove</td> <td>4 mm²</td> <td>AWG 12</td> <td>7.5 mm</td> </tr> </tbody> </table> <p>* on the back crimp collar</p>	Identification	Wire gauge	Stripping length	no groove	0.14-0.37 mm ²	AWG 26-22	7.5 mm	no groove	0.5 mm ²	AWG 20	7.5 mm	1 groove*	0.75 mm ²	AWG 18	7.5 mm	1 groove	1 mm ²	AWG 18	7.5 mm	2 grooves	1.5 mm ²	AWG 16	7.5 mm	3 grooves	2.5 mm ²	AWG 14	7.5 mm	wide groove	3.0 mm ²	AWG 12	7.5 mm	no groove	4 mm ²	AWG 12	7.5 mm	0.75	09 33 000 6114	09 33 000 6214
Identification	Wire gauge	Stripping length																																								
no groove	0.14-0.37 mm ²	AWG 26-22	7.5 mm																																							
no groove	0.5 mm ²	AWG 20	7.5 mm																																							
1 groove*	0.75 mm ²	AWG 18	7.5 mm																																							
1 groove	1 mm ²	AWG 18	7.5 mm																																							
2 grooves	1.5 mm ²	AWG 16	7.5 mm																																							
3 grooves	2.5 mm ²	AWG 14	7.5 mm																																							
wide groove	3.0 mm ²	AWG 12	7.5 mm																																							
no groove	4 mm ²	AWG 12	7.5 mm																																							
	1.0	09 33 000 6105	09 33 000 6205																																							
	1.5	09 33 000 6104	09 33 000 6204																																							
	2.5	09 33 000 6102	09 33 000 6202																																							
	3	09 33 000 6106	09 33 000 6206																																							
	4	09 33 000 6107	09 33 000 6207																																							
<p>gold plated </p>	0.14-0.37	09 33 000 6117*	09 33 000 6217*																																							
	0.5	09 33 000 6122	09 33 000 6222																																							
	0.75	09 33 000 6115	09 33 000 6215																																							
	1.0	09 33 000 6118	09 33 000 6218																																							
	1.5	09 33 000 6116	09 33 000 6216																																							
	2.5	09 33 000 6123	09 33 000 6223																																							
	4.0	09 33 000 6119	09 33 000 6221																																							

<p>FOC contacts for 1 mm plastic fibre</p>		20 10 001 3311	20 10 001 3321	
---	--	-----------------------	-----------------------	--

<p>Coding Pin</p>		09 33 000 9954	<p>Use of the coding pin prevents incorrect mating to other connectors of the same type.</p> <p>The male pin should be omitted from the opposing cavity in the male insert.</p>
--------------------------	--	-----------------------	---

* only to be used with BUCHANAN crimping tool 09 99 000 0001 and adjustment gauge 09 99 000 0203

Han
E/EE

Identification	Part No.			Drawing	Dimensions in mm
	Low construction	High construction	M		
Hoods	Hoods side-entry 	19 30 016 1521 19 30 016 1522		25 32	
			19 30 016 0527 19 30 016 0528	32 40	
	Hoods top-entry 	19 30 016 1421 19 30 016 1422		25 32	
			19 30 016 0427 19 30 016 0428	32 40	
	Protection covers for housings thermoplastic/metal 	09 30 016 5401 09 30 016 5422			
Housings	Housing bulkhead mounting 	09 30 016 0301		—	Panel cut out 82 x 35 mm
	Housings surface mounting	1 side-entry 19 30 016 1231	19 30 016 0232	25 32	
		2 side-entries 19 30 016 1271	19 30 016 0271 19 30 016 0272 19 30 016 0273	25 32 40	
	Protection covers for housings bulkhead mounting thermoplastic/metal 	09 30 016 5405 09 30 016 5425			
	Hoods cable to cable 	19 30 016 1731	19 30 016 0736 19 30 016 0737	25 32	
	Protection cover for hoods cable to cable metal 	09 30 016 5426			

Identification	Part No.			Drawing	Dimensions in mm	
	Low construction	High construction	M			
Hoods	Hoods side-entry 	19 30 016 1541 19 30 016 1542		25 32		
			19 30 016 0547 19 30 016 0548	32 40		
	Hoods top-entry 	19 30 016 1441 19 30 016 1442		25 32		
			19 30 016 0447 19 30 016 0448	32 40		
Housings	Housings bulkhead mounting 	09 30 016 0307		—	Panel cut out 82 x 35 mm 	
		with thermo-plastic cover 09 30 016 0306		—		
		with metal cover 09 30 016 0318		—		
	Housings surface mounting 	1 side-entry 19 30 016 1251		19 30 016 0252	25 32	
		2 side-entries 19 30 016 1291		19 30 016 0291 19 30 016 0292	25 32	
		1 side-entry 19 30 016 1256			25	
		2 side-entries 19 30 016 1296		with thermo-plastic cover 19 30 016 0297	25 32	
		2 side-entries 19 30 016 2296		with thermo-plastic cover 19 30 016 0297 with metal cover 19 30 016 7297	25 32	
	Hoods cable to cable 	19 30 016 1751		19 30 016 0757	25 32	
Dust protection cover 	09 30 016 5406					

Han
E/EE

1) Blind way for one cable entry

	h
Low construction	56
High construction	81

	h
Low construction	47.5
High construction	78.5

Number of contacts

24 +

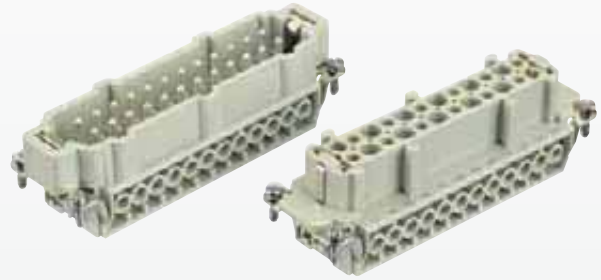

Inserts

Han E / EE

Identification	Series	Part No.		Drawing	Dimensions in mm																				
		Male insert (M)	Female insert (F)																						
Screw terminal with wire protection 	Han E®	09 33 024 2601	09 33 024 2701	<p>1) Distance for contact max. 21 mm</p> <table border="1"> <thead> <tr> <th></th> <th>a</th> <th>b</th> <th>c</th> <th>d</th> </tr> </thead> <tbody> <tr> <td>Han E® screw</td> <td>18</td> <td>33</td> <td>18</td> <td>35</td> </tr> <tr> <td>Han® ES/Han E® crimp</td> <td>19</td> <td>34</td> <td>19</td> <td>36</td> </tr> <tr> <td>Han ESS</td> <td>34</td> <td>49</td> <td>32</td> <td>49</td> </tr> </tbody> </table>		a	b	c	d	Han E® screw	18	33	18	35	Han® ES/Han E® crimp	19	34	19	36	Han ESS	34	49	32	49	
	a	b	c		d																				
Han E® screw	18	33	18		35																				
Han® ES/Han E® crimp	19	34	19		36																				
Han ESS	34	49	32	49																					
Cage-clamp terminal 	Han® ES	09 33 024 2616	09 33 024 2716																						
Cage-clamp terminal two terminals per contact 	Han® ESS	09 33 024 2672	09 33 024 2772																						
Crimp terminal Order contacts separately 	Han E®	09 33 024 2602	09 33 024 2702	Contact arrangement View from termination side <p>Panel cut out for inserts for use without hoods/housings </p>																					

Identification	Wire gauge (mm²)	Part No.		Drawing	Dimensions in mm																																				
		Male contacts	Female contacts																																						
Crimp contacts Power contacts silver plated 	0.14-0.37	09 33 000 6127*	09 33 000 6227*																																						
	0.5	09 33 000 6121	09 33 000 6220																																						
	0.75	09 33 000 6114	09 33 000 6214																																						
	1.0	09 33 000 6105	09 33 000 6205																																						
	1.5	09 33 000 6104	09 33 000 6204																																						
	2.5	09 33 000 6102	09 33 000 6202																																						
	3	09 33 000 6106	09 33 000 6206																																						
gold plated 	0.14-0.37	09 33 000 6117*	09 33 000 6217*	Crimp contact identification <table border="1"> <thead> <tr> <th>Identification</th> <th>Wire gauge</th> <th>AWG</th> <th>Stripping length</th> </tr> </thead> <tbody> <tr> <td>no groove</td> <td>0.14-0.37 mm²</td> <td>AWG 26-22</td> <td>7,5 mm</td> </tr> <tr> <td>no groove</td> <td>0.5 mm²</td> <td>AWG 20</td> <td>7,5 mm</td> </tr> <tr> <td>1 groove*</td> <td>0.75 mm²</td> <td>AWG 18</td> <td>7,5 mm</td> </tr> <tr> <td>1 groove</td> <td>1 mm²</td> <td>AWG 18</td> <td>7,5 mm</td> </tr> <tr> <td>2 grooves</td> <td>1.5 mm²</td> <td>AWG 16</td> <td>7,5 mm</td> </tr> <tr> <td>3 grooves</td> <td>2.5 mm²</td> <td>AWG 14</td> <td>7,5 mm</td> </tr> <tr> <td>wide groove</td> <td>3.0 mm²</td> <td>AWG 12</td> <td>7,5 mm</td> </tr> <tr> <td>no groove</td> <td>4 mm²</td> <td>AWG 12</td> <td>7,5 mm</td> </tr> </tbody> </table>	Identification	Wire gauge	AWG	Stripping length	no groove	0.14-0.37 mm²	AWG 26-22	7,5 mm	no groove	0.5 mm²	AWG 20	7,5 mm	1 groove*	0.75 mm²	AWG 18	7,5 mm	1 groove	1 mm²	AWG 18	7,5 mm	2 grooves	1.5 mm²	AWG 16	7,5 mm	3 grooves	2.5 mm²	AWG 14	7,5 mm	wide groove	3.0 mm²	AWG 12	7,5 mm	no groove	4 mm²	AWG 12	7,5 mm	
	Identification	Wire gauge	AWG		Stripping length																																				
	no groove	0.14-0.37 mm²	AWG 26-22		7,5 mm																																				
	no groove	0.5 mm²	AWG 20		7,5 mm																																				
	1 groove*	0.75 mm²	AWG 18		7,5 mm																																				
1 groove	1 mm²	AWG 18	7,5 mm																																						
2 grooves	1.5 mm²	AWG 16	7,5 mm																																						
3 grooves	2.5 mm²	AWG 14	7,5 mm																																						
wide groove	3.0 mm²	AWG 12	7,5 mm																																						
no groove	4 mm²	AWG 12	7,5 mm																																						
Relay contact silver plated 	0.75-1	09 33 000 6109																																							
	1.5	09 33 000 6110																																							
	2.5	09 33 000 6111																																							

Coding Pin 		09 33 000 9954	Use of the coding pin prevents incorrect mating to other connectors of the same type. The male pin should be omitted from the opposing cavity in the male insert.
----------------	--	-----------------------	--

* only to be used with BUCHANAN crimping tool 09 99 000 0001 and adjustment gauge 09 99 000 0203

Stock items in bold type

Number of contacts

46 +



Inserts

Identification	Series	Part No.		Drawing	Dimensions in mm
		Male insert (M)	Female insert (F)		
Crimp terminal Order contacts separately	Han® EE	09 32 046 3001	09 32 046 3101	<p>1) Distance for contact max. 21 mm</p> <p> Contact arrangement View from termination side </p> <p> Panel cut out for inserts for use without hoods/housings </p>	

Identification	Wire gauge (mm²)	Part No.		Drawing	Dimensions in mm																											
		Male contacts	Female contacts																													
Crimp contacts Power contacts silver plated	0.14-0.37 0.5 0.75 1.0 1.5 2.5 3 4	09 33 000 6127* 09 33 000 6121 09 33 000 6114 09 33 000 6105 09 33 000 6104 09 33 000 6102 09 33 000 6106 09 33 000 6107	09 33 000 6227* 09 33 000 6220 09 33 000 6214 09 33 000 6205 09 33 000 6204 09 33 000 6206 09 33 000 6207	<p>Operation contact Identification</p> <p>Relay contact</p> <p>Crimp contact identification</p> <table border="1"> <thead> <tr> <th>Identification</th> <th>Wire gauge</th> <th>Stripping length</th> </tr> </thead> <tbody> <tr> <td>no groove</td> <td>0.14-0.37 mm²</td> <td>AWG 26-22</td> </tr> <tr> <td>no groove</td> <td>0.5 mm²</td> <td>AWG 20</td> </tr> <tr> <td>1 groove*</td> <td>0.75 mm²</td> <td>AWG 18</td> </tr> <tr> <td>1 groove</td> <td>1 mm²</td> <td>AWG 18</td> </tr> <tr> <td>2 grooves</td> <td>1.5 mm²</td> <td>AWG 16</td> </tr> <tr> <td>3 grooves</td> <td>2.5 mm²</td> <td>AWG 14</td> </tr> <tr> <td>wide groove</td> <td>3.0 mm²</td> <td>AWG 12</td> </tr> <tr> <td>no groove</td> <td>4 mm²</td> <td>AWG 12</td> </tr> </tbody> </table>	Identification	Wire gauge	Stripping length	no groove	0.14-0.37 mm²	AWG 26-22	no groove	0.5 mm²	AWG 20	1 groove*	0.75 mm²	AWG 18	1 groove	1 mm²	AWG 18	2 grooves	1.5 mm²	AWG 16	3 grooves	2.5 mm²	AWG 14	wide groove	3.0 mm²	AWG 12	no groove	4 mm²	AWG 12	7.5 mm 7.5 mm 7.5 mm 7.5 mm 7.5 mm 7.5 mm 7.5 mm
Identification	Wire gauge	Stripping length																														
no groove	0.14-0.37 mm²	AWG 26-22																														
no groove	0.5 mm²	AWG 20																														
1 groove*	0.75 mm²	AWG 18																														
1 groove	1 mm²	AWG 18																														
2 grooves	1.5 mm²	AWG 16																														
3 grooves	2.5 mm²	AWG 14																														
wide groove	3.0 mm²	AWG 12																														
no groove	4 mm²	AWG 12																														
gold plated	0.14-0.37 0.5 0.75 1.0 1.5 2.5 4.0	09 33 000 6117* 09 33 000 6122 09 33 000 6115 09 33 000 6118 09 33 000 6116 09 33 000 6123 09 33 000 6119	09 33 000 6217* 09 33 000 6222 09 33 000 6215 09 33 000 6218 09 33 000 6216 09 33 000 6223 09 33 000 6221	* on the back crimp collar	7.5 mm 7.5 mm 7.5 mm 7.5 mm 7.5 mm 7.5 mm 7.5 mm																											

FOC contacts for 1 mm plastic fibre		20 10 001 3311	20 10 001 3321	
---	--	----------------	----------------	--

Coding Pin		09 33 000 9954		Use of the coding pin prevents incorrect mating to other connectors of the same type. The male pin should be omitted from the opposing cavity in the male insert.
-------------------	--	-----------------------	--	--

* only to be used with BUCHANAN crimping tool 09 99 000 0001 and adjustment gauge 09 99 000 0203

Han
E/EE

Identification	Part No.			Drawing	Dimensions in mm					
	Low construction	High construction	M							
Hoods	Hoods side-entry 	19 30 024 1521 19 30 024 1522	19 30 024 0527 19 30 024 0528	25 32 32 40						
	Hoods top-entry 	19 30 024 1422	19 30 024 0427 19 30 024 0428	32 40						
	Protection covers for hoods thermoplastic/metal 	09 30 024 5401 09 30 024 5422								
Housings	Housing bulkhead mounting 	09 30 024 0301		—	Panel cut out 108 x 35 mm 					
	Housings surface mounting 	19 30 024 1231	19 30 024 0232	25 32						
	1 side-entry 19 30 024 1271	19 30 024 0272 19 30 024 0273	25 32 40	Blind way for one cable entry <table border="1"> <thead> <tr> <th></th> <th>h</th> </tr> </thead> <tbody> <tr> <td>Low construction</td> <td>56</td> </tr> <tr> <td>High construction</td> <td>81</td> </tr> </tbody> </table>		h	Low construction	56	High construction	81
		h								
	Low construction	56								
	High construction	81								
2 side-entries 09 30 024 5405										
Protection covers for housings bulkhead/surface mounting thermoplastic/metal 	09 30 024 5425									
Hoods cable to cable 	19 30 024 1732	19 30 024 0737 19 30 024 0738	32 40	<table border="1"> <thead> <tr> <th></th> <th>h</th> </tr> </thead> <tbody> <tr> <td>Low construction</td> <td>57.5</td> </tr> <tr> <td>High construction</td> <td>78.5</td> </tr> </tbody> </table>		h	Low construction	57.5	High construction	78.5
	h									
Low construction	57.5									
High construction	78.5									
Protection cover for hoods metal 	09 30 024 5426									

Identification	Part No.			Drawing	Dimensions in mm
	Low construction	High construction	M		
Hoods	Hoods side-entry 	19 30 024 1541 19 30 024 1542		25 32	
			19 30 024 0547 19 30 024 0548	32 40	
	Hoods top-entry 	19 30 024 1442	19 30 024 0447	32	
			19 30 024 0448	40	
Housings	Housings bulkhead mounting 	09 30 024 0307 with thermo-plastic cover 09 30 024 0304 with metal cover 09 30 024 0318		—	Panel cut out 108 x 35 mm
	Housings surface mounting 	1 side-entry 19 30 024 1251		25	
		2 side-entries 19 30 024 1291	19 30 024 0292	25 32	
		1 side-entry 19 30 024 1256 with thermo-plastic cover 19 30 024 1296 with thermo-plastic cover 19 30 024 1296 with metal cover 19 30 024 2296	with thermo-plastic cover 19 30 024 0297 with metal cover 19 30 024 7297	25 25 32 25 32	
	Hoods cable to cable 	19 30 024 1752	19 30 024 0757	32	
	Dust protection cover 	09 30 024 5406			

Han
E/EE

	h
Low construction	56
High construction	81

	h
Low construction	57.5
High construction	78.5

Number of contacts

32 +

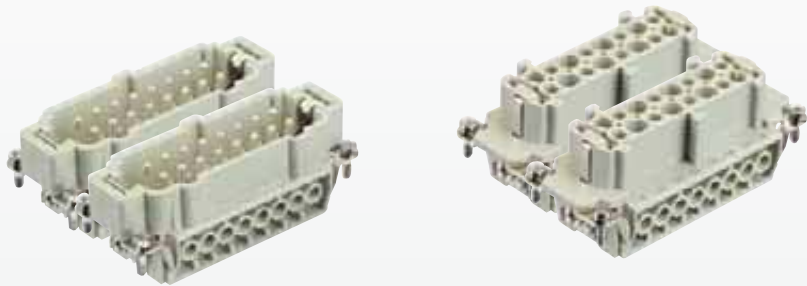

Inserts

Han E/EE

Identification	Series	Part No.		Drawing	Dimensions in mm
		Male insert (M)	Female insert (F)		
Screw terminal with wire protection 	Han E®			Dimensions for inserts see page 03.22 Contact arrangement View from termination side 	
	1-16 17-32	09 33 016 2601 09 33 016 2611	09 33 016 2701 09 33 016 2711		
Cage-clamp terminal 	Han® ES				
	1-16 17-32	09 33 016 2616 09 33 016 2626	09 33 016 2716 09 33 016 2726		
Cage-clamp terminal two terminals per contact 	Han® ESS				Panel cut out for inserts for use without hoods/housings
	1-16 1-16	09 33 016 2672 09 33 016 2672	09 33 016 2772 09 33 016 2772		
Crimp terminal Order contacts separately 	Han E®				
	1-16 17-32	09 33 016 2602 09 33 016 2612	09 33 016 2702 09 33 016 2712		

Identification	Wire gauge (mm²)	Part No.		Drawing	Dimensions in mm																											
		Male contacts	Female contacts																													
Crimp contacts Power contacts silver plated 	0.14-0.37 0.5 0.75 1.0 1.5 2.5 3 4	09 33 000 6127* 09 33 000 6121 09 33 000 6114 09 33 000 6105 09 33 000 6104 09 33 000 6102 09 33 000 6106 09 33 000 6107	09 33 000 6227* 09 33 000 6220 09 33 000 6214 09 33 000 6205 09 33 000 6204 09 33 000 6202 09 33 000 6206 09 33 000 6207	Operating contact Identification Relay contact 																												
gold plated 	0.14-0.37 0.5 0.75 1.0 1.5 2.5 4.0	09 33 000 6117* 09 33 000 6122 09 33 000 6115 09 33 000 6118 09 33 000 6116 09 33 000 6123 09 33 000 6119	09 33 000 6217* 09 33 000 6222 09 33 000 6215 09 33 000 6218 09 33 000 6216 09 33 000 6223 09 33 000 6221																													
Relay contact silver plated 	0.75-1 1.5 2.5	09 33 000 6109 09 33 000 6110 09 33 000 6111		Crimp contact identification <table border="1"> <thead> <tr> <th>Identification</th> <th>Wire gauge</th> <th>Stripping length</th> </tr> </thead> <tbody> <tr> <td>no groove</td> <td>0.14-0.37 mm²</td> <td>AWG 26-22</td> </tr> <tr> <td>no groove</td> <td>0.5 mm²</td> <td>AWG 20</td> </tr> <tr> <td>1 groove*</td> <td>0.75 mm²</td> <td>AWG 18</td> </tr> <tr> <td>1 groove</td> <td>1 mm²</td> <td>AWG 18</td> </tr> <tr> <td>2 grooves</td> <td>1.5 mm²</td> <td>AWG 16</td> </tr> <tr> <td>3 grooves</td> <td>2.5 mm²</td> <td>AWG 14</td> </tr> <tr> <td>wide groove</td> <td>3.0 mm²</td> <td>AWG 12</td> </tr> <tr> <td>no groove</td> <td>4 mm²</td> <td>AWG 12</td> </tr> </tbody> </table>	Identification	Wire gauge	Stripping length	no groove	0.14-0.37 mm²	AWG 26-22	no groove	0.5 mm²	AWG 20	1 groove*	0.75 mm²	AWG 18	1 groove	1 mm²	AWG 18	2 grooves	1.5 mm²	AWG 16	3 grooves	2.5 mm²	AWG 14	wide groove	3.0 mm²	AWG 12	no groove	4 mm²	AWG 12	
Identification	Wire gauge	Stripping length																														
no groove	0.14-0.37 mm²	AWG 26-22																														
no groove	0.5 mm²	AWG 20																														
1 groove*	0.75 mm²	AWG 18																														
1 groove	1 mm²	AWG 18																														
2 grooves	1.5 mm²	AWG 16																														
3 grooves	2.5 mm²	AWG 14																														
wide groove	3.0 mm²	AWG 12																														
no groove	4 mm²	AWG 12																														

Coding Pin 		09 33 000 9954	Use of the coding pin prevents incorrect mating to other connectors of the same type. The male pin should be omitted from the opposing cavity in the male insert.
-----------------------	--	-----------------------	--

* only to be used with BUCHANAN crimping tool 09 99 000 0001 and adjustment gauge 09 99 000 0203

Number of contacts

64 +

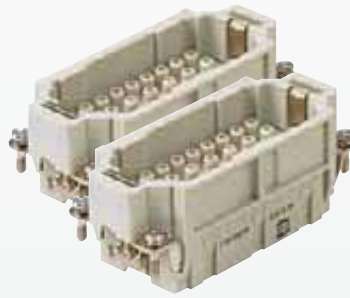







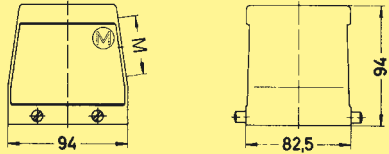

Inserts

Identification	Series	Part No.		Drawing	Dimensions in mm
		Male insert (M)	Female insert (F)		
Crimp terminal Order contacts separately	Han® EE			Dimensions for inserts see page 03.23	
	1-32 33-64	09 32 032 3001 09 32 032 3011	09 32 032 3101 09 32 032 3111	<p>Contact arrangement View from termination side</p> <p>Panel cut out for inserts for use without hoods/housings</p>	

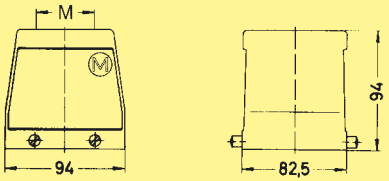
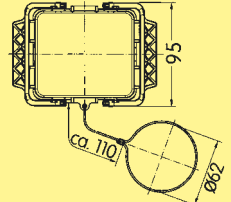
Identification	Wire gauge (mm²)	Part No.		Drawing	Dimensions in mm																											
		Male contacts	Female contacts																													
Crimp contacts				<p>Operation contact Identification</p> <p>Crimp contact identification</p> <table border="1"> <thead> <tr> <th>Identification</th> <th>Wire gauge</th> <th>Stripping length</th> </tr> </thead> <tbody> <tr> <td>no groove</td> <td>0.14-0.37 mm²</td> <td>AWG 26-22</td> </tr> <tr> <td>no groove</td> <td>0.5 mm²</td> <td>AWG 20</td> </tr> <tr> <td>1 groove*</td> <td>0.75 mm²</td> <td>AWG 18</td> </tr> <tr> <td>1 groove</td> <td>1 mm²</td> <td>AWG 18</td> </tr> <tr> <td>2 grooves</td> <td>1.5 mm²</td> <td>AWG 16</td> </tr> <tr> <td>3 grooves</td> <td>2.5 mm²</td> <td>AWG 14</td> </tr> <tr> <td>wide groove</td> <td>3.0 mm²</td> <td>AWG 12</td> </tr> <tr> <td>no groove</td> <td>4 mm²</td> <td>AWG 12</td> </tr> </tbody> </table> <p>* on the back crimp collar</p>	Identification	Wire gauge	Stripping length	no groove	0.14-0.37 mm²	AWG 26-22	no groove	0.5 mm²	AWG 20	1 groove*	0.75 mm²	AWG 18	1 groove	1 mm²	AWG 18	2 grooves	1.5 mm²	AWG 16	3 grooves	2.5 mm²	AWG 14	wide groove	3.0 mm²	AWG 12	no groove	4 mm²	AWG 12	
Identification	Wire gauge	Stripping length																														
no groove	0.14-0.37 mm²	AWG 26-22																														
no groove	0.5 mm²	AWG 20																														
1 groove*	0.75 mm²	AWG 18																														
1 groove	1 mm²	AWG 18																														
2 grooves	1.5 mm²	AWG 16																														
3 grooves	2.5 mm²	AWG 14																														
wide groove	3.0 mm²	AWG 12																														
no groove	4 mm²	AWG 12																														
Power contacts	0.14-0.37 0.5 0.75 1.0 1.5 2.5 3 4	09 33 000 6127* 09 33 000 6121 09 33 000 6114 09 33 000 6105 09 33 000 6104 09 33 000 6102 09 33 000 6106 09 33 000 6107	09 33 000 6227* 09 33 000 6220 09 33 000 6214 09 33 000 6205 09 33 000 6204 09 33 000 6202 09 33 000 6206 09 33 000 6207																													
silver plated																																
gold plated	0.14-0.37 0.5 0.75 1.0 1.5 2.5 4.0	09 33 000 6117* 09 33 000 6122 09 33 000 6115 09 33 000 6118 09 33 000 6116 09 33 000 6123 09 33 000 6119	09 33 000 6217* 09 33 000 6222 09 33 000 6215 09 33 000 6218 09 33 000 6216 09 33 000 6223 09 33 000 6221																													
FOC contacts for 1 mm plastic fibre		20 10 001 3311	20 10 001 3321																													
Coding Pin		09 33 000 9954		<p>Use of the coding pin prevents incorrect mating to other connectors of the same type.</p> <p>The male pin should be omitted from the opposing cavity in the male insert.</p>																												

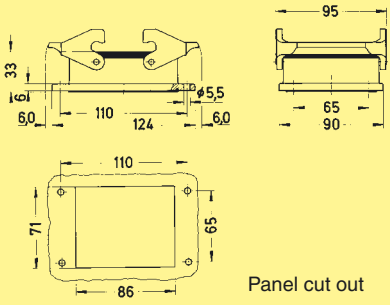
* only to be used with BUCHANAN crimping tool 09 99 000 0001 and adjustment gauge 09 99 000 0203

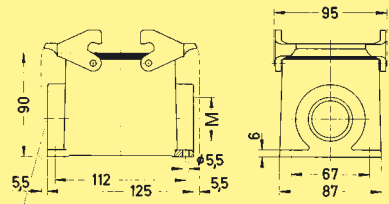
Han
E/EE

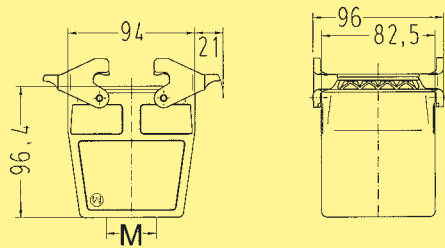
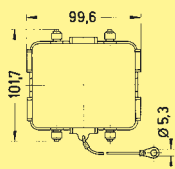

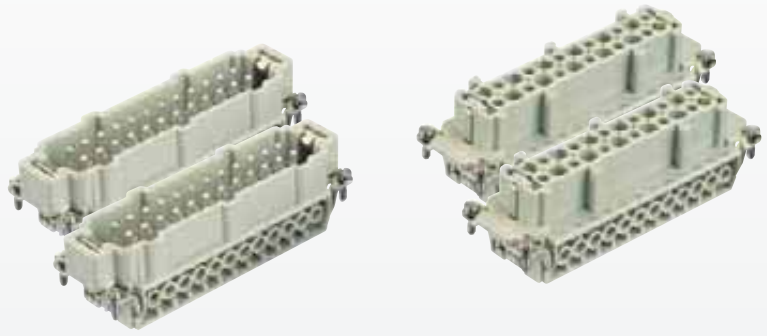

Identification	Part No.	M	Drawing	Dimensions in mm
Hoods side-entry 	19 30 032 0527 19 30 032 0528 19 30 032 0529	32 40 50		94 82,5 94
Hoods top-entry 	19 30 032 0427 19 30 032 0428 19 30 032 0429	32 40 50		94 82,5 94
Protection cover for hoods	09 30 032 5420	-		95 ca. 110 Ø82
Housing bulkhead mounting 	09 30 032 0301	-		95 65 90 Panel cut out
Housings surface mounting 	19 30 032 0232 19 30 032 0272 19 30 032 0273	1 x 32 2 x 32 2 x 40		95 67 87 Blind way for one cable entry
Hoods cable to cable 	19 30 032 0738	1 x 40		96 82,5 M
Protection covers for housings	09 30 032 5425	-		1017 99,6 Ø5,3

Number of contacts

48 + 

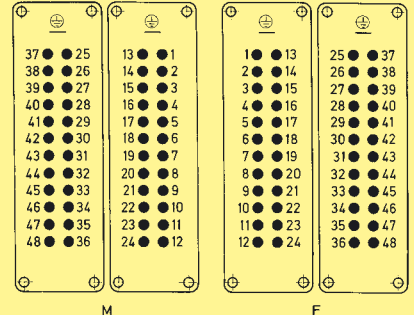



Inserts

Identification	Series	Part No.		Drawing	Dimensions in mm
		Male insert (M)	Female insert (F)		
Screw terminal with wire protection 	Han E®			Dimensions for inserts see page 03.26 Contact arrangement View from termination side 	Han E/EE
	1-24	09 33 024 2601	09 33 024 2701		
	25-48	09 33 024 2611	09 33 024 2711		
Cage-clamp terminal 	Han® ES				
	1-24	09 33 024 2616	09 33 024 2716		
	25-48	09 33 024 2626	09 33 024 2726		
Cage-clamp terminal two terminals per contact 	Han® ESS				
	1-24	09 33 024 2672	09 33 024 2772		
	1-24	09 33 024 2672	09 33 024 2772		
Crimpanschluss Order contacts separately 	Han E®				
	1-24	09 33 024 2602	09 33 024 2702		
	25-48	09 33 024 2612	09 33 024 2712		

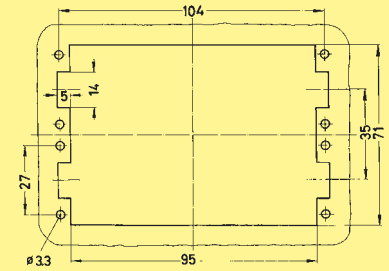
Panel cut out for inserts for use without hoods/housings

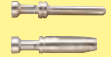
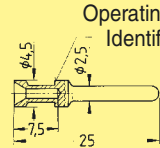
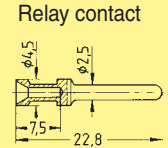

Identification	Wire gauge (mm²)	Part No.		Drawing	Dimensions in mm																																						
		Male contacts	Female contacts																																								
Crimp contacts Power contacts silver plated 	0.14-0.37	09 33 000 6127*	09 33 000 6227*	Operating contact Identification 	Relay contact 																																						
	0.5	09 33 000 6121	09 33 000 6220																																								
	0.75	09 33 000 6114	09 33 000 6214																																								
	1.0	09 33 000 6105	09 33 000 6205																																								
	1.5	09 33 000 6104	09 33 000 6204																																								
	2.5	09 33 000 6102	09 33 000 6202																																								
	3	09 33 000 6106	09 33 000 6206																																								
	4	09 33 000 6107	09 33 000 6207																																								
gold plated 	0.14-0.37	09 33 000 6117*	09 33 000 6217*	Crimp contact identification <table border="1"> <thead> <tr> <th>Identification</th> <th>Wire gauge</th> <th>AWG</th> <th>Stripping length</th> </tr> </thead> <tbody> <tr> <td>no groove</td> <td>0.14-0.37 mm²</td> <td>AWG 26-22</td> <td>7,5 mm</td> </tr> <tr> <td>no groove</td> <td>0.5 mm²</td> <td>AWG 20</td> <td>7,5 mm</td> </tr> <tr> <td>1 groove*</td> <td>0.75 mm²</td> <td>AWG 18</td> <td>7,5 mm</td> </tr> <tr> <td>1 groove</td> <td>1 mm²</td> <td>AWG 18</td> <td>7,5 mm</td> </tr> <tr> <td>2 grooves</td> <td>1.5 mm²</td> <td>AWG 16</td> <td>7,5 mm</td> </tr> <tr> <td>3 grooves</td> <td>2.5 mm²</td> <td>AWG 14</td> <td>7,5 mm</td> </tr> <tr> <td>wide groove</td> <td>3.0 mm²</td> <td>AWG 12</td> <td>7,5 mm</td> </tr> <tr> <td>no groove</td> <td>4 mm²</td> <td>AWG 12</td> <td>7,5 mm</td> </tr> </tbody> </table>	Identification	Wire gauge	AWG	Stripping length	no groove	0.14-0.37 mm²	AWG 26-22	7,5 mm	no groove	0.5 mm²	AWG 20	7,5 mm	1 groove*	0.75 mm²	AWG 18	7,5 mm	1 groove	1 mm²	AWG 18	7,5 mm	2 grooves	1.5 mm²	AWG 16	7,5 mm	3 grooves	2.5 mm²	AWG 14	7,5 mm	wide groove	3.0 mm²	AWG 12	7,5 mm	no groove	4 mm²	AWG 12	7,5 mm	0.5	09 33 000 6122	09 33 000 6222
Identification	Wire gauge	AWG	Stripping length																																								
no groove	0.14-0.37 mm²	AWG 26-22	7,5 mm																																								
no groove	0.5 mm²	AWG 20	7,5 mm																																								
1 groove*	0.75 mm²	AWG 18	7,5 mm																																								
1 groove	1 mm²	AWG 18	7,5 mm																																								
2 grooves	1.5 mm²	AWG 16	7,5 mm																																								
3 grooves	2.5 mm²	AWG 14	7,5 mm																																								
wide groove	3.0 mm²	AWG 12	7,5 mm																																								
no groove	4 mm²	AWG 12	7,5 mm																																								
	0.75	09 33 000 6115	09 33 000 6215																																								
	1.0	09 33 000 6118	09 33 000 6218																																								
	1.5	09 33 000 6116	09 33 000 6216																																								
	2.5	09 33 000 6123	09 33 000 6223																																								
	4.0	09 33 000 6119	09 33 000 6221																																								
Relay contact silver plated 	0.75-1	09 33 000 6109																																									
	1.5	09 33 000 6110																																									
	2.5	09 33 000 6111																																									

* on the back crimp collar

Coding Pin



09 33 000 9954

Use of the coding pin prevents incorrect mating to other connectors of the same type.

The male pin should be omitted from the opposing cavity in the male insert.

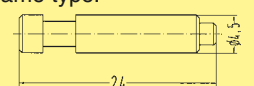

* only to be used with BUCHANAN crimping tool 09 99 000 0001 and adjustment gauge 09 99 000 0203

Number of contacts

92 +

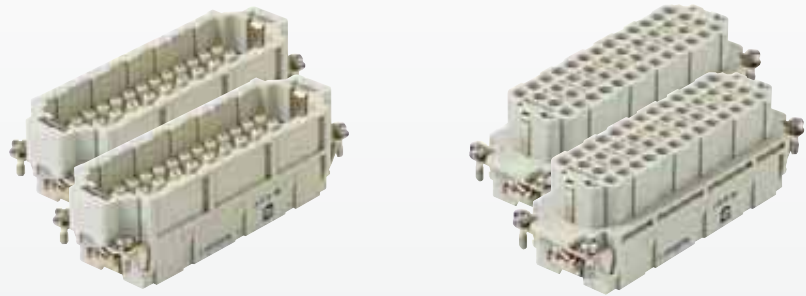

Inserts

Han E/EE







Identification	Series	Part No.		Drawing	Dimensions in mm
		Male insert (M)	Female insert (F)		
Crimp terminal Order contacts separately	Han® EE			Dimensions for inserts see page 03.27 Contact arrangement View from termination side	
	1-46 47-92	09 32 046 3001 09 32 046 3011	09 32 046 3101 09 32 046 3111	<p>M F</p>	
				<p>Panel cut out for inserts for use without hoods/housings</p>	

Identification	Wire gauge (mm²)	Part No.		Drawing	Dimensions in mm																											
		Male contacts	Female contacts																													
Crimp contacts				Operation contact Identification	Relay contact																											
Power contacts	0.14-0.37 0.5 0.75 1.0 1.5 2.5 3 4	09 33 000 6127* 09 33 000 6121 09 33 000 6114 09 33 000 6105 09 33 000 6104 09 33 000 6102 09 33 000 6106 09 33 000 6107	09 33 000 6227* 09 33 000 6220 09 33 000 6214 09 33 000 6205 09 33 000 6204 09 33 000 6202 09 33 000 6206 09 33 000 6207																													
silver plated				Crimp contact identification																												
gold plated	0.14-0.37 0.5 0.75 1.0 1.5 2.5 4.0	09 33 000 6117* 09 33 000 6122 09 33 000 6115 09 33 000 6118 09 33 000 6116 09 33 000 6123 09 33 000 6119	09 33 000 6217* 09 33 000 6222 09 33 000 6215 09 33 000 6218 09 33 000 6216 09 33 000 6223 09 33 000 6221	<table border="1"> <thead> <tr> <th>Identification</th> <th>Wire gauge</th> <th>Stripping length</th> </tr> </thead> <tbody> <tr> <td>no groove</td> <td>0.14-0.37 mm²</td> <td>AWG 26-22</td> </tr> <tr> <td>no groove</td> <td>0.5 mm²</td> <td>AWG 20</td> </tr> <tr> <td>1 groove*</td> <td>0.75 mm²</td> <td>AWG 18</td> </tr> <tr> <td>1 groove</td> <td>1 mm²</td> <td>AWG 18</td> </tr> <tr> <td>2 grooves</td> <td>1.5 mm²</td> <td>AWG 16</td> </tr> <tr> <td>3 grooves</td> <td>2.5 mm²</td> <td>AWG 14</td> </tr> <tr> <td>wide groove</td> <td>3.0 mm²</td> <td>AWG 12</td> </tr> <tr> <td>no groove</td> <td>4 mm²</td> <td>AWG 12</td> </tr> </tbody> </table>		Identification	Wire gauge	Stripping length	no groove	0.14-0.37 mm²	AWG 26-22	no groove	0.5 mm²	AWG 20	1 groove*	0.75 mm²	AWG 18	1 groove	1 mm²	AWG 18	2 grooves	1.5 mm²	AWG 16	3 grooves	2.5 mm²	AWG 14	wide groove	3.0 mm²	AWG 12	no groove	4 mm²	AWG 12
Identification	Wire gauge	Stripping length																														
no groove	0.14-0.37 mm²	AWG 26-22																														
no groove	0.5 mm²	AWG 20																														
1 groove*	0.75 mm²	AWG 18																														
1 groove	1 mm²	AWG 18																														
2 grooves	1.5 mm²	AWG 16																														
3 grooves	2.5 mm²	AWG 14																														
wide groove	3.0 mm²	AWG 12																														
no groove	4 mm²	AWG 12																														

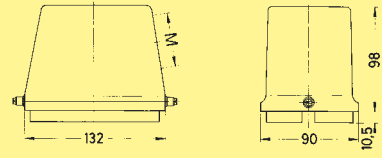
FOC contacts for 1 mm plastic fibre		20 10 001 3311	20 10 001 3321	
-------------------------------------	--	----------------	----------------	--

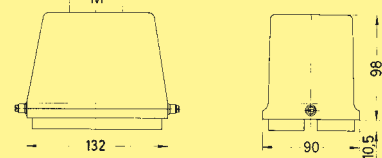
Coding Pin		09 33 000 9954		
				<p>Use of the coding pin prevents incorrect mating to other connectors of the same type.</p> <p>The male pin should be omitted from the opposing cavity in the male insert.</p>

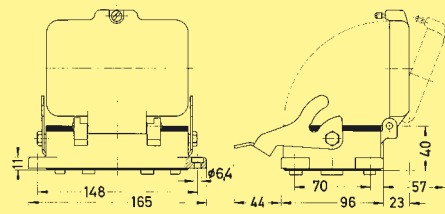
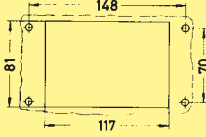
* only to be used with BUCHANAN crimping tool 09 99 000 0001 and adjustment gauge 09 99 000 0203

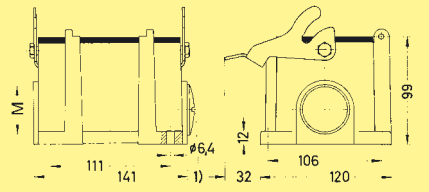
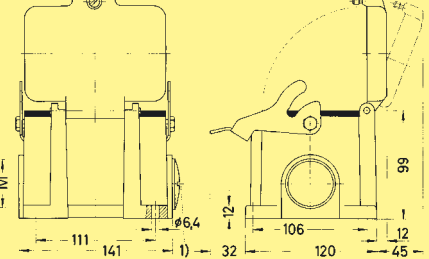
Identification	Part No.	M	Drawing	Dimensions in mm	
Hoods	Hoods side-entry 	19 30 048 0548 19 30 048 0549	40 50		
	Hoods top-entry 	19 30 048 0448 19 30 048 0449	40 50		
Housings	Housings bulkhead mounting 	with thermo-plastic cover 09 30 048 0301	—		
		with metal cover 09 30 048 0317	—	Panel cut out 	
Housings	Housings surface mounting 2 side-entries 	19 30 048 0292 19 30 048 0293	2 x 32 2 x 40		
		with thermo-plastic cover 19 30 048 0298	2 x 40		

Han
E/EE

Modified contact arrangement up to 1000 V

The connector series Han® EE equipped with all contacts may be used for voltages up to 500 V ~ pollution degree 3. A modified contact loading arrangement permits use up to 1000 V ~ pollution degree also in pollution degree C.

Fully equipped connectors may also be used up to 1000 V ~ but in a lower pollution degree. See page 00.17.

According to DIN EN 61 984 connectors should not be coupled or decoupled under electrical load.

Han
E/EE

690 V Pollution degree 3

Contact arrangement View from termination side

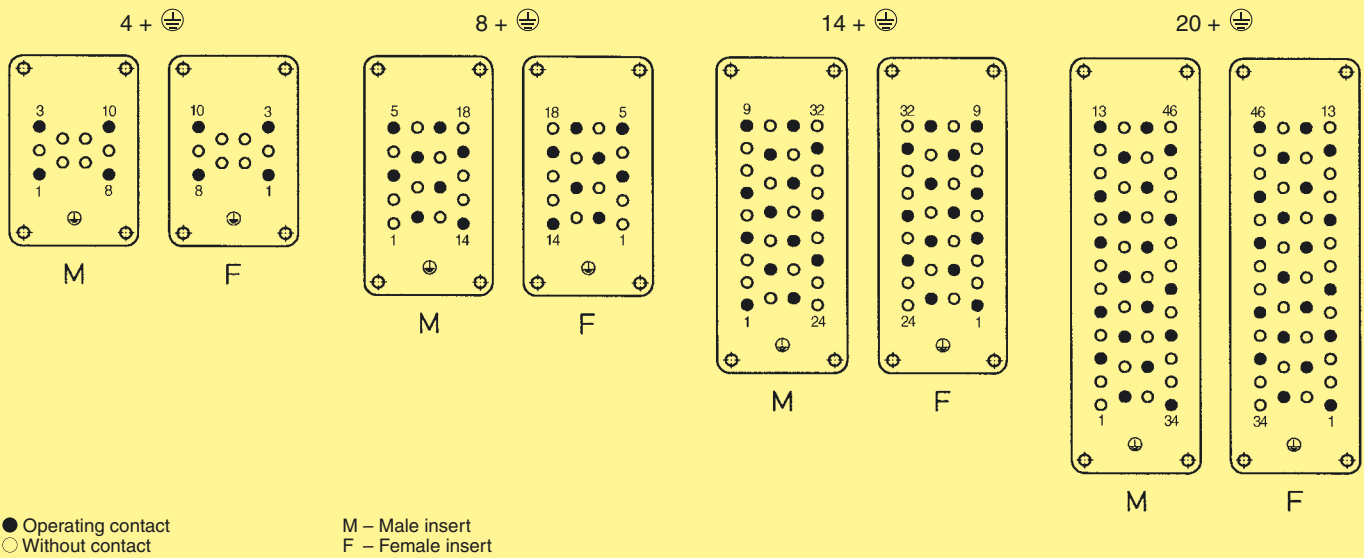

1 000 V Pollution degree 3

Contact arrangement View from termination side

