

4

3

2

1

THIS DRAWING IS UNPUBLISHED.

RELEASED FOR PUBLICATION

© COPYRIGHT - BY TYCO ELECTRONICS CORPORATION. ALL RIGHTS RESERVED.

LOC	DIST	REVISIONS					
H	-	P	LTR	DESCRIPTION	DATE	DWN	APVD
			12	CHANGED HOUSING COLOR	06JUL2016	KR	MVE
			13	UL, KEMA LOGO PENDING	20JUL2016	MVE	
			14	CHANGED LASER MARKING	09AUG2016	KR	MvE
			15	CHANGED IP CLASS	06SEP2016	KR	MvE

DIMENSIONS BEFORE APPLICATION

NOTES:

- 2213600-1 AS SHOWN.
- MATERIALS:

CONTACT: PHOSPHOR BRONZE, TIN PLATED
 HOUSING: PC NOT GLASS FILLED
 BUTTONS: PC NOT GLASS FILLED

3 LASER MARKING:
 • (KEMA) PENDING
 • (UL) PENDING
 • TE LOGO
 • TE PART NUMBER
 • DATE CODE

4 LASER MARKING: IP20

5 LASER MARKING: IP x5/x7

**PRELIMINARY PART
 NOT RELEASED FOR PRODUCTION**

**THIS PRODUCT HAS NOT COMPLETED
 VALIDATION TESTING**

UNSEALED	4	A=4.0 B=3.5	14/16 TO 16/18	BLUE AND RED	CLEAR	2213600-6
UNSEALED	4	A=4.5 B=3.5	12/14 TO 16/18	YELLOW AND RED	CLEAR	2213600-5
UNSEALED	4	A=4.5 B=4.0	12/14 TO 14/16	YELLOW AND BLUE	CLEAR	2213600-4
SEALED	5	A=4.0 B=3.5	14/16 TO 16/18	BLUE AND RED	CLEAR	2213600-3
SEALED	5	A=4.5 B=3.5	12/14 TO 16/18	YELLOW AND RED	CLEAR	2213600-2
SEALED	5	A=4.5 B=4.0	12/14 TO 14/16	YELLOW AND BLUE	CLEAR	2213600-1
SEALING		WIRE ENTRY	WIRE SIZE	BUTTON COLORS	HOUSING COLOR	PART NUMBER

THIS DRAWING IS A CONTROLLED DOCUMENT.
 DIMENSIONING AND TOLERANCING PER ASME Y14.5M-2009.

DIMENSIONS:	TOLERANCES UNLESS OTHERWISE SPECIFIED:
mm	
	0 PLC ±-
	1 PLC ±0,2
	2 PLC ±0,2
	3 PLC ±-
	4 PLC ±-
	ANGLES ±-
MATERIAL	FINISH
-	-

DWN 06 NOV '15
 M.V.ESSEN
 CHK -
 C.V.STEENDEREN
 APVD -
 O.I.FIJNSE
 PRODUCT SPEC
 108-133061
 APPLICATION SPEC
 114-133061
 WEIGHT -
 CUSTOMER DRAWING

PRELIMINARY TE Connectivity
 COOL SPLICE
 ONE POSITION LARGE WIRE GAUGE

SIZE	CAGE CODE	DRAWING NO	RESTRICTED TO
A3	00779	©-2213600	-

SCALE 2:1 SHEET 1 OF 3 REV 15

1470-19 (3/11)

THIS DRAWING IS UNPUBLISHED.

RELEASED FOR PUBLICATION

© COPYRIGHT - BY TYCO ELECTRONICS CORPORATION. ALL RIGHTS RESERVED.

LOC	DIST	REVISIONS					
		P	LTR	DESCRIPTION	DATE	DWN	APVD
		-		SEE SHEET 1	-	-	-

DIMENSIONS AFTER APPLICATION

NOTE:
1. 2213600-1 AS SHOWN.

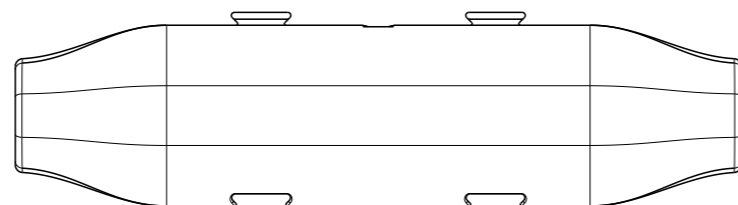
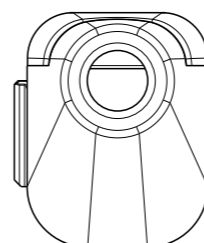
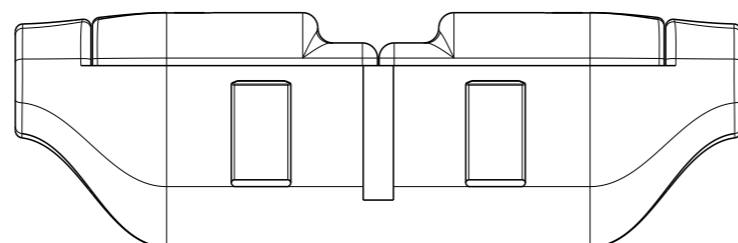
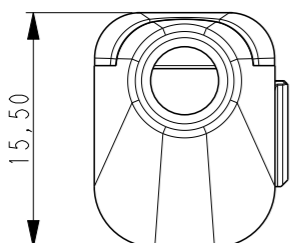
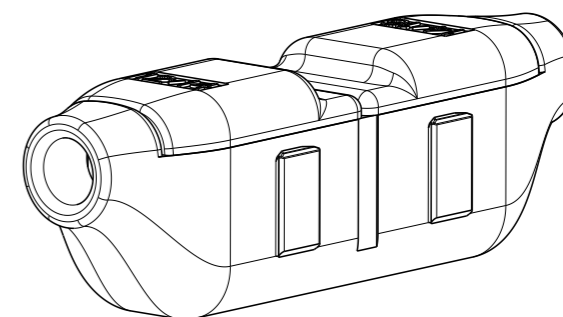
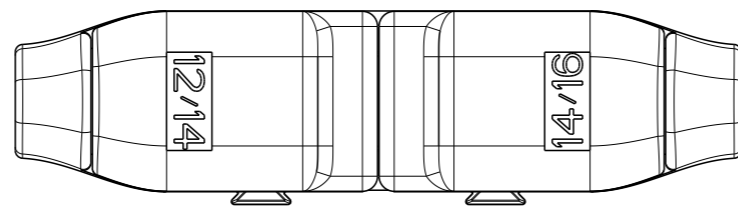

**PRELIMINARY PART
NOT RELEASED FOR PRODUCTION**

**THIS PRODUCT HAS NOT COMPLETED
VALIDATION TESTING**

THIS DRAWING IS A CONTROLLED DOCUMENT.		DWN M.V.ESSSEN	06 NOV '15		
DIMENSIONS: mm		CHK C.V.STEENDEREN	-		
TOLERANCES UNLESS OTHERWISE SPECIFIED:		APVD O.IEIJNSE	-	NAME COOL SPLICE ONE POSITION LARGE WIRE GAUGE	
0 PLC ±-		PRODUCT SPEC 108-133061	-	SIZE A3	
1 PLC ±0,2		APPLICATION SPEC 114-133061	-	CAGE CODE 00779	DRAWING NO C-2213600
2 PLC ±0,2		WEIGHT -	-	RESTRICTED TO -	
3 PLC ±-		CUSTOMER DRAWING	-	SCALE 1:1	SHEET 2 OF 3
4 PLC ±-				REV 15	
ANGLES ±-					
FINISH -					
MATERIAL -					

THIS DRAWING IS UNPUBLISHED.

RELEASED FOR PUBLICATION

© COPYRIGHT - BY TYCO ELECTRONICS CORPORATION. ALL RIGHTS RESERVED.

LOC	DIST	REVISIONS			
P	LTR	DESCRIPTION	DATE	DWN	APVD
	-	SEE SHEET 1	-	-	-

DIMENSIONS AFTER STACKING

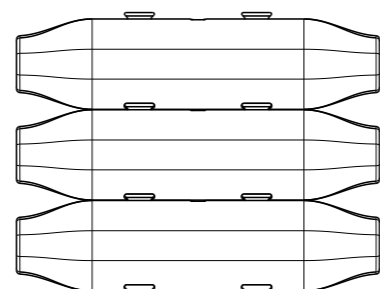
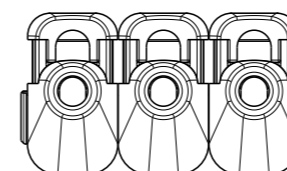
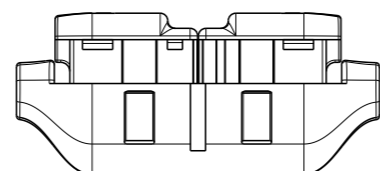
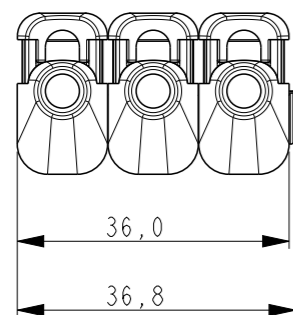
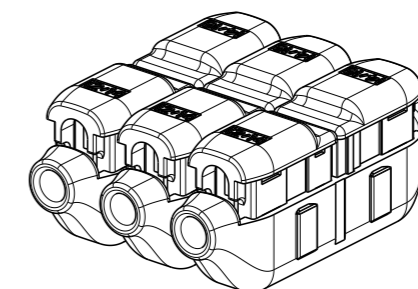
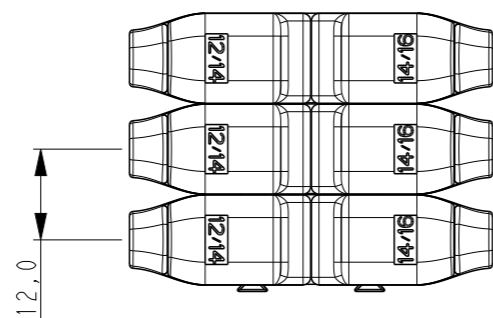

**PRELIMINARY PART
NOT RELEASED FOR PRODUCTION**

**THIS PRODUCT HAS NOT COMPLETED
VALIDATION TESTING**

THIS DRAWING IS A CONTROLLED DOCUMENT.		DWN M.V.ESSSEN 06 NOV'15														
DIMENSIONS: mm		CHK C.V.STEENDEREN														
TOLERANCES UNLESS OTHERWISE SPECIFIED:		APVD O.IEIJNSE	NAME COOL SPLICE ONE POSITION LARGE WIRE GAUGE													
<table border="0"> <tr><td>0 PLC</td><td>±-</td></tr> <tr><td>1 PLC</td><td>±0,2</td></tr> <tr><td>2 PLC</td><td>±0,2</td></tr> <tr><td>3 PLC</td><td>±-</td></tr> <tr><td>4 PLC</td><td>±-</td></tr> <tr><td>ANGLES</td><td>±-</td></tr> </table>		0 PLC	±-	1 PLC	±0,2	2 PLC	±0,2	3 PLC	±-	4 PLC	±-	ANGLES	±-	PRODUCT SPEC 108-133061	SIZE A3	
0 PLC	±-															
1 PLC	±0,2															
2 PLC	±0,2															
3 PLC	±-															
4 PLC	±-															
ANGLES	±-															
MATERIAL -		APPLICATION SPEC 114-133061	CAGE CODE 00779	DRAWING NO C-2213600												
FINISH -		WEIGHT -	RESTRICTED TO -													
CUSTOMER DRAWING			SCALE 1:1	SHEET 3 OF 3												
			REV 15													