

AS85049/17 Straight EMI/RFI Environmental Backshell



AS85049

B

CONNECTOR DESIGNATOR:

F MIL-DTL-38999 Series I and II

Finish
N = Electroless Nickel **X** = Aluminum, Nickel Fluorocarbon Polymer
W = 1,000 Hr. Cadmium Olive Drab over Electroless Nickel **Z** = Aluminum, Zinc-Nickel, Black over Electroless Nickel

M85049/17

10

N

03

A

Basic Part Number

Dash Number (Table I)

Clamp Size (Table III)

**Length Code (Table IV)
Omit for Standard**

Dash No.	Shell Size Series I	Shell Size Series II	A Thread Class 2B	B Dia Max
08	09	08	.438 - 28 UNEF	.570 (14.5)
10	11	10	.562 - 24 UNEF	.700 (17.8)
12	13	12	.688 - 24 UNEF	.830 (21.1)
14	15	14	.813 - 20 UNEF	.950 (24.1)
16	17	16	.938 - 20 UNEF	1.080 (27.4)
18	19	18	1.063 - 18 UNEF	1.200 (30.5)
20	21	20	1.188 - 18 UNEF	1.330 (33.8)
22	23	22	1.313 - 18 UNEF	1.450 (36.8)
24	25	24	1.438 - 18 UNEF	1.580 (40.1)

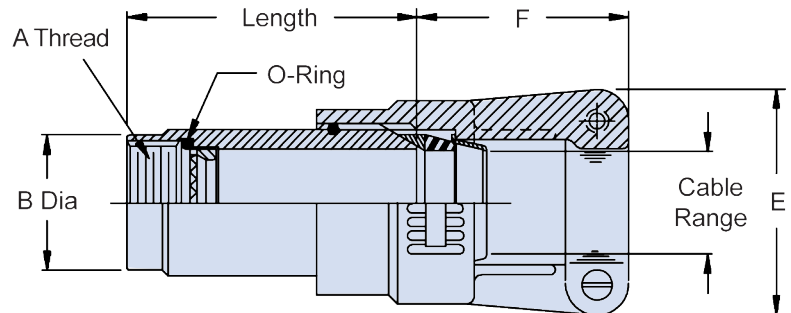

Dash No.	Shell Size Series I	Shell Size Series II	Clamp Size	
			Min	Max
08	09	08	01	02
10	11	10	01	03
12	13	12	02	04
14	15	14	02	05
16	17	16	02	06
18	19	18	03	07
20	21	20	03	08
22	23	22	03	09
24	25	24	04	10

Clamp Size	Cable Range		E Max	F Max
	Min	Max		
01	.062 (1.6)	.125 (3.2)	.781 (19.8)	1.250 (31.8)
02	.125 (3.2)	.250 (6.4)	.969 (24.6)	1.250 (31.8)
03	.250 (6.4)	.375 (9.5)	1.062 (27.0)	1.250 (31.8)
04	.375 (9.5)	.500 (12.7)	1.156 (29.4)	1.250 (31.8)
05	.500 (12.7)	.625 (15.9)	1.250 (31.8)	1.312 (33.3)
06	.625 (15.9)	.750 (19.1)	1.375 (34.9)	1.375 (34.9)
07	.750 (19.1)	.875 (22.2)	1.500 (38.1)	1.500 (38.1)
08	.875 (22.2)	1.000 (25.4)	1.625 (41.3)	1.625 (41.3)
09	1.000 (25.4)	1.125 (28.6)	1.750 (44.5)	1.625 (41.3)
10	1.125 (28.6)	1.250 (31.8)	1.875 (47.6)	1.625 (41.3)

Length Code	Available Shell Sizes	Length
Standard	08 - 24	1.500 (38.1)
A	08 - 24	2.500 (63.5)
B	14 - 24	3.500 (88.9)
C	20 - 24	4.500 (114.3)

APPLICATION NOTES

- For complete dimensions see the applicable Military Specification.
- Metric dimensions (mm) are in parentheses.
- Cable Range is defined as the accommodation range for the wire bundle or cable. Dimensions shown are not intended for inspection criteria.

Dimensions in inches (millimeters) and are subject to change without notice.