



PCA9600

Dual bidirectional bus buffer

Rev. 6 — 25 September 2015

Product data sheet

1. General description

The PCA9600 is designed to isolate I²C-bus capacitance, allowing long buses to be driven in point-to-point or multipoint applications of up to 4000 pF. The PCA9600 is a higher-speed version of the P82B96. It creates a non-latching, bidirectional, logic interface between a normal I²C-bus and a range of other higher capacitance or different voltage bus configurations. It can operate at speeds up to at least 1 MHz, and the high drive side is compatible with the Fast-mode Plus (Fm+) specifications.

The PCA9600 features temperature-stabilized logic voltage levels at its SX/SY interface making it suitable for interfacing with buses that have non I²C-bus-compliant logic levels such as SMBus, PMBus, or with microprocessors that use those same TTL logic levels.

The separation of the bidirectional I²C-bus signals into unidirectional TX and RX signals enables the SDA and SCL signals to be transmitted via balanced transmission lines (twisted pairs), or with galvanic isolation using opto or magnetic coupling. The TX and RX signals may be connected together to provide a normal bidirectional signal.

2. Features and benefits

- Bidirectional data transfer of I²C-bus signals
- Isolates capacitance allowing 400 pF on SX/SY side and 4000 pF on TX/TY side
- TX/TY outputs have 60 mA sink capability for driving low-impedance or high-capacitive buses
- 1 MHz operation on up to 20 meters of wire (see *AN10658*)
- Supply voltage range of 2.5 V to 15 V with I²C-bus logic levels on SX/SY side independent of supply voltage
- Splits I²C-bus signal into pairs of forward/reverse TX/RX, TY/RY signals for interface with opto-electrical isolators and similar devices that need unidirectional input and output signal paths
- Low power supply current
- ESD protection exceeds 3500 V HBM per JESD22-A114 and 1400 V CDM per JESD22-C101
- Latch-up testing is done to JEDEC Standard JESD78 which exceeds 100 mA
- Packages offered: SO8 and TSSOP8 (MSOP8)



3. Applications

- Interface between I²C-buses operating at different logic levels (for example, 5 V and 3 V or 15 V)
- Interface between I²C-bus and SMBus (350 μ A) standard or Fm+ standard
- Simple conversion of I²C-bus SDA or SCL signals to multi-drop differential bus hardware, for example, via compatible PCA82C250
- Interfaces with opto-couplers to provide opto-isolation between I²C-bus nodes up to 1 MHz
- Long distance point-to-point or multipoint architectures

4. Ordering information

Table 1. Ordering information

Type number	Topside marking	Package		
		Name	Description	Version
PCA9600D	PCA9600	SO8	plastic small outline package; 8 leads; body width 3.9 mm	SOT96-1
PCA9600DP	9600	TSSOP8	plastic thin shrink small outline package; 8 leads; body width 3 mm	SOT505-1

4.1 Ordering options

Table 2. Ordering options

Type number	Orderable part number	Package	Packing method	Minimum order quantity	Temperature
PCA9600D	PCA9600D,118	SO8	REEL 13" Q1/T1 *STANDARD MARK SMD	2500	T _{amb} = -40 °C to +85 °C
PCA9600DP	PCA9600DP,118	TSSOP8	REEL 13" Q1/T1 *STANDARD MARK SMD	2500	T _{amb} = -40 °C to +85 °C

5. Block diagram

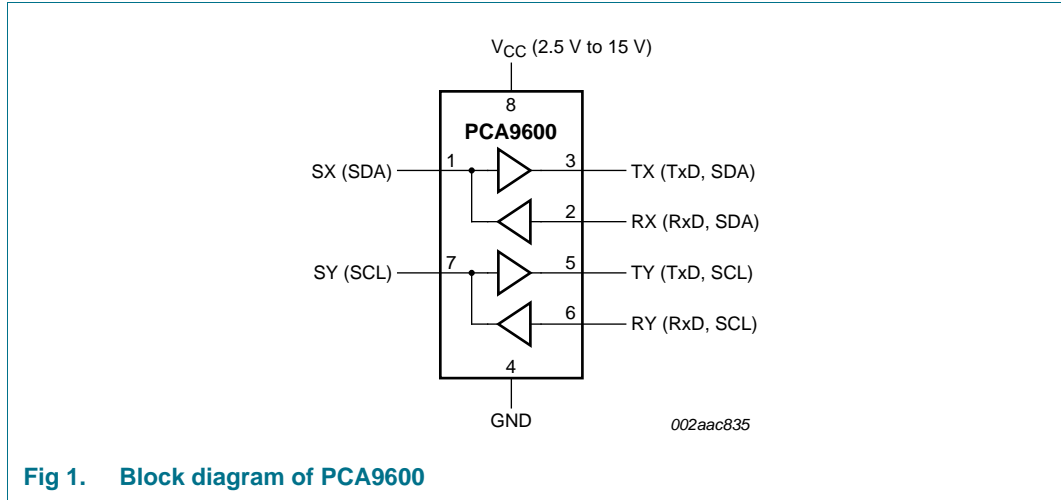

Fig 1. Block diagram of PCA9600

6. Pinning information

6.1 Pinning

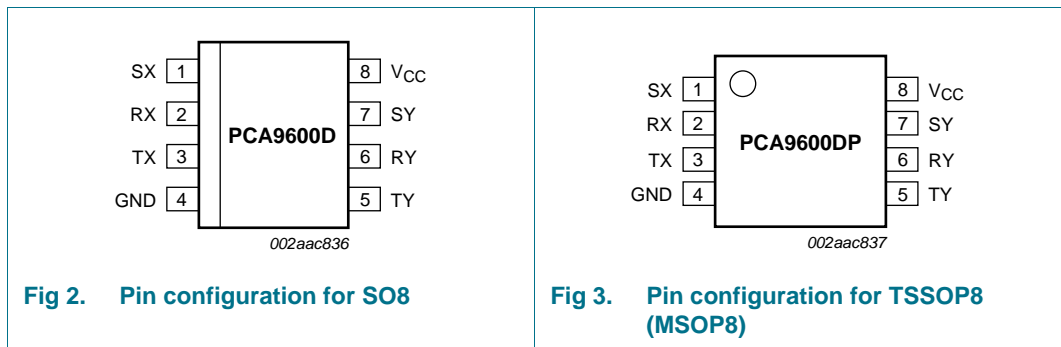

Fig 2. Pin configuration for SO8

Fig 3. Pin configuration for TSSOP8 (MSOP8)

6.2 Pin description

Table 3. Pin description

Symbol	Pin	Description
SX	1	I ² C-bus (SDA or SCL)
RX	2	receive signal
TX	3	transmit signal
GND	4	negative supply voltage
TY	5	transmit signal
RY	6	receive signal
SY	7	I ² C-bus (SDA or SCL)
V _{CC}	8	positive supply voltage

7. Functional description

Refer to [Figure 1 “Block diagram of PCA9600”](#).

The PCA9600 has two identical buffers allowing buffering of SDA and SCL I²C-bus signals. Each buffer is made up of two logic signal paths, a forward path from the I²C-bus interface, pins SX and SY which drive the buffered bus, and a reverse signal path from the buffered bus input, pins RX and RY to drive the I²C-bus interface. These paths:

- sense the voltage state of I²C-bus pins SX (and SY) and transmit this state to pin TX (and TY respectively), and
- sense the state of pins RX and RY and pull the I²C-bus pin LOW whenever pin RX or pin RY is LOW.

The rest of this discussion will address only the ‘X’ side of the buffer; the ‘Y’ side is identical.

The I²C-bus pin SX is specified to allow interfacing with Fast-mode, Fm+ and TTL-based systems.

The logic threshold voltage levels at SX on this I²C-bus are independent of the IC supply voltage V_{CC} . The maximum I²C-bus supply voltage is 15 V.

When interfacing with Fast-mode systems, the SX pin is guaranteed to sink the normal 3 mA with a V_{OL} of 0.74 V maximum. That guarantees compliance with the Fast-mode I²C-bus specification for all I²C-bus voltages greater than 3 V, as well as compliance with SMBus or other systems that use TTL switching levels.

SX is guaranteed to sink an external 3 mA in addition to its internally sourced pull-up of typically 300 μ A (maximum 1 mA at -40 °C). When selecting the pull-up for the bus at SX, the sink capability of other connected drivers should be taken into account. Most TTL devices are specified to sink at least 4 mA so then the pull-up is limited to 3 mA by the requirement to ensure the 0.8 V TTL LOW.

For Fast-mode I²C-bus operation, the other connected I²C-bus parts may have the minimum sink capability of 3 mA. SX sources typically 300 μ A (maximum 1 mA at -40 °C), which forms part of the external driver loading. When selecting the pull-up it is necessary to subtract the SX pin pull-up current, so, worst-case at -40 °C, the allowed pull-up can be limited (by external drivers) to 2 mA.

When the interface at SX is an Fm+ bus with a voltage greater than 4 V, its higher specified sink capability may be used. PCA9600 has a guaranteed sink capability of 7 mA at $V_{OL} = 1$ V maximum. That 1 V complies with the bus LOW requirement ($0.25V_{bus}$) of any Fm+ bus operating at 4 V or greater. Since the other connected Fm+ devices have a drive capability greater than 20 mA, the pull-up may be selected for 7 mA sink current at $V_{OL} = 1$ V. For a nominal 5 V bus (5.5 V maximum) the allowed pull-up is $(5.5 \text{ V} - 1 \text{ V}) / 7 \text{ mA} = 643 \Omega$. With 680 Ω pull-up, the Fm+ rise time of 120 ns maximum can be met with total bus loading up to 200 pF.

The logic level on RX is determined from the power supply voltage V_{CC} of the chip. Logic LOW is below 40 % of V_{CC} , and logic HIGH is above 55 % of V_{CC} (with a typical switching threshold just slightly below half V_{CC}).

TX is an open-collector output without ESD protection diodes to V_{CC} . It may be connected via a pull-up resistor to a supply voltage in excess of V_{CC} , as long as the 15 V rating is not exceeded. It has a larger current sinking capability than a normal I²C-bus device, being able to sink a static current of greater than 30 mA, and typical 100 mA dynamic pull-down capability as well.

A logic LOW is transmitted to TX when the voltage at I²C-bus pin SX is below 0.425 V. A logic LOW at RX will cause I²C-bus pin SX to be pulled to a logic LOW level in accordance with I²C-bus requirements (maximum 1.5 V in 5 V applications) but not low enough to be looped back to the TX output and cause the buffer to latch LOW.

The LOW level this chip can achieve on the I²C-bus by a LOW at RX is typically 0.64 V when sinking 1 mA.

If the supply voltage V_{CC} fails, then neither the I²C-bus nor the TX output will be held LOW. Their open-collector configuration allows them to be pulled up to the rated maximum of 15 V even without V_{CC} present. The input configuration on SX and RX also presents no loading of external signals when V_{CC} is not present.

The effective input capacitance of any signal pin, measured by its effect on bus rise times, is less than 10 pF for all bus voltages and supply voltages including $V_{CC} = 0$ V.

Remark: Two or more SX or SY I/Os must not be interconnected. The PCA9600 design does not support this configuration. Bidirectional I²C-bus signals do not allow any direction control pin so, instead, slightly different logic LOW voltage levels are used at SX/SY to avoid latching of this buffer. A ‘regular I²C-bus LOW’ applied at the RX/RX of a PCA9600 will be propagated to SX/SY as a ‘buffered LOW’ with a slightly higher voltage level. If this special ‘buffered LOW’ is applied to the SX/SY of another PCA9600, that second PCA9600 will not recognize it as a ‘regular I²C-bus LOW’ and will not propagate it to its TX/TX output. The SX/SY side of PCA9600 may not be connected to similar buffers that rely on special logic thresholds for their operation, for example P82B96, PCA9511A, PCA9515A, ‘B’ side of PCA9517, etc. The SX/SY side is only intended for, and compatible with, the normal I²C-bus logic voltage levels of I²C-bus master and slave chips, or even TX/RX signals of a second PCA9600 or P82B96 if required. The TX/RX and TY/RX I/O pins use the standard I²C-bus logic voltage levels of all I²C-bus parts. There are **no** restrictions on the interconnection of the TX/RX and TY/RX I/O pins to other PCA9600s, for example in a star or multipoint configuration with the TX/RX and TY/RX I/O pins on the common bus and the SX/SY side connected to the line card slave devices. For more details see *Application Note AN10658, “Sending I²C-bus signals via long communication cables”*.

The PCA9600 is a direct upgrade of the P82B96 with the significant differences summarized in [Table 4](#).

Table 4. PCA9600 versus P82B96

Detail	PCA9600	P82B96
Supply voltage (V_{CC}) range:	2.5 V to 15 V	2 V to 15 V
Maximum operating bus voltage (independent of V_{CC}):	15 V	15 V
Typical operating supply current:	5 mA	1 mA
Typical LOW-level input voltage on I ² C-bus (SX/SY side):	0.5 V over -40 °C to +85 °C	0.65 V at 25 °C

Table 4. PCA9600 versus P82B96 ...continued

Detail	PCA9600	P82B96
LOW-level output voltage on I ² C-bus (SX/SY side; 3 mA sink):	0.74 V (max.) over –40 °C to +85 °C	0.88 V (typ.) at 25 °C
LOW-level output voltage on Fm+ I ² C-bus (SX/SY side; 7 mA sink):	1 V (max.)	n/a
Temperature coefficient of V _{IL} / V _{OL} :	0 mV/°C	–2 mV/°C
Logic voltage levels on SX/SY bus (independent of V _{CC}):	compatible with I ² C-bus and similar buses using TTL levels (SMBus, etc.)	compatible with I ² C-bus and similar buses using TTL levels (SMBus, etc.)
Typical propagation delays:	< 100 ns	< 200 ns
TX/RX switching specifications (I ² C-bus compliant):	yes, all classes including 1 MHz Fm+	yes, all classes including Fm+
RX logic levels with tighter control than I ² C-bus limit of 30 % to 70 %:	yes, 40 % to 55 % (48 % nominal)	yes, 42 % to 58 % (50 % nominal)
Maximum bus speed:	> 1 MHz	> 400 kHz
ESD rating HBM per JESD22-A114:	> 3500 V	> 3500 V
Package:	SO8, TSSOP8 (MSOP8)	SO8, TSSOP8 (MSOP8)

When the device driving the PCA9600 is an I²C-bus compatible device, then the PCA9600 is an improvement on the P82B96 as shown in [Table 4](#). There will always be exceptions however, and if the device driving the bus buffer is not I²C-bus compatible (e.g., you need to use the micro already in the system and bit-bang using two GPIO pins) then here are some considerations that would point to using the P82B96 instead:

- When the pull-up must be the weakest one possible. The spec is 200 μA for P82B96, but it typically works even below that. And if designing for a temperature range –40 °C up to +60 °C, then the driver when sinking 200 μA only needs to drive a guaranteed low of 0.55 V. For the PCA9600, over that same temperature range and when sinking 1.3 mA (at –40 °C), the device driving the bus buffer must provide the required low of 0.425 V.
- When the lower operating temperature range is restricted (say 0 °C). The P82B96 larger SX voltage levels then make a better **typical** match with the driver, even when the supply is as low as 3.3 V.
For an I²C-bus compliant driver on 3.3 V the P82B96 is required to guarantee a bus low that is below 0.83 V. P82B96 guarantees that with a 200 μA pull-up.
- When the operating temperature range is restricted at both limits. An I²C driver's typical output is well below 0.4 V and the P82B96 typically requires 0.6 V input even at +60 °C, so there is a reasonable margin. The PCA9600 requires a typical input low of 0.5 V so its typical margin is smaller. At 0 °C the driver requires a typical input low of 1.16 V and P82B96 provides 0.75 V, so again the typical margin is already quite big and even though PCA9600 is better, providing 0.7 V, that difference is not big.

8. Limiting values

Table 5. Limiting values

*In accordance with the Absolute Maximum Rating System (IEC 60134).
Voltages with respect to pin GND.*

Symbol	Parameter	Conditions	Min	Max	Unit
V_{CC}	supply voltage	V_{CC} to GND	-0.3	+18	V
$V_{I2C-bus}$	I ² C-bus voltage	SX and SY; I ² C-bus SDA or SCL	-0.3	+18	V
V_O	output voltage	TX and TY; buffered output	[1] -0.3	+18	V
V_I	input voltage	RX and RY; receive input	[1] -0.3	+18	V
$I_{I2C-bus}$	I ² C-bus current	SX and SY; I ² C-bus SDA or SCL	-	250	mA
P_{tot}	total power dissipation		-	300	mW
T_j	junction temperature	operating range	-40	+125	°C
T_{stg}	storage temperature		-55	+125	°C
T_{amb}	ambient temperature	operating	-40	+85	°C

[1] See also [Section 10.2 "Negative undershoot below absolute minimum value"](#).

9. Characteristics

Table 6. Characteristics

$T_{amb} = -40\text{ °C}$ to $+85\text{ °C}$ unless otherwise specified; voltages are specified with respect to GND with $V_{CC} = 2.5\text{ V}$ to 15 V unless otherwise specified. Typical values are measured at $V_{CC} = 5\text{ V}$ and $T_{amb} = 25\text{ °C}$.

Symbol	Parameter	Conditions	Min	Typ	Max	Unit
Power supply						
V_{CC}	supply voltage	operating	2.5	-	15	V
I_{CC}	supply current	$V_{CC} = 5\text{ V}$; buses HIGH	-	5.2	6.75	mA
		$V_{CC} = 15\text{ V}$; buses HIGH	-	5.5	7.3	mA
ΔI_{CC}	additional supply current	per TX/TY output driven LOW; $V_{CC} = 5.5\text{ V}$	-	1.4	3.0	mA
Bus pull-up (load) voltages and currents						
Pins SX and SY; I²C-bus						
V_I	input voltage	open-collector; RX and RY HIGH	-	-	15	V
V_O	output voltage	open-collector; RX and RY HIGH	-	-	15	V
I_O	output current	static; $V_{SX} = V_{SY} = 0.4\text{ V}$	[1] 0.3	-	2	mA
$I_{O(sink)}$	output sink current	dynamic; $V_{SX} = V_{SY} = 1\text{ V}$; RX and RY LOW	7	15	-	mA
I_L	leakage current	$V_{SX} = V_{SY} = 15\text{ V}$; RX and RY HIGH	-	-	10	μA
Pins TX and TY						
V_O	output voltage	open-collector	-	-	15	V
I_{load}	load current	maximum recommended on buffered bus; $V_{TX} = V_{TY} = 0.4\text{ V}$; SX and SY LOW on I ² C-bus = 0.4 V	-	-	30	mA
I_O	output current	from buffered bus; $V_{TX} = V_{TY} = 1\text{ V}$; SX and SY LOW on I ² C-bus = 0.4 V	60	130	-	mA
I_L	leakage current	on buffered bus; $V_{TX} = V_{TY} = V_{CC} = 15\text{ V}$; SX and SY HIGH	-	-	10	μA
Input currents						
I_I	input current	from I ² C-bus on SX and SY				
		RX and RY HIGH or LOW; SX and SY LOW $\leq 1\text{ V}$	[1] -	-0.3	-1	mA
		RX and RY HIGH; SX and SY HIGH $> 1.4\text{ V}$	[1] -	-	10	μA
I_L	leakage current	from buffered bus on RX and RY; SX and SY HIGH or LOW; $V_{RX} = V_{RY} = 0.4\text{ V}$	[2] -	-1.5	-10	μA
		on buffered bus input on RX and RY; $V_{RX} = V_{RY} = 15\text{ V}$	-	-	10	μA

Table 6. Characteristics ...continued

$T_{amb} = -40\text{ °C}$ to $+85\text{ °C}$ unless otherwise specified; voltages are specified with respect to GND with $V_{CC} = 2.5\text{ V}$ to 15 V unless otherwise specified. Typical values are measured at $V_{CC} = 5\text{ V}$ and $T_{amb} = 25\text{ °C}$.

Symbol	Parameter	Conditions	Min	Typ	Max	Unit
Output logic LOW level						
Pins SX and SY						
V_{OL}	LOW-level output voltage	on Standard-mode or Fast-mode I ² C-bus				
		$I_{SX} = I_{SY} = 3\text{ mA}$; Figure 6	-	0.7	0.74	V
		$I_{SX} = I_{SY} = 0.3\text{ mA}$; Figure 5	-	0.6	0.65	V
		on 5 V Fm+ I ² C-bus				
		$I_{SX} = I_{SY} = 7\text{ mA}$	-	-	1	V
$\Delta V/\Delta T$	voltage variation with temperature	$I_{SX} = I_{SY} = 0.3\text{ mA}$ to 3 mA	-	0	-	%/K
Input logic switching threshold voltages						
Pins SX and SY						
V_{IL}	LOW-level input voltage	on normal I ² C-bus; Figure 7	[3] -	-	425	mV
$V_{th(IH)}$	HIGH-level input threshold voltage	on normal I ² C-bus; Figure 8	580	-	-	mV
$\Delta V/\Delta T$	voltage variation with temperature		-	0	-	%/K
Pins RX and RY						
V_{IH}	HIGH-level input voltage	fraction of applied V_{CC}	$0.55V_{CC}$	-	-	V
$V_{th(i)}$	input threshold voltage	fraction of applied V_{CC}	-	$0.48V_{CC}$	-	V
V_{IL}	LOW-level input voltage	fraction of applied V_{CC}	-	-	$0.4V_{CC}$	V
Logic level threshold difference						
ΔV	voltage difference	SX and SY; SX output LOW at 0.3 mA to SX input HIGH maximum	[4] 50	-	-	mV
Thermal resistance						
$R_{th(j-pcb)}$	thermal resistance from junction to printed-circuit board	SOT96-1 (SO8); average lead temperature at board interface	-	127	-	K/W
Bus release on V_{CC} failure						
V_{CC}	supply voltage	SX, SY, TX and TY; voltage at which all buses are to be released at 25 °C	-	-	1	V
$\Delta V/\Delta T$	voltage variation with temperature	Figure 9	-	-4	-	%/K

Table 6. Characteristics ...continued

$T_{amb} = -40\text{ }^{\circ}\text{C}$ to $+85\text{ }^{\circ}\text{C}$ unless otherwise specified; voltages are specified with respect to GND with $V_{CC} = 2.5\text{ V}$ to 15 V unless otherwise specified. Typical values are measured at $V_{CC} = 5\text{ V}$ and $T_{amb} = 25\text{ }^{\circ}\text{C}$.

Symbol	Parameter	Conditions	Min	Typ	Max	Unit
Buffer response time^[5]						
$V_{CC} = 5\text{ V}$; pin TX pull-up resistor = $160\text{ }\Omega$; pin SX pull-up resistor = $2.2\text{ k}\Omega$; no capacitive load						
t_d	delay time	V_{SX} to V_{TX} , V_{SY} to V_{TY} ; on falling input between $V_{SX} =$ input switching threshold, and V_{TX} output falling to 50 % V_{CC}	-	50	-	ns
		V_{SX} to V_{TX} , V_{SY} to V_{TY} ; on rising input between $V_{SX} =$ input switching threshold, and V_{TX} output reaching 50 % V_{CC}	-	60	-	ns
		V_{RX} to V_{SX} , V_{RY} to V_{SY} ; on falling input between $V_{RX} =$ input switching threshold, and V_{SX} output falling to 50 % V_{CC}	-	100	-	ns
		V_{RX} to V_{SX} , V_{RY} to V_{SY} ; on rising input between $V_{RX} =$ input switching threshold, and V_{SX} output reaching 50 % V_{CC}	-	95	-	ns
Input capacitance						
C_i	input capacitance	effective input capacitance of any signal pin measured by incremental bus rise times; guaranteed by design, not production tested	-	-	10	pF

- [1] This bus pull-up current specification is intended to assist design of the bus pull-up resistor. It is not a specification of the sink capability (see V_{OL} under sub-section "Output logic LOW level"). The maximum static sink current for a Standard/Fast-mode I²C-bus is 3 mA and PCA9600 is guaranteed to sink 3 mA at SX/SY when its pins are holding the bus LOW. However, when an external device pulls the SX/SY pins below 1.4 V, the PCA9600 may source a current between 0 mA and 1 mA maximum. When that other external device is driving LOW it will pull the bus connected to SX or SY down to, or below, the 0.4 V level referenced in the I²C-bus specification and in these test conditions. Then that device must be able to sink up to 1 mA coming from SX/SY plus the usual pull-up current. Therefore the external pull-up used at SX/SY should be limited to 2 mA. The typical and maximum currents sourced by SX/SY as a function of junction temperature are shown in [Figure 10](#), and the equivalent circuit at the SX/SY interface is shown in [Figure 4](#).
- [2] Valid over temperature for $V_{CC} \leq 5\text{ V}$. At higher V_{CC} , this current may increase to maximum $-20\text{ }\mu\text{A}$ at $V_{CC} = 15\text{ V}$.
- [3] The input logic threshold is independent of the supply voltage.
- [4] The minimum value requirement for pull-up current, 0.3 mA, guarantees that the minimum value for V_{SX} output LOW will always exceed the maximum V_{SX} input HIGH level to eliminate any possibility of latching. The specified difference is guaranteed by design within any IC. While the tolerances on absolute levels allow a small probability, the LOW from one SX output is recognized by an SX input of another PCA9600, this has no consequences for normal applications. In any design the SX pins of different ICs should never be linked because the resulting system would be very susceptible to induced noise and would not support all I²C-bus operating modes.
- [5] The fall time of V_{TX} from 5 V to 2.5 V in the test is approximately 10 ns.
The fall time of V_{SX} from 5 V to 2.5 V in the test is approximately 20 ns.
The rise time of V_{TX} from 0 V to 2.5 V in the test is approximately 15 ns.
The rise time of V_{SX} from 0.7 V to 2.5 V in the test is approximately 25 ns.

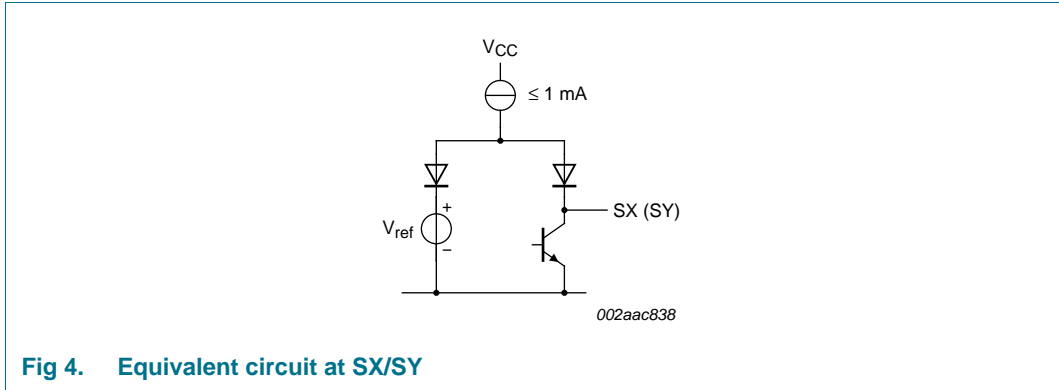
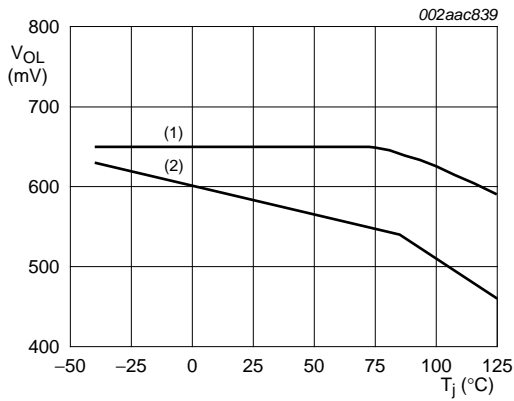

Fig 4. Equivalent circuit at SX/SY



V_{OL} at SX typical and limits over temperature.

- (1) Maximum.
- (2) Typical.

Fig 5. V_{OL} as a function of junction temperature ($I_{OL} = 0.3 \text{ mA}$)

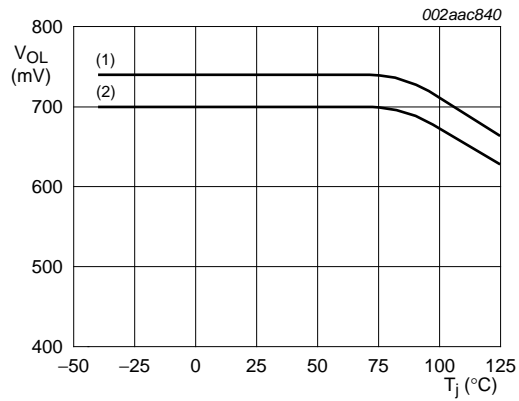

V_{OL} at SX typical and limits over temperature.

- (1) Maximum.
- (2) Typical.

Fig 6. V_{OL} as a function of junction temperature ($I_{OL} = 3 \text{ mA}$)

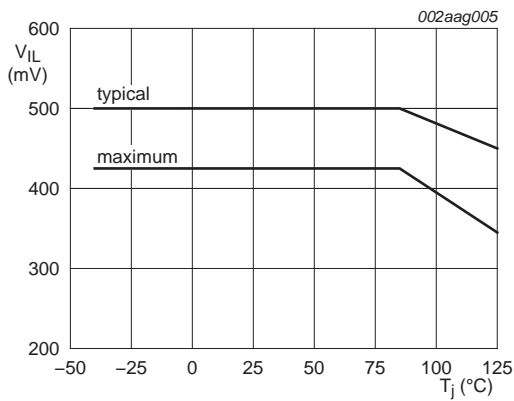

V_{IL} at SX changes over temperature range.

Fig 7. V_{IL} as a function of junction temperature; maximum and typical values

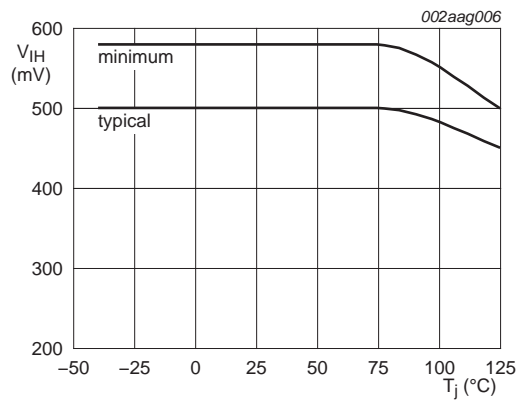

V_{IH} at SX changes over temperature range.

Fig 8. V_{IH} as a function of junction temperature; minimum and typical values

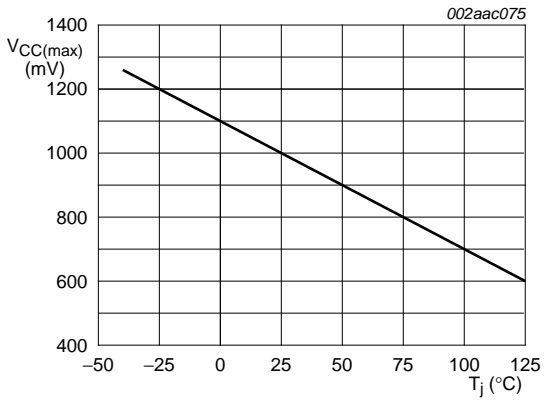
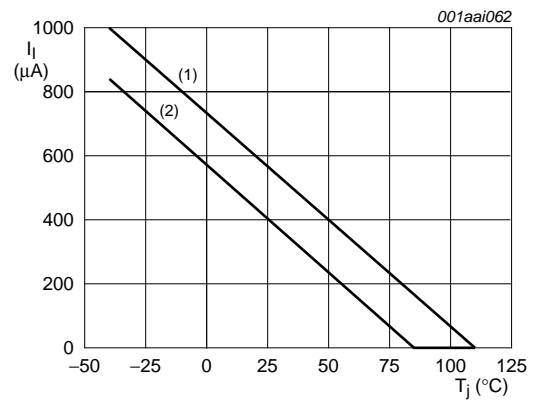

Fig 9. V_{CC} bus release limit over temperature; maximum values



- (1) Maximum.
- (2) Typical.

Fig 10. Current sourced out of SX/SY as a function of junction temperature if these pins are externally pulled to 0.4 V or lower

10. Application information

Refer to PCA9600 data sheet and application notes AN10658 and AN255 for more detailed application information.

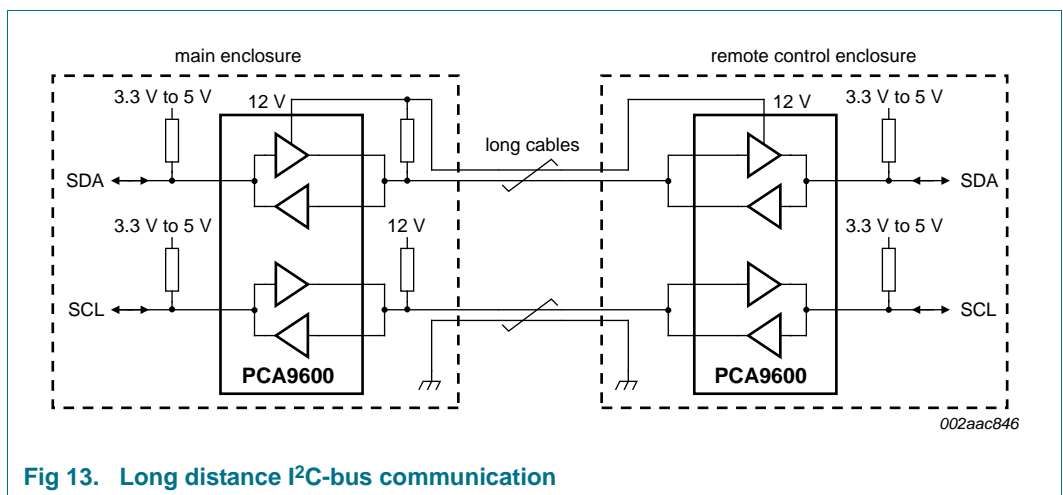
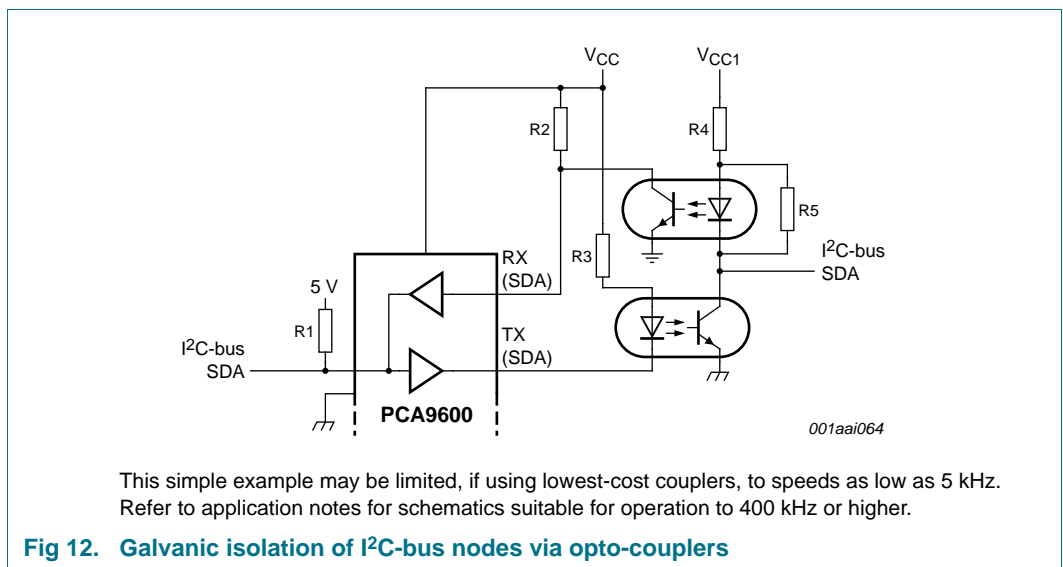
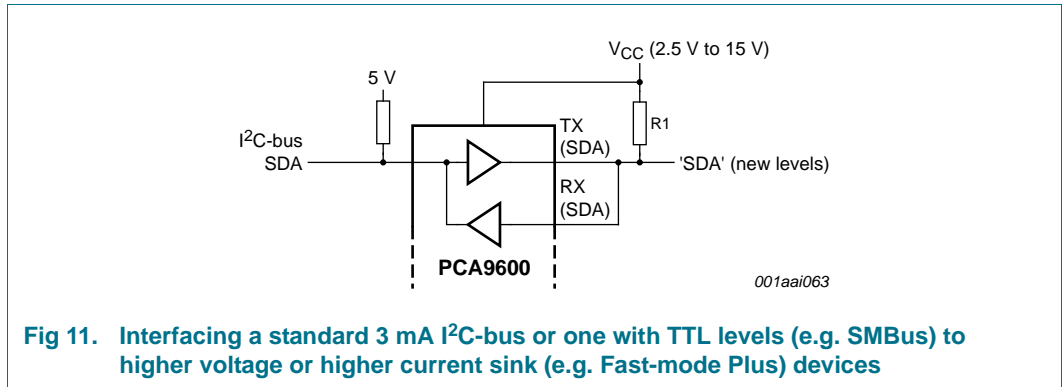

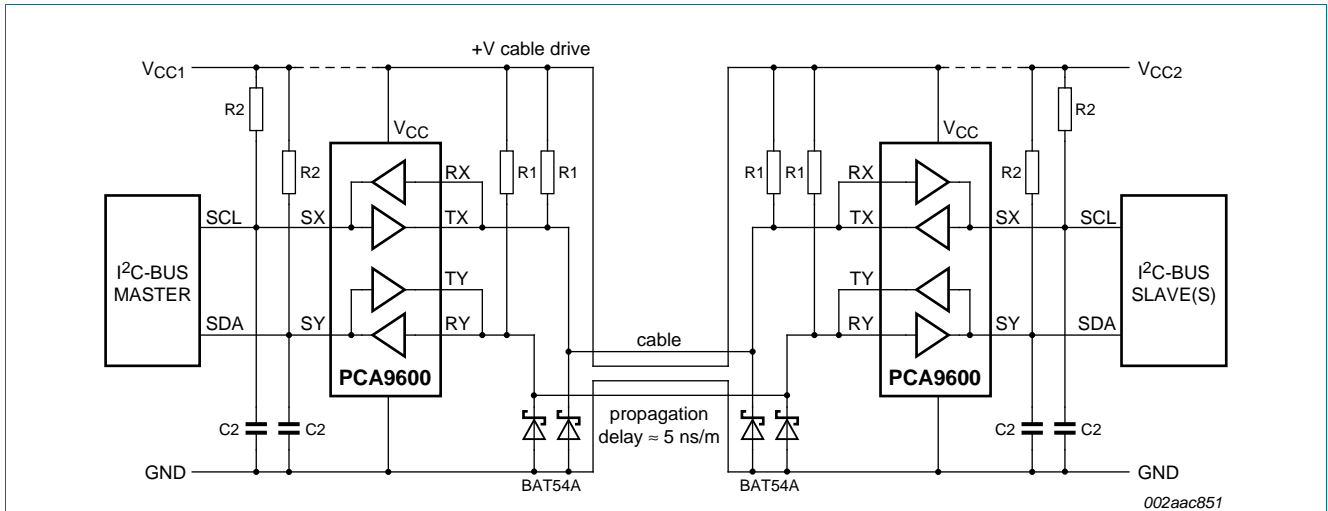

Fig 14. Driving ribbon or flat telephone cables

Table 7. Examples of bus capability

Refer to Figure 14.

V _{CC1} (V)	+V cable (V)	V _{CC2} (V)	R1 (Ω)	R2 (kΩ)	C2 (pF)	Cable length (m)	Cable capacitance	Cable delay	Set master nominal SCL		Effective bus clock speed (kHz)	Max. slave response delay
									HIGH period (ns)	LOW period (ns)		
5	12	5	750	2.2	400	250	n/a (delay based)	1.25 μs	600	3850	125	normal specification 400 kHz parts
5	12	5	750	2.2	220	100	n/a (delay based)	500 ns	600	2450	195	normal specification 400 kHz parts
3.3	5	3.3	330	1	220	25	1 nF	125 ns	260	770	620	meets Fm+ specification
3.3	5	3.3	330	1	100	3	120 pF	15 ns	260	720	690	meets Fm+ specification

For more examples of faster alternatives for driving over longer cables such as Cat5 communication cable, see AN10658. Communication at 1 MHz is possible over short cables and > 400 kHz is possible over 50 m of cable.

10.1 Calculating system delays and bus clock frequency

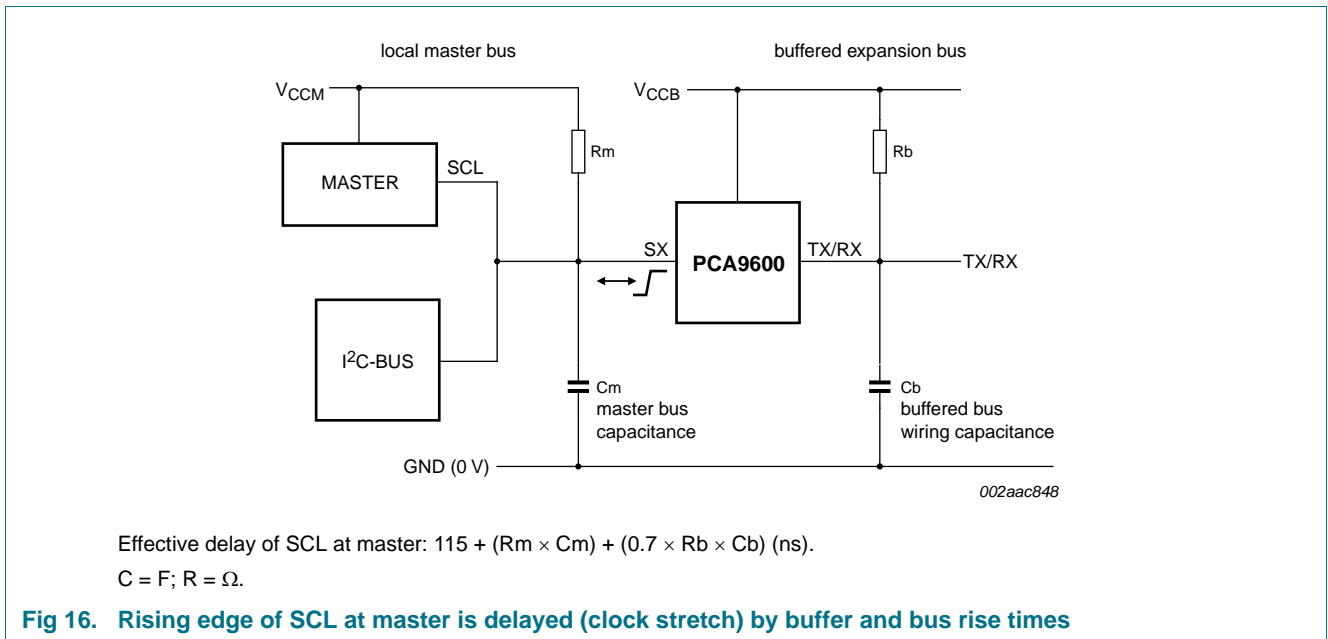
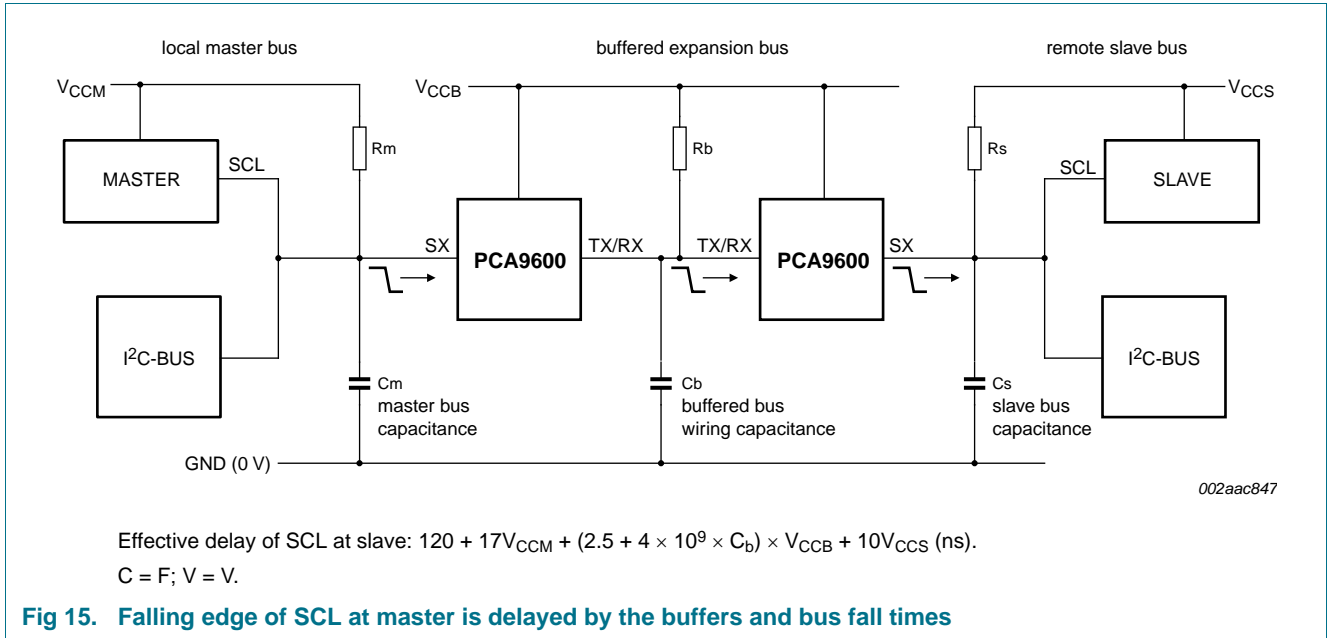

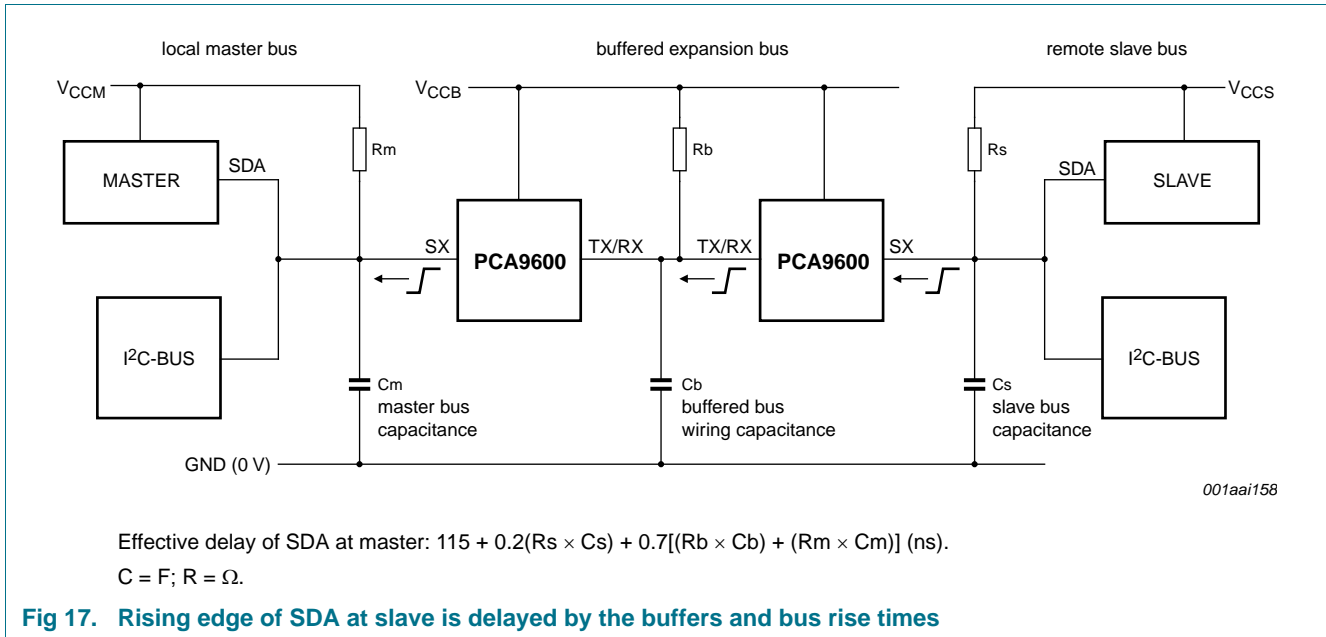

Figure 15, Figure 16, and Figure 17 show the PCA9600 used to drive extended bus wiring with relatively large capacitances linking two I²C-bus nodes. It includes simplified expressions for making the relevant timing calculations for 3.3 V or 5 V operation. Because the buffers and the wiring introduce timing delays, it may be necessary to decrease the nominal SCL frequency. In most cases the actual bus frequency will be lower than the nominal Master timing due to bit-wise stretching of the clock periods.

The delay factors involved in calculation of the allowed bus speed are:

- A** — The propagation delay of the master signal through the buffers and wiring to the slave. The important delay is that of the falling edge of SCL because this edge ‘requests’ the data or acknowledgment from a slave. See Figure 15.
- B** — The effective stretching of the nominal LOW period of SCL at the master caused by the buffer and bus rise times. See Figure 16.
- C** — The propagation delay of the slave’s response signal through the buffers and wiring back to the master. The important delay is that of a rising edge in the SDA signal. Rising edges are always slower and are therefore delayed by a longer time than falling edges. (The rising edges are limited by the passive pull-up while falling edges are actively driven); see Figure 17.

The timing requirement in any I²C-bus system is that a slave’s data response (which is provided in response to a falling edge of SCL) must be received at the master before the end of the corresponding LOW period of SCL as appears on the bus wiring at the master. Since all slaves will, as a minimum, satisfy the worst case timing requirements of their speed class (Fast-mode, Fm+, etc.), they must provide their response, allowing for the set-up time, within the minimum allowed clock LOW period, e.g., 450 ns (max.) for Fm+ parts. In systems that introduce additional delays it may be necessary to extend the minimum clock LOW period to accommodate the ‘effective’ delay of the slave’s response. The effective delay of the slave’s response equals the total delays in SCL falling edge from the master reaching the slave (Figure 15) minus the effective delay (stretch) of the SCL rising edge (Figure 16) plus total delays in the slave’s response data, carried on

SDA, reaching the master ([Figure 17](#)).

The master microcontroller should be programmed to produce a nominal SCL LOW period as follows:

$$SCL\ LOW \geq (\text{slave response delay to valid data on its SDA} + A - B + C + \text{data set-up time})\ ns \quad (1)$$

The actual LOW period will become (the programmed value + the stretching time B). When this actual LOW period is then less than the specified minimum, the specified minimum should be used.

Example 1:

It is required to connect an Fm+ slave, with $R_s \times C_s$ product of 100 ns, to a 5 V Fast-mode system also having 100 ns $R_m \times C_m$ using two PCA9600's to buffer a 5 V bus with 4 nF loading and 160 Ω pull-up.

Calculate the allowed bus speed:

$$\text{Delay A} = 120 + 85 + (2.5 + [4 \times 4]) \times 5 + 50 = 347.5\ ns$$

$$\text{Delay B} = 115 + 100 + 70 = 285\ ns$$

$$\text{Delay C} = 115 + 20 + 0.7(100 + 100) = 275\ ns$$

The maximum Fm+ slave response delay must be < 450 ns so the programmed LOW period is calculated as:

$$LOW \geq 450 + 347.5 - 285 + 275 + 100 = 887.5\ ns$$

The actual LOW period will be $887.5 + 285 = 1173\ ns$, which is below the Fast-mode minimum, so the programmed LOW period must be increased to $(1300 - 285) = 1015\ ns$, so the actual LOW equals the 1300 ns requirement and this shows that this Fast-mode system may be safely run to its limit of 400 kHz.

Example 2:

It is required to buffer a Master with Fm+ speed capability, but only 3 mA sink capability, to an Fm+ bus. All the system operates at 3.3 V. The Master $R_m \times C_m$ product is 50 ns. Only one PCA9600 is used. The Fm+ bus becomes the buffered bus. The Fm+ bus has 200 pF loading and 150 Ω pull-up, so its $R_b \times C_b$ product is 30 ns. The Fm+ slave has a specified data valid time $t_{VD, DAT}$ maximum of 300 ns.

Calculate the allowed maximum system bus speed. (Note that the fixed values in the delay equations represent the internal propagation delays of the PCA9600. Only one PCA9600 is used here, so those fixed values used below are taken from the characteristics.)

The delays are:

$$\text{Delay A} = 40 + 56 + (2.5 + [4 \times 0.2]) \times 3.3 = 107\ ns$$

$$\text{Delay B} = 115 + 50 + 21 = 186\ ns$$

$$\text{Delay C} = 70 + 0.7(50 + 30) = 126\ ns$$

The programmed LOW period is calculated as:

$$SCL\ LOW \geq 300 + 117 - 186 + 126 + 50 = 407\ ns$$

The actual LOW period will be $407 + 126 = 533\ ns$, which exceeds the minimum Fm+ 500 ns requirement. This system requires the bus LOW period, and therefore cycle time, to be increased by 33 ns so the system must run slightly below the 1 MHz limit.

The possible maximum speed has a cycle period of 1033 ns or 968 kHz.

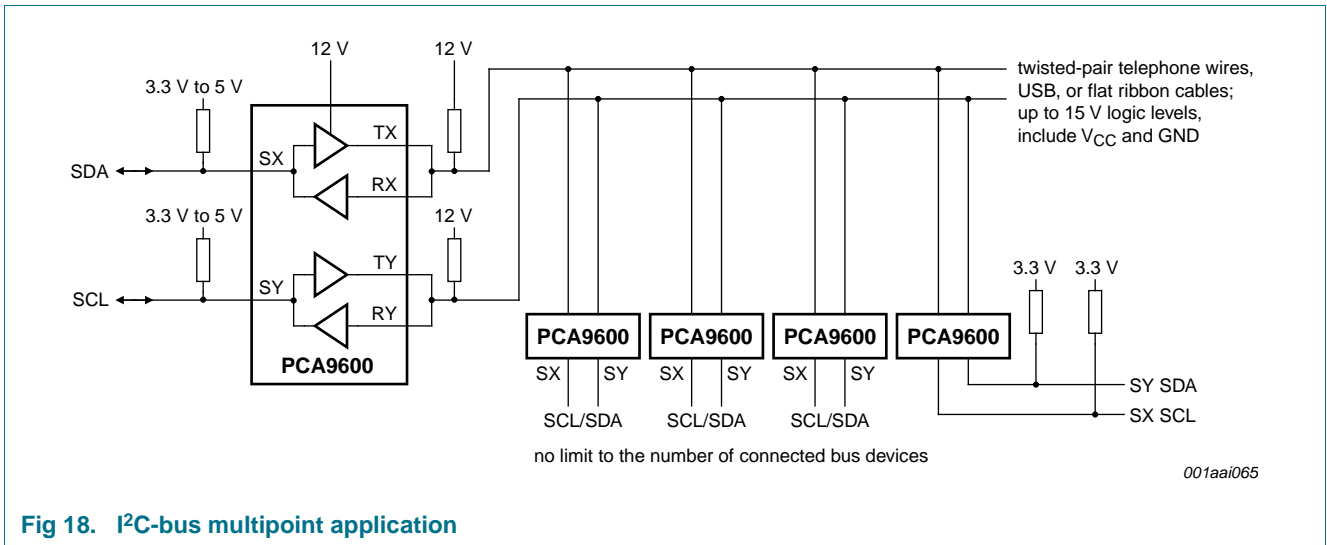
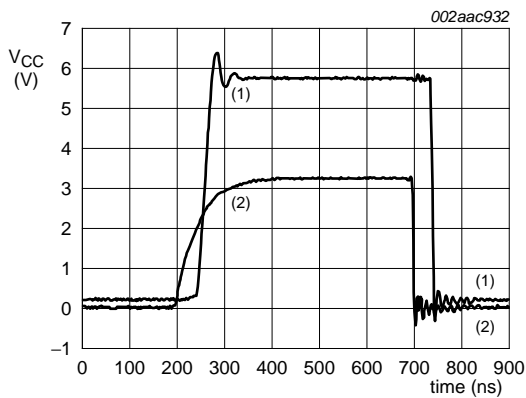

Fig 18. I²C-bus multipoint application

There is an Excel calculator which makes it easy to determine the maximum I²C-bus clock speed when using the PCA9600. The calculator and instructions can be found at www.nxp.com/clockspeedcalculator.



- (1) TX output.
- (2) SX input.

Fig 19. Propagation SX to TX with $V_{RX} = V_{CC} = 3.3\text{ V}$ (SX pull-up to 3.3 V; TX pull-up to 5.7 V)

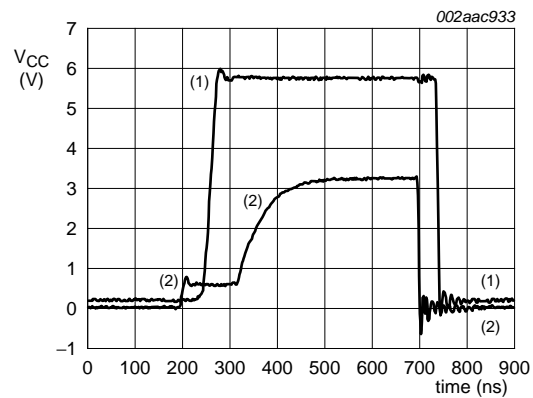

- (1) TX/RX output.
- (2) SX input.

Fig 20. Propagation SX to TX with RX tied to TX; $V_{CC} = 3.3\text{ V}$ (SX pull-up to 3.3 V; TX pull-up to 5.7 V)

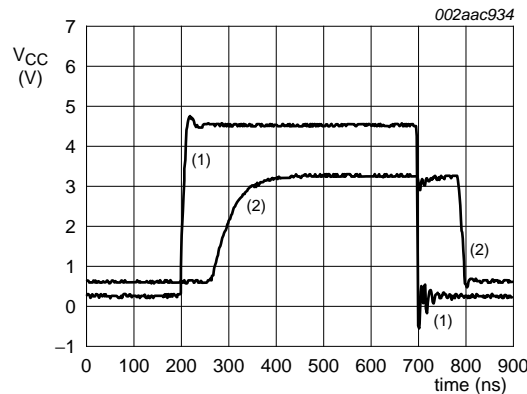

- (1) RX input.
- (2) SX output.

Fig 21. Propagation RX to SX (SX pull-up to 3.3 V; $V_{CC} = 3.3\text{ V}$; RX pull-up to 4.6 V)

10.2 Negative undershoot below absolute minimum value

The reason why the IC pin reverse voltage on pins TX and RX in [Table 5 "Limiting values"](#) is specified at such a low value, -0.3 V , is **not** that applying larger voltages is likely to cause damage but that it is expected that, in normal applications, there is no reason why larger DC voltages will be applied. This 'absolute maximum' specification is intended to be a DC or continuous ratings and the nominal DC I²C-bus voltage LOW usually does not even reach 0 V. Inside PCA9600 at every pin there is a large protective diode connected to the GND pin and that diode will start to conduct when the pin voltage is more than about -0.55 V with respect to GND at 25 °C ambient.

[Figure 22](#) shows the measured characteristic for one of those diodes inside PCA9600. The plot was made using a curve tracer that applies 50 Hz mains voltage via a series resistor, so the pulse durations are long duration (several milliseconds) and are reaching peaks of over 2 A when more than -1.5 V is applied. The IC becomes very hot during this

testing but it was not damaged. Whenever there is current flowing in any of these diodes it is **possible** that there can be faulty operation of any IC. For that reason we put a specification on the negative voltage that is allowed to be applied. It is selected so that, at the highest allowed junction temperature, there will be a big safety factor that guarantees the diode will not conduct and then we do not need to make any 100 % production tests to guarantee the published specification.

For the PCA9600, in specific applications, there will always be transient overshoot and ringing on the wiring that can cause these diodes to conduct. Therefore we designed the IC to withstand those transients and as a part of the qualification procedure we made tests, using DC currents to more than twice the normal bus sink currents, to be sure that the IC was not affected by those currents. For example, the TX/TY and RX/RX pins were tested to at least -80 mA which, from [Figure 22](#), would be more than -0.8 V. The correct functioning of the PCA9600 is not affected even by those large currents. The Absolute Maximum (DC) ratings are not intended to apply to transients but to steady state conditions. This explains why you will never see any problems in practice even if, during transients, more than -0.3 V is applied to the bus interface pins of PCA9600.

[Figure 22 "Diode characteristic curve"](#) also explains how the general Absolute Maximum DC specification was selected. The current at 25 °C is near zero at -0.55 V. The PCA9600 is allowed to operate with +125 °C junction and that would cause this diode voltage to decrease by $100 \times 2 \text{ mV} = 200 \text{ mV}$. So for zero current we need to specify -0.35 V and we publish -0.3 V just to have some extra margin.

Remark: You should not be concerned about the **transients** generated on the wiring by a PCA9600 in normal applications and that is input to the TX/RX or TY/RX pins of another PCA9600. Because not all ICs that may be driven by PCA9600 are designed to tolerate negative transients, in [Section 10.2.1 "Example with questions and answers"](#) we show they can be managed if required.

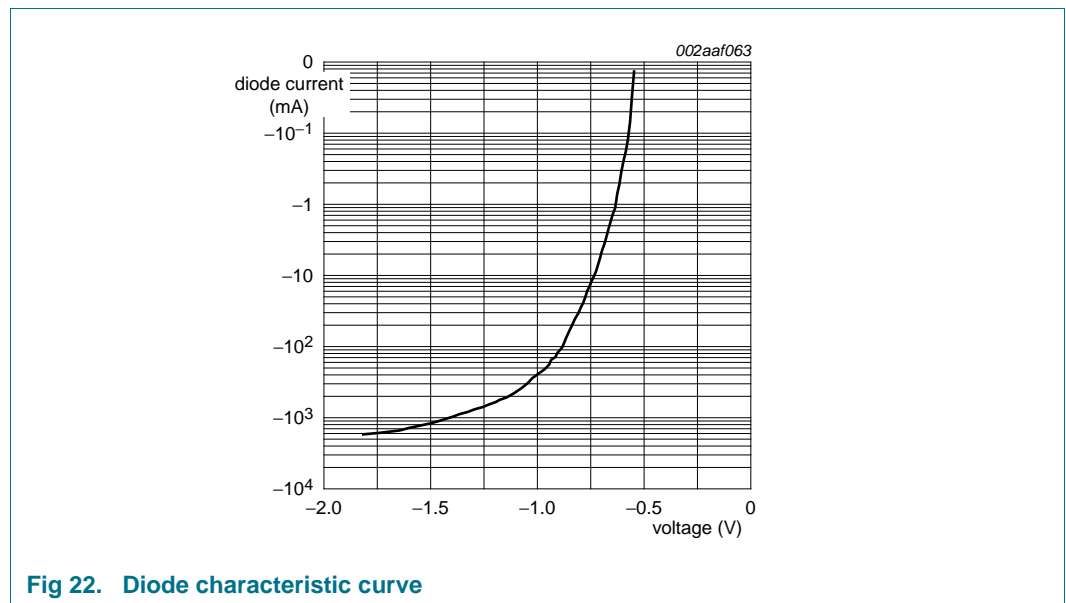

Fig 22. Diode characteristic curve

10.2.1 Example with questions and answers

Question: On a falling edge of TX we measure undershoot at -800 mV at the linked TX, RX pins of the PCA9600 that is generating the LOW, but the PCA9600 data sheet specifies minimum -0.3 V. Does this mean that we violate the data sheet absolute value?

Answer: For PCA9600 the -0.3 V Absolute Maximum rating is not intended to apply to transients, it is a DC rating. As shown in Figure 23, there is no theoretical reason for any undershoot at the IC that is driving the bus LOW and no significant undershoot should be observed when using reasonable care with the ground connection of the 'scope. It is more likely that undershoot observed at a driving PCA9600 is caused by local stray inductance and capacitance in the circuit and by the oscilloscope connections. As shown, undershoot will be generated by PCB traces, wiring, or cables driven by a PCA9600 because the allowed value of the I²C-bus pull-up resistor generally is larger than that required to correctly terminate the wiring. In this example, with no IC connected at the end of the wiring, the undershoot is about 2 V.

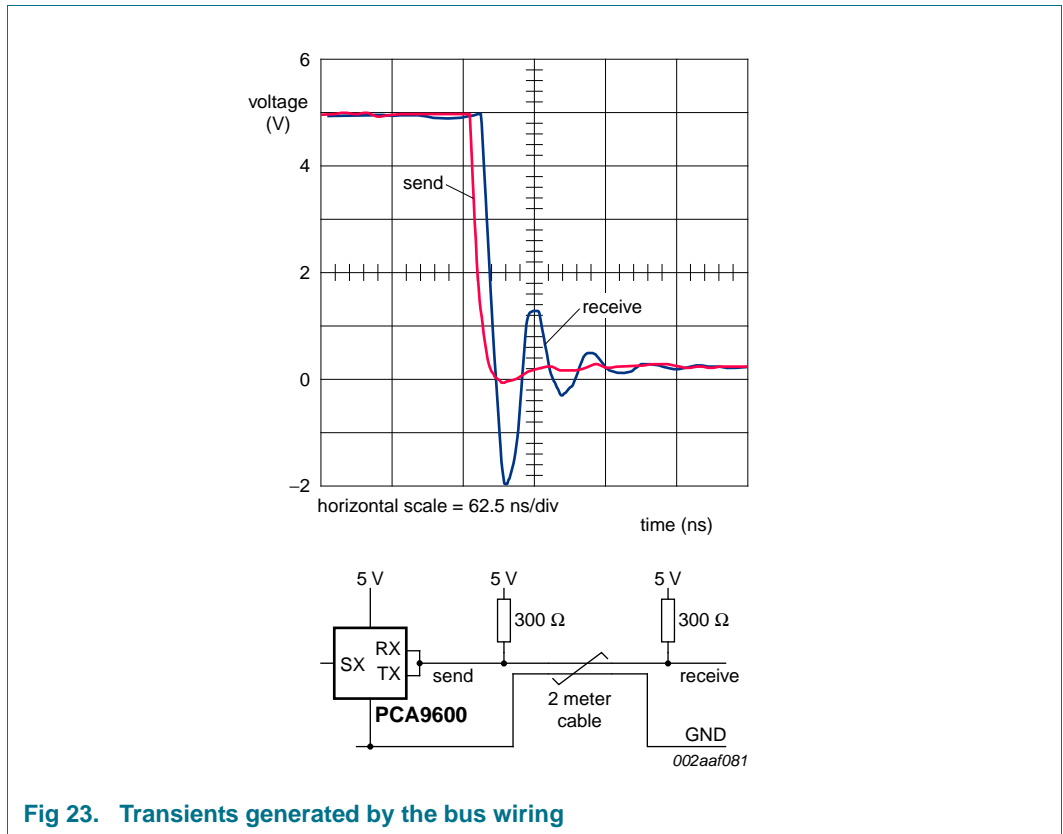

Fig 23. Transients generated by the bus wiring

Question: We have 2 meters of cable in a bus that joins the TX/RX sides of two PCA9600 devices. When one TX drives LOW the other PCA9600 TX/RX is driven to -0.8 V for over 50 ns. What is the expected value and the theoretically allowed value of undershoot?

Answer: Because the cable joining the two PCA9600s is a 'transmission line' that will have a characteristic impedance around $100\ \Omega$ and it will be terminated by pull-up resistors that are larger than that characteristic impedance there will always be negative undershoot generated. The duration of the undershoot is a function of the cable length and the input impedance of the connected IC. As shown in [Figure 24](#), the transient undershoot will be limited, by the diodes inside PCA9600, to around -0.8 V and that will not cause problems for PCA9600. Those transients will **not** be passed inside the IC to the SX/SY side of the IC.

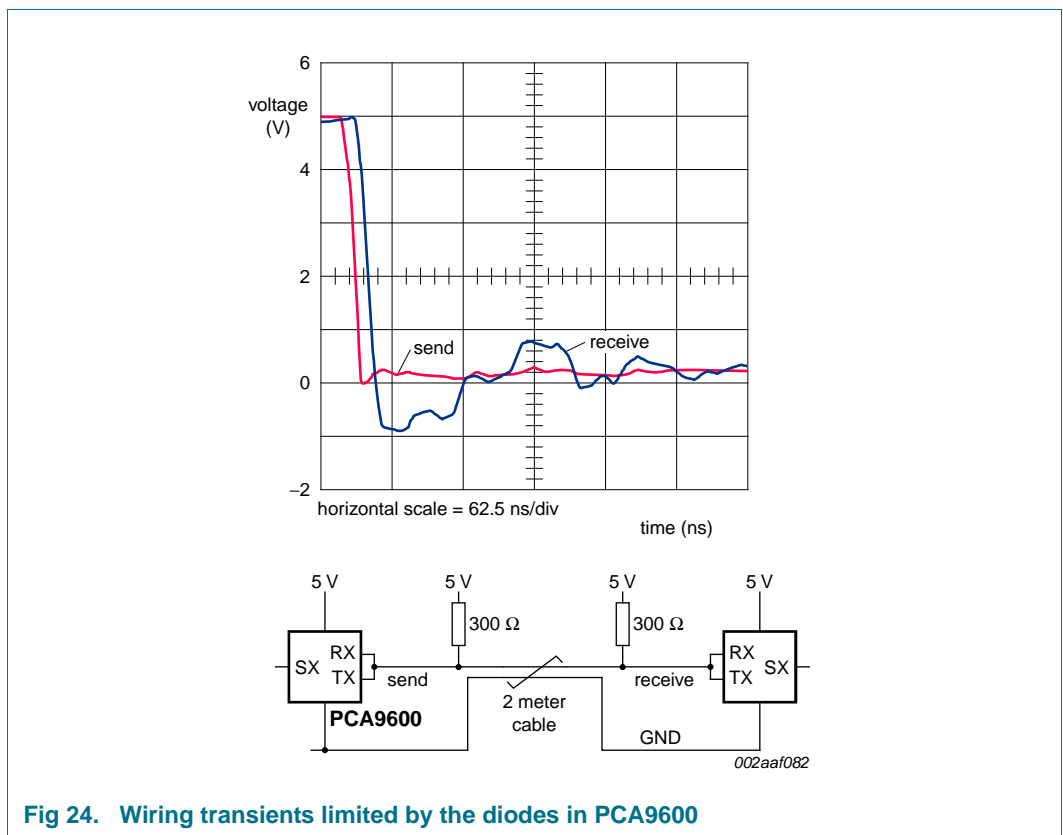

Fig 24. Wiring transients limited by the diodes in PCA9600

Question: If we input 800 mV undershoot at TX, RX pins, what kind of problem is expected?

Answer: When that undershoot is generated by another PCA9600 and is simply the result of the system wiring, then there will be no problems.

Question: Will we have any functional problem or reliability problem?

Answer: No.

Question: If we add 100 Ω to 200 Ω at signal line, the overshoot becomes slightly smaller. Is this a good idea?

Answer: No, it is not necessary to add any resistance. When the logic signal generated by TX or TY of PCA9600 drives long traces or wiring with ICs other than PCA9600 being driven, then adding a Schottky diode (BAT54A) as shown in [Figure 25](#) will clamp the wiring undershoot to a value that will not cause conduction of the IC's internal diodes.

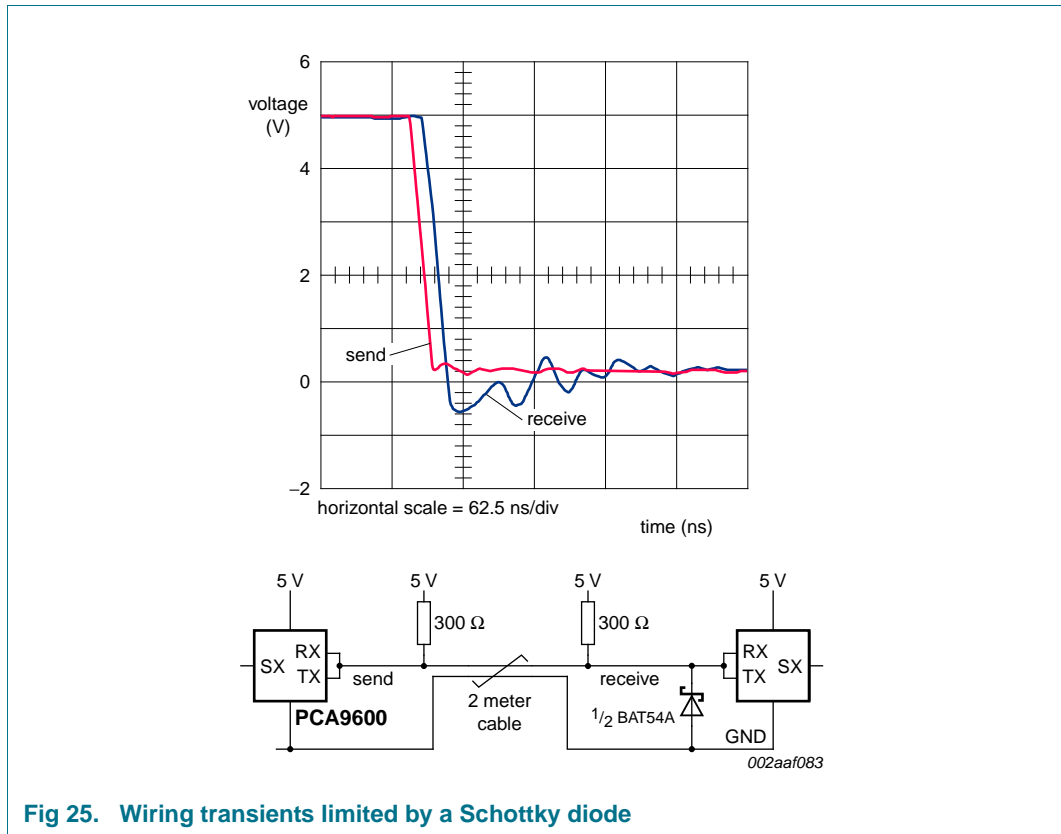

11. Package outline

SO8: plastic small outline package; 8 leads; body width 3.9 mm

SOT96-1

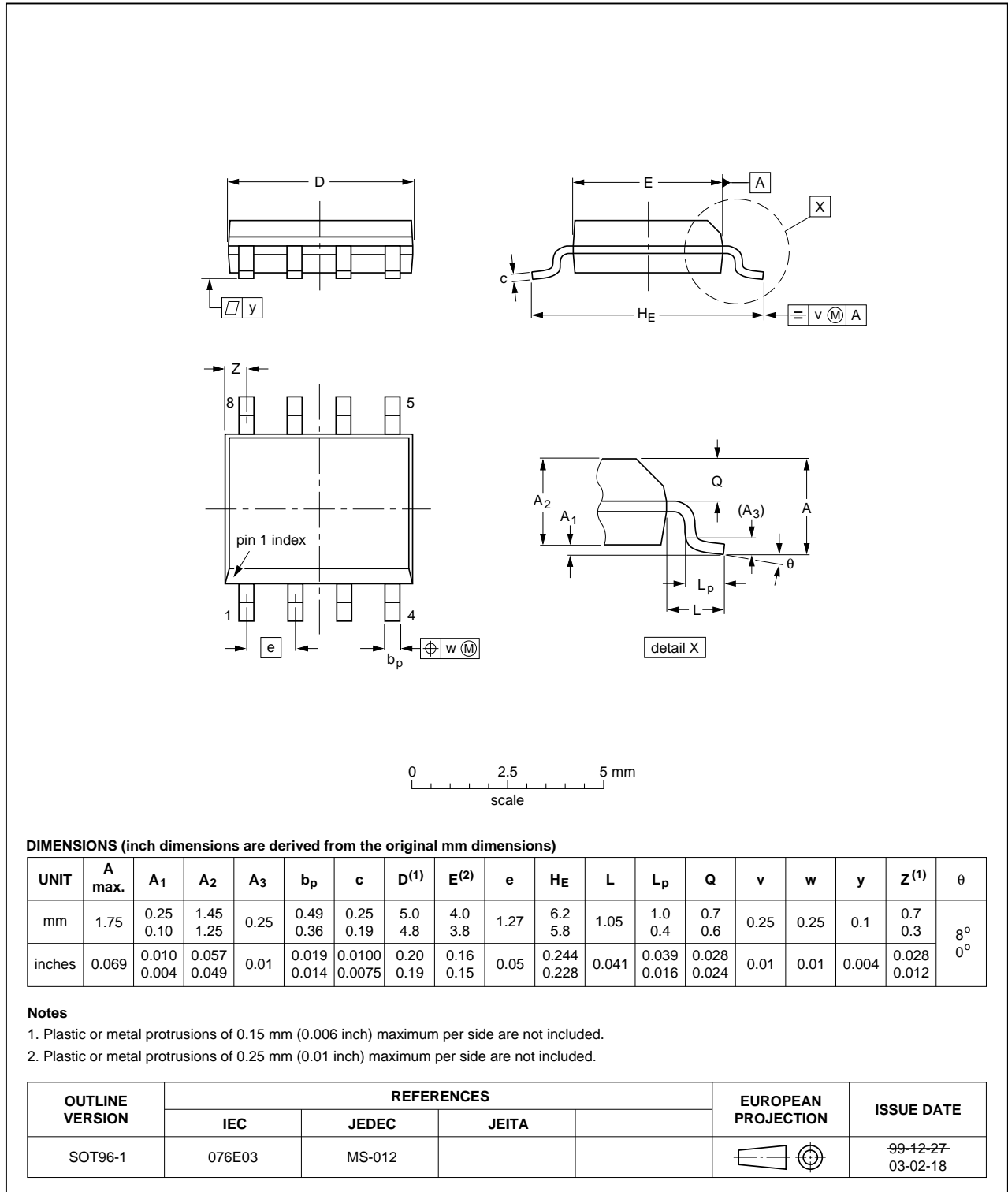

Fig 26. Package outline SOT96-1 (SO8)

TSSOP8: plastic thin shrink small outline package; 8 leads; body width 3 mm

SOT505-1

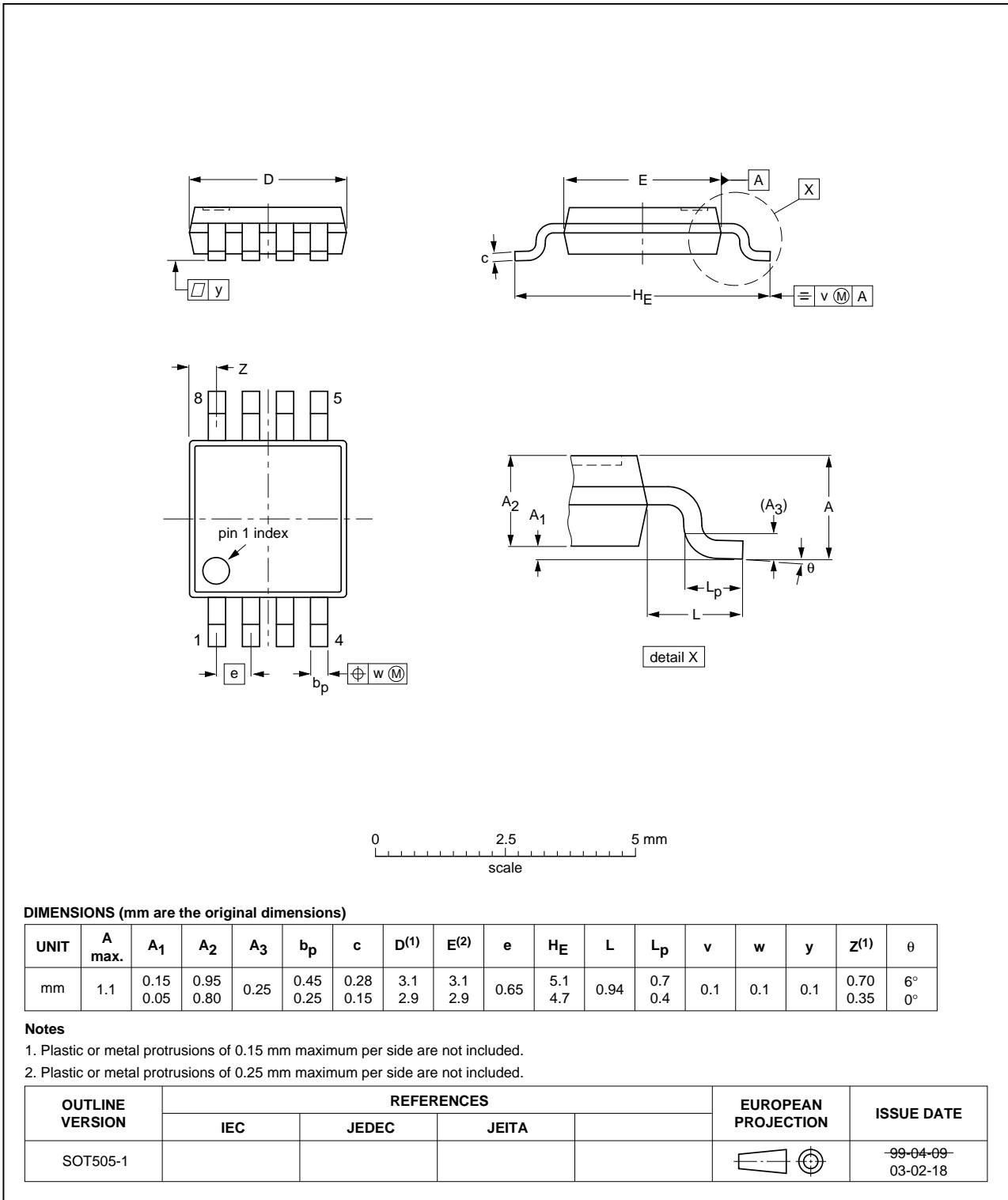

Fig 27. Package outline SOT505-1 (TSSOP8)

12. Soldering of SMD packages

This text provides a very brief insight into a complex technology. A more in-depth account of soldering ICs can be found in Application Note *AN10365 "Surface mount reflow soldering description"*.

12.1 Introduction to soldering

Soldering is one of the most common methods through which packages are attached to Printed Circuit Boards (PCBs), to form electrical circuits. The soldered joint provides both the mechanical and the electrical connection. There is no single soldering method that is ideal for all IC packages. Wave soldering is often preferred when through-hole and Surface Mount Devices (SMDs) are mixed on one printed wiring board; however, it is not suitable for fine pitch SMDs. Reflow soldering is ideal for the small pitches and high densities that come with increased miniaturization.

12.2 Wave and reflow soldering

Wave soldering is a joining technology in which the joints are made by solder coming from a standing wave of liquid solder. The wave soldering process is suitable for the following:

- Through-hole components
- Leaded or leadless SMDs, which are glued to the surface of the printed circuit board

Not all SMDs can be wave soldered. Packages with solder balls, and some leadless packages which have solder lands underneath the body, cannot be wave soldered. Also, leaded SMDs with leads having a pitch smaller than ~0.6 mm cannot be wave soldered, due to an increased probability of bridging.

The reflow soldering process involves applying solder paste to a board, followed by component placement and exposure to a temperature profile. Leaded packages, packages with solder balls, and leadless packages are all reflow solderable.

Key characteristics in both wave and reflow soldering are:

- Board specifications, including the board finish, solder masks and vias
- Package footprints, including solder thieves and orientation
- The moisture sensitivity level of the packages
- Package placement
- Inspection and repair
- Lead-free soldering versus SnPb soldering

12.3 Wave soldering

Key characteristics in wave soldering are:

- Process issues, such as application of adhesive and flux, clinching of leads, board transport, the solder wave parameters, and the time during which components are exposed to the wave
- Solder bath specifications, including temperature and impurities

12.4 Reflow soldering

Key characteristics in reflow soldering are:

- Lead-free versus SnPb soldering; note that a lead-free reflow process usually leads to higher minimum peak temperatures (see [Figure 28](#)) than a SnPb process, thus reducing the process window
- Solder paste printing issues including smearing, release, and adjusting the process window for a mix of large and small components on one board
- Reflow temperature profile; this profile includes preheat, reflow (in which the board is heated to the peak temperature) and cooling down. It is imperative that the peak temperature is high enough for the solder to make reliable solder joints (a solder paste characteristic). In addition, the peak temperature must be low enough that the packages and/or boards are not damaged. The peak temperature of the package depends on package thickness and volume and is classified in accordance with [Table 8](#) and [9](#)

Table 8. SnPb eutectic process (from J-STD-020D)

Package thickness (mm)	Package reflow temperature (°C)	
	Volume (mm ³)	
	< 350	≥ 350
< 2.5	235	220
≥ 2.5	220	220

Table 9. Lead-free process (from J-STD-020D)

Package thickness (mm)	Package reflow temperature (°C)		
	Volume (mm ³)		
	< 350	350 to 2000	> 2000
< 1.6	260	260	260
1.6 to 2.5	260	250	245
> 2.5	250	245	245

Moisture sensitivity precautions, as indicated on the packing, must be respected at all times.

Studies have shown that small packages reach higher temperatures during reflow soldering, see [Figure 28](#).

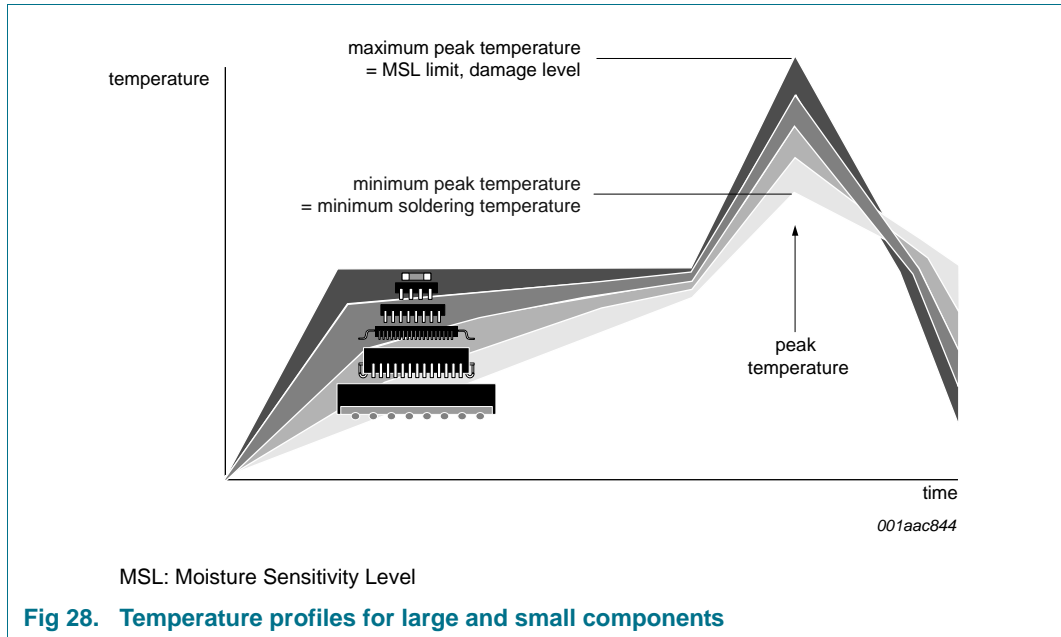

For further information on temperature profiles, refer to Application Note AN10365 “Surface mount reflow soldering description”.

13. Abbreviations

Table 10. Abbreviations

Acronym	Description
CDM	Charged-Device Model
ESD	ElectroStatic Discharge
HBM	Human Body Model
I ² C-bus	Inter-Integrated Circuit bus
I/O	Input/Output
IC	Integrated Circuit
PMBus	Power Management Bus
SMBus	System Management Bus
TTL	Transistor-Transistor Logic

14. Revision history

Table 11. Revision history

Document ID	Release date	Data sheet status	Change notice	Supersedes
PCA9600 v.6	20150925	Product data sheet	-	PCA9600 v.5
Modifications:	<ul style="list-style-type: none"> • HBM corrected from “4500 V” to “3500 V”. Original material was retested and is 3.5 kV • Updated Section 4 “Ordering information” • Table 4 “PCA9600 versus P82B96”: Deleted reference to DIP8 in P82B96 package column 			
PCA9600 v.5	20110505	Product data sheet	-	PCA9600 v.4
PCA9600 v.4	20091111	Product data sheet	-	PCA9600 v.3
PCA9600 v.3	20090903	Product data sheet	-	PCA9600 v.2
PCA9600 v.2	20080813	Product data sheet	-	PCA9600 v.1
PCA9600 v.1	20080602	Product data sheet	-	-

15. Legal information

15.1 Data sheet status

Document status ^{[1][2]}	Product status ^[3]	Definition
Objective [short] data sheet	Development	This document contains data from the objective specification for product development.
Preliminary [short] data sheet	Qualification	This document contains data from the preliminary specification.
Product [short] data sheet	Production	This document contains the product specification.

[1] Please consult the most recently issued document before initiating or completing a design.

[2] The term 'short data sheet' is explained in section "Definitions".

[3] The product status of device(s) described in this document may have changed since this document was published and may differ in case of multiple devices. The latest product status information is available on the Internet at URL <http://www.nxp.com>.

15.2 Definitions

Draft — The document is a draft version only. The content is still under internal review and subject to formal approval, which may result in modifications or additions. NXP Semiconductors does not give any representations or warranties as to the accuracy or completeness of information included herein and shall have no liability for the consequences of use of such information.

Short data sheet — A short data sheet is an extract from a full data sheet with the same product type number(s) and title. A short data sheet is intended for quick reference only and should not be relied upon to contain detailed and full information. For detailed and full information see the relevant full data sheet, which is available on request via the local NXP Semiconductors sales office. In case of any inconsistency or conflict with the short data sheet, the full data sheet shall prevail.

Product specification — The information and data provided in a Product data sheet shall define the specification of the product as agreed between NXP Semiconductors and its customer, unless NXP Semiconductors and customer have explicitly agreed otherwise in writing. In no event however, shall an agreement be valid in which the NXP Semiconductors product is deemed to offer functions and qualities beyond those described in the Product data sheet.

15.3 Disclaimers

Limited warranty and liability — Information in this document is believed to be accurate and reliable. However, NXP Semiconductors does not give any representations or warranties, expressed or implied, as to the accuracy or completeness of such information and shall have no liability for the consequences of use of such information. NXP Semiconductors takes no responsibility for the content in this document if provided by an information source outside of NXP Semiconductors.

In no event shall NXP Semiconductors be liable for any indirect, incidental, punitive, special or consequential damages (including - without limitation - lost profits, lost savings, business interruption, costs related to the removal or replacement of any products or rework charges) whether or not such damages are based on tort (including negligence), warranty, breach of contract or any other legal theory.

Notwithstanding any damages that customer might incur for any reason whatsoever, NXP Semiconductors' aggregate and cumulative liability towards customer for the products described herein shall be limited in accordance with the *Terms and conditions of commercial sale* of NXP Semiconductors.

Right to make changes — NXP Semiconductors reserves the right to make changes to information published in this document, including without limitation specifications and product descriptions, at any time and without notice. This document supersedes and replaces all information supplied prior to the publication hereof.

Suitability for use — NXP Semiconductors products are not designed, authorized or warranted to be suitable for use in life support, life-critical or safety-critical systems or equipment, nor in applications where failure or malfunction of an NXP Semiconductors product can reasonably be expected to result in personal injury, death or severe property or environmental damage. NXP Semiconductors and its suppliers accept no liability for inclusion and/or use of NXP Semiconductors products in such equipment or applications and therefore such inclusion and/or use is at the customer's own risk.

Applications — Applications that are described herein for any of these products are for illustrative purposes only. NXP Semiconductors makes no representation or warranty that such applications will be suitable for the specified use without further testing or modification.

Customers are responsible for the design and operation of their applications and products using NXP Semiconductors products, and NXP Semiconductors accepts no liability for any assistance with applications or customer product design. It is customer's sole responsibility to determine whether the NXP Semiconductors product is suitable and fit for the customer's applications and products planned, as well as for the planned application and use of customer's third party customer(s). Customers should provide appropriate design and operating safeguards to minimize the risks associated with their applications and products.

NXP Semiconductors does not accept any liability related to any default, damage, costs or problem which is based on any weakness or default in the customer's applications or products, or the application or use by customer's third party customer(s). Customer is responsible for doing all necessary testing for the customer's applications and products using NXP Semiconductors products in order to avoid a default of the applications and the products or of the application or use by customer's third party customer(s). NXP does not accept any liability in this respect.

Limiting values — Stress above one or more limiting values (as defined in the Absolute Maximum Ratings System of IEC 60134) will cause permanent damage to the device. Limiting values are stress ratings only and (proper) operation of the device at these or any other conditions above those given in the Recommended operating conditions section (if present) or the Characteristics sections of this document is not warranted. Constant or repeated exposure to limiting values will permanently and irreversibly affect the quality and reliability of the device.

Terms and conditions of commercial sale — NXP Semiconductors products are sold subject to the general terms and conditions of commercial sale, as published at <http://www.nxp.com/profile/terms>, unless otherwise agreed in a valid written individual agreement. In case an individual agreement is concluded only the terms and conditions of the respective agreement shall apply. NXP Semiconductors hereby expressly objects to applying the customer's general terms and conditions with regard to the purchase of NXP Semiconductors products by customer.

No offer to sell or license — Nothing in this document may be interpreted or construed as an offer to sell products that is open for acceptance or the grant, conveyance or implication of any license under any copyrights, patents or other industrial or intellectual property rights.

Export control — This document as well as the item(s) described herein may be subject to export control regulations. Export might require a prior authorization from competent authorities.

Non-automotive qualified products — Unless this data sheet expressly states that this specific NXP Semiconductors product is automotive qualified, the product is not suitable for automotive use. It is neither qualified nor tested in accordance with automotive testing or application requirements. NXP Semiconductors accepts no liability for inclusion and/or use of non-automotive qualified products in automotive equipment or applications.

In the event that customer uses the product for design-in and use in automotive applications to automotive specifications and standards, customer (a) shall use the product without NXP Semiconductors' warranty of the product for such automotive applications, use and specifications, and (b) whenever customer uses the product for automotive applications beyond NXP Semiconductors' specifications such use shall be solely at customer's

own risk, and (c) customer fully indemnifies NXP Semiconductors for any liability, damages or failed product claims resulting from customer design and use of the product for automotive applications beyond NXP Semiconductors' standard warranty and NXP Semiconductors' product specifications.

Translations — A non-English (translated) version of a document is for reference only. The English version shall prevail in case of any discrepancy between the translated and English versions.

15.4 Trademarks

Notice: All referenced brands, product names, service names and trademarks are the property of their respective owners.

I²C-bus — logo is a trademark of NXP B.V.

16. Contact information

For more information, please visit: <http://www.nxp.com>

For sales office addresses, please send an email to: salesaddresses@nxp.com

17. Contents

1	General description	1
2	Features and benefits	1
3	Applications	2
4	Ordering information	2
4.1	Ordering options	2
5	Block diagram	3
6	Pinning information	3
6.1	Pinning	3
6.2	Pin description	3
7	Functional description	4
8	Limiting values	7
9	Characteristics	8
10	Application information	13
10.1	Calculating system delays and bus clock frequency	15
10.2	Negative undershoot below absolute minimum value	19
10.2.1	Example with questions and answers	21
11	Package outline	24
12	Soldering of SMD packages	26
12.1	Introduction to soldering	26
12.2	Wave and reflow soldering	26
12.3	Wave soldering	26
12.4	Reflow soldering	27
13	Abbreviations	28
14	Revision history	29
15	Legal information	30
15.1	Data sheet status	30
15.2	Definitions	30
15.3	Disclaimers	30
15.4	Trademarks	31
16	Contact information	31
17	Contents	32

Please be aware that important notices concerning this document and the product(s) described herein, have been included in section 'Legal information'.

© NXP Semiconductors N.V. 2015.

All rights reserved.

For more information, please visit: <http://www.nxp.com>

For sales office addresses, please send an email to: salesaddresses@nxp.com

Date of release: 25 September 2015

Document identifier: PCA9600