



## Series 77 Shrink Boots Straight Lipless Boots How To Order

### Lipless Straight Shrink Boots



Table 1: Boot Size Selection Guide

Boot Size	Connector Diameter				Min. Cable Diameter	
	Inches		Millimeters			
	Min	Max	Min	Max	In.	mm.
00	.250	.325	6.35	8.26	.110	2.79
01	.300	.425	7.62	10.80	.150	3.81
02	.350	.600	8.89	15.24	.175	4.45
03	.450	.850	11.43	21.59	.225	5.72
04	.600	1.000	15.24	25.40	.275	6.99
05	.750	1.200	19.05	30.48	.300	7.62
06	.900	1.350	22.86	34.29	.375	9.53
07	1.250	1.650	31.75	41.91	.425	10.80
08	1.400	2.250	35.56	57.15	.625	15.88
09	1.800	2.500	45.70	63.50	.800	20.30
10	2.370	3.200	60.20	81.30	1.120	28.50

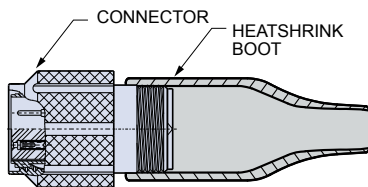

LIPLESS BOOT

### Lipless Straight Shrink Boots- Type I High Performance Elastomer

- **-75° C to +150° C**
- **Excellent resistance to fuels, oils, solvents and heat.**

Straight lipless boots for attachment directly to standard military circular connectors. Choose Type 1 high performance elastomer for extreme temperatures and excellent resistance to fuels and oils, Type 2 non-halogenated flame-retardant polyolefin for use where limited fire hazard is required, or choose Type 3 general purpose polyolefin for use where occasional exposure to heat and chemicals may occur.

Table 2: Material Selection Guide

Attribute	Type 1 High Performance Semi-Rigid Elastomer	Type 2 Zero Halogen Semi-Rigid Polyolefin	Type 3 General Purpose Flexible Polyolefin
Continuous Operating Temperature	-75° to +150°C	-30° to +125°C	-55° to +135°C
Resistance to Fuels, Oils, and Fluids	Excellent	Very Good	Good
Flammability	Self-Extinguishing <15 Sec.	Self-Extinguishing <15 Sec.	Self-Extinguishing <120 Sec.
Low Temperature Flexibility	-70°C	-30°C	-55°C
Low Toxicity, Zero Halogen	No	Yes	No

Table 3: Pre-Coated Boots Adhesive Information

Attribute	W2 Standard Hot Melt Adhesive	W1 High Temperature Hot Melt Adhesive	R High Performance Epoxy Adhesive
Boot Material Compatibility	Types 1, 2 and 3	Types 1, 2 and 3	Type 1
Continuous Operating Temp.	-40° to +80°C	-55° to +105°C	-75° to +150°C
Resistance to Fuels, Oils, and Fluids	Good	Good	Excellent
Low Toxicity, Zero Halogen	Yes	Yes	Yes

Semi-rigid high performance boots combine excellent resistance to fuels, oils and solvents with superior performance at extreme temperatures. Rated for 3000 hours continuous operation at +150° C, these boots fit standard circular connectors. Material meets the requirements of VG95343 Type 6, BSG 198-5-DE, EN62329-102 and SAE AS5258 Type H. These boots are recommended for demanding applications such as military vehicles and petrochemical exploration. Black color.

Boot Size	Part Number			
	No Adhesive Lining	Pre-Coated with W1 Hi-Temp Hot-Melt Adhesive	Pre-Coated with W2 Standard Hot-Melt Adhesive	Pre-Coated with R Epoxy Adhesive
00	770-005S100	770-005S100W1	770-005S100W2	770-005S100R
01	770-005S101	770-005S101W1	770-005S101W2	770-005S101R
02	770-005S102	770-005S102W1	770-005S102W2	770-005S102R
03	770-005S103	770-005S103W1	770-005S103W2	770-005S103R
04	770-005S104	770-005S104W1	770-005S104W2	770-005S104R
05	770-005S105	770-005S105W1	770-005S105W2	770-005S105R
06	770-005S106	770-005S106W1	770-005S106W2	770-005S106R
07	770-005S107	770-005S107W1	770-005S107W2	770-005S107R
08	770-005S108	770-005S108W1	770-005S108W2	770-005S108R
09	770-005S109	770-005S109W1	770-005S109W2	770-005S109R
10	770-005S110	770-005S110W1	770-005S110W2	770-005S110R

Dimensions in inches (millimeters) and are subject to change without notice.

© 2011 Glenair, Inc.

CAGE Code 06324

Printed in U.S.A.

GLENAIR, INC. • 1211 AIR WAY • GLENDALE, CA 91201-2497 • 818-247-6000 • FAX 818-500-9912

www.glenair.com

24

E-Mail: sales@glenair.com

Rev. 15-JULY-2010

## Series 77 Shrink Boots Straight Lipless Boots How To Order



### Lipless Straight Shrink Boots- Type 2 Zero Halogen, Semi-Rigid

- *Low Smoke, Zero Halogen*
- *Meets U.S. and E.U. toxicity requirements.*

Halogen-free polyolefin boots meet low smoke and toxicity requirements of shipboard, transit and aircraft systems. Oxygen index greater than 30%, smoke index less than 20, and toxicity index under 3 per 100 grams. Material meets requirements of NAVSEA 5617649, VG95343 Part 29, BSG 198-5-DF, EN62329-101 and SAE AS5258 Type G. Good resistance to oils, fuels and solvents. Available with high temperature hot melt adhesive lining, these boots provide strain relief and environmental protection to connector/cable transitions. Temperature rating -30° to +125° C. Black color.



Boot Size	Part Number		
	No Adhesive Lining	Pre-Coated with W1 Hi-Temp Hot-Melt Adhesive	Pre-Coated with W2 Standard Hot-Melt Adhesive
00	770-005S200	770-005S200W1	770-005S200W2
01	770-005S201	770-005S201W1	770-005S201W2
02	770-005S202	770-005S202W1	770-005S202W2
03	770-005S203	770-005S203W1	770-005S203W2
04	770-005S204	770-005S204W1	770-005S204W2
05	770-005S205	770-005S205W1	770-005S205W2
06	770-005S206	770-005S206W1	770-005S206W2
07	770-005S207	770-005S207W1	770-005S207W2
08	770-005S208	770-005S208W1	770-005S208W2
09	770-005S209	770-005S209W1	770-005S209W2
10	770-005S210	770-005S210W1	770-005S210W2

### Lipless Straight Shrink Boots- Type 3 Polyolefin, Flexible

- *General purpose harnessing*
- *Economical, flexible*
- *-55° C to +135° C*

Economical flexible polyolefin boots with no lip, for direct attachment to connectors. These self-extinguishing boots meet the requirements of SAE AS81765/1 Type II. Good resistance to oils and fuels. Available with optional hot melt adhesive lining, these boots provide strain relief and environmental protection to connector/cable transitions. Temperature rating -55° to +135° C. Black color.

Boot Size	Part Number		
	No Adhesive Lining	Pre-Coated with W2 Standard Hot-Melt Adhesive	Pre-Coated with W1 Hi-Temp Hot-Melt Adhesive
00	770-005S300	770-005S300W2	770-005S300W1
01	770-005S301	770-005S301W2	770-005S301W1
02	770-005S302	770-005S302W2	770-005S302W1
03	770-005S303	770-005S303W2	770-005S303W1
04	770-005S304	770-005S304W2	770-005S304W1
05	770-005S305	770-005S305W2	770-005S305W1
06	770-005S306	770-005S306W2	770-005S306W1
07	770-005S307	770-005S307W2	770-005S307W1
08	770-005S308	770-005S308W2	770-005S308W1
09	770-005S309	770-005S309W2	770-005S309W1
10	770-005S310	770-005S310W2	770-005S310W1

Dimensions in inches (millimeters) and are subject to change without notice.

## Lipless Straight Shrink Boots- Dimensions

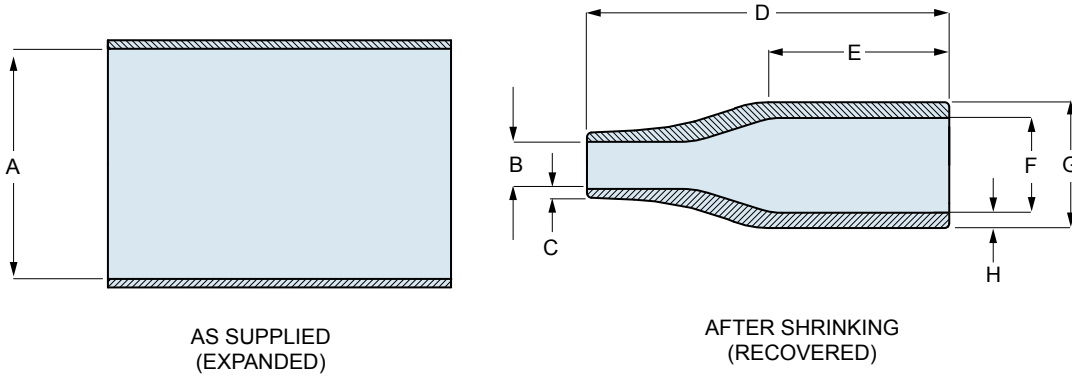

Boot Size	A Min.		B Max.		C $\pm 20\%$		D $\pm 10\%$		E Ref.		F Max.		G Ref.		H $\pm 30\%$	
	In.	mm.	In.	mm.	In.	mm.	In.	mm.	In.	mm.	In.	mm.	In.	mm.	In.	mm.
00	.354	9.0	.079	2.0	.028	0.7	.984	25.0	.551	14.0	.217	5.5	.295	7.5	.039	1.0
01	.472	12.0	.118	3.0	.028	0.7	.984	25.0	.551	14.0	.276	7.0	.362	9.2	.043	1.1
02	.669	17.0	.138	3.5	.028	0.7	1.181	30.0	.728	18.5	.276	7.0	.378	9.6	.051	1.3
03	.945	24.0	.197	5.0	.035	0.9	1.496	38.0	.748	19.0	.413	10.5	.520	13.2	.063	1.6
04	1.181	30.0	.236	6.0	.039	1.0	2.165	55.0	1.181	30.0	.551	14.0	.693	17.6	.071	1.8
05	1.260	32.0	.276	7.0	.047	1.2	2.638	67.0	1.299	33.0	.709	18.0	.850	21.6	.071	1.8
06	1.417	36.0	.335	8.5	.047	1.2	3.150	80.0	1.575	40.0	.866	22.0	.945	24.0	.079	2.0
07	1.693	43.0	.394	10.0	.051	1.3	3.898	99.0	2.165	55.0	1.102	28.0	1.276	32.4	.087	2.2
08	2.362	60.0	.591	15.0	.063	1.6	5.118	130.0	1.969	50.0	1.378	35.0	1.638	41.6	.130	3.3
09	2.600	66.0	.770	19.6	.080	2.0	6.350	161.3	3.550	90.2	1.720	43.7	2.020	51.3	.150	3.8
10	3.400	86.4	1.060	26.9	.085	2.2	8.370	212.6	4.450	113.0	2.250	57.2	2.570	65.3	.160	4.1

## Lipless Straight Boots- Part Marking, Raised Lettering

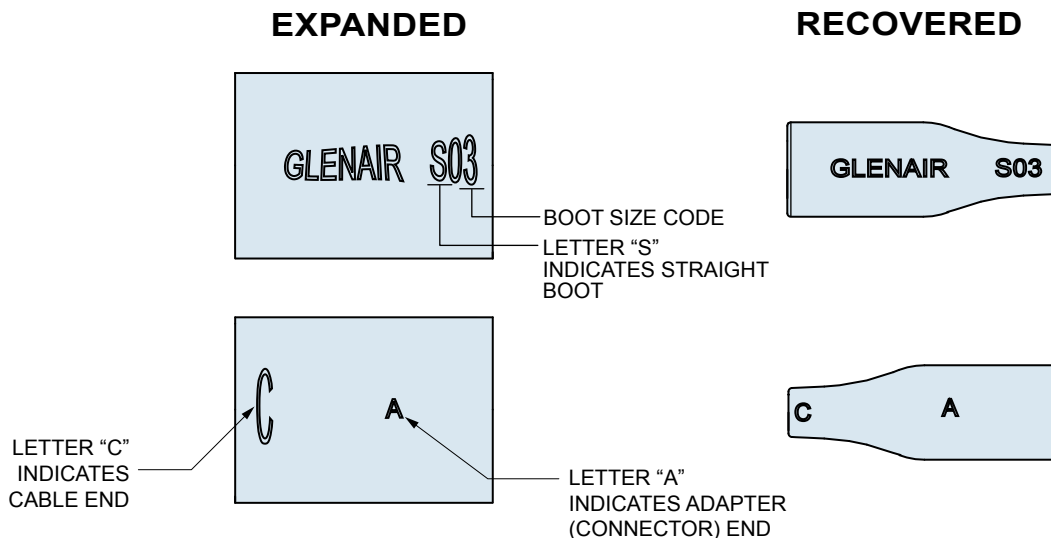

Dimensions in inches (millimeters) and are subject to change without notice.