

STRAIGHT CABLE JACK-CRIMP TYPE  
CABLE 2.6/50

SERIES: BNC 1 / 2

PEN 91-0104-124

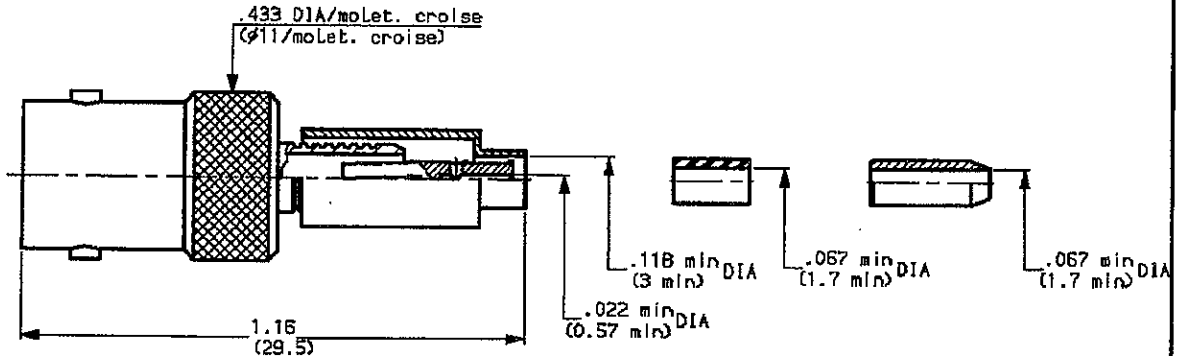

weight 0.35 oz ( 10 g)

CABLES :RG188

CHARACTERISTICS

NOMINAL IMPEDANCE	50 $\Omega$
FREQUENCY RANGE	0-4 GHz
TEMPERATURE RATING	-65/+165 °C
VSWR	AD Max
RF INSERTION LOSS	0.11 /F dB Maxi
VOLTAGE RATING	500 Vrms Maxi
DIELECTRIC WITHSTANDING VOLTAGE	1500 Vrms mini
INSULATION RESISTANCE	5000 Mo mini
HERMETIC SEAL	NA cc/s Atm.cm3/s
LEAKAGE (pressurized only)	NA psi MPa

STANDARDISATION MIL	STD348-301/BNC
CECC	22120/BNC
CEI	169-8/BNC

CABLE RETENTION 9 Lb mini  
40 N

CENTER CONTACT RETENTION

Axial force - mating end	6.075 Lb mini
Axial force - opposite end	6.075 Lb mini
Torque (Min)	NA Inch.oz cm. N

RECOMMENDED TORQUES

Mating	NA inch. Lb cm. N
Panel nut	NA inch. Lb cm. N
Clamp nut	NA inch. Lb cm. N

CONSTRUCTION

CONNECTOR PARTS	MATERIALS	FINISH
BODY	BRASS	NICKEL
OUTER CONTACT	BRASS	NICKEL
CENTER CONTACT	BERYLLIUM COPPER	GOLD
INSULATORS	PTFE + Polyamide	-
-	-	-
-	-	-
-	-	-
-	-	-

ISSUE	REVISION No	DESCRIPTION	BY	DATE
5737	95.06.015	braid clamp PTFE → Polyamide	Guarlu	17.09.97

Initiated on 31-JAN-91

The information given here is subject to change without notice. Design changes may be in order to improve the product.



Superseded on

STRAIGHT CABLE JACK-CRIMP TYPE  
TABLE 2.6/50

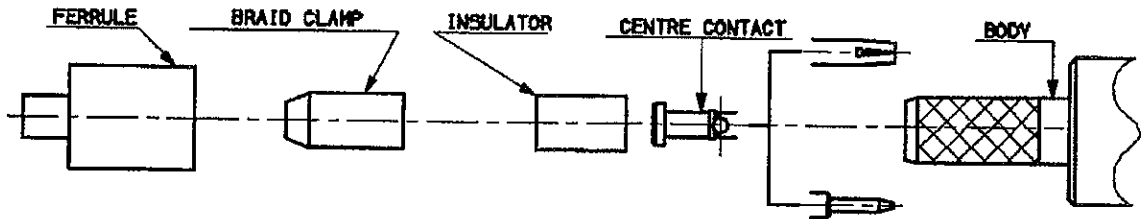

①

- 1-1 Slide onto the cable the ferrule
- 1-2 Strip the cable .
- 1-3 Fan the braid .

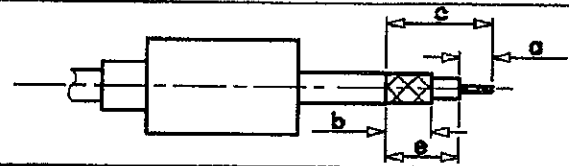

Stripping	a	b	c	d	e
Inch	.157	.394	.728	-	.571
mm	4	10	18.5	-	14.5

②

- 2-1 Slide the braid clamp and insulator between the dielectric and the braid .
- 2-2 Slide on the centre contact until it bottoms against cable dielectric .
- 2-3 Crimp centre contact , crimping tool R 282 223 000 (Hex. : .068 ) or crimping tool M22520/5-01 + dies M22520/5-11

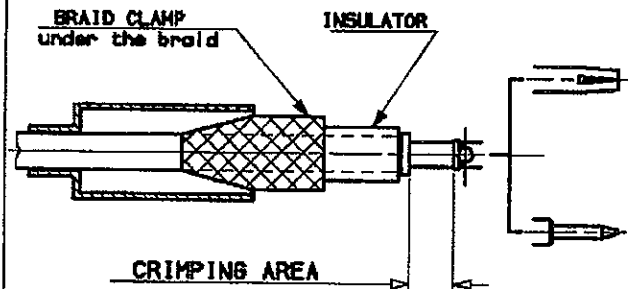

③

- 3-1 Slide cable into the body until bottoms against insulator .
- 3-2 Slide ferrule over the braid ( in direction F )

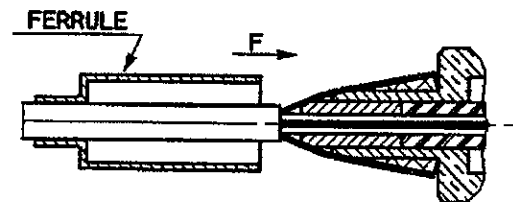

④

- 4-1 Crimp the ferrule with crimping tool R 282 223 000 (Hex. : .213 ) or Crimping tool M22520/5-01 + dies M22520/5-11
- 4-2 Cut the excess of braid .

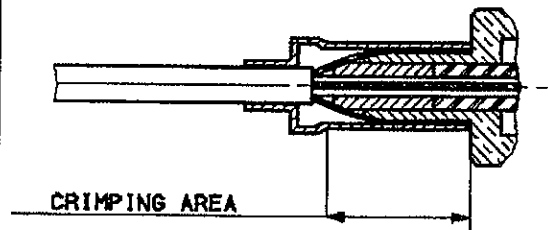

ISSUE	REVISION No	DESCRIPTION	BY	DATE

Initiated on 31-JAN-91

The information given here is subject to change without notice. Design changes may be in order to improve the product.



Approved on \_\_\_\_\_

# Mouser Electronics

Authorized Distributor

Click to View Pricing, Inventory, Delivery & Lifecycle Information:

Radial:

[R141217000](#) [R141217000W](#)