

THIS COPY IS PROVIDED ON A RESTRICTED BASIS AND IS NOT TO BE USED IN ANY WAY DETRIMENTAL TO THE INTERESTS OF PANDUIT CORP.

PANDUIT PART NUMBER	STUD SIZE	DIMENSIONS in.				
		A ±.03	W ±.01	C ±.02	M ±.03	H ±.01
PV2-10R	#10	1.96 (49.78)	.68 (17.27)	.58 (14.73)	1.62 (41.15)	.20 (5.08)
PV2-14R	1/4"	1.96 (49.78)	.68 (17.27)	.58 (14.73)	1.62 (41.15)	.27 (6.86)
PV2-56R	5/16"	1.96 (49.78)	.68 (17.27)	.58 (14.73)	1.62 (41.15)	.33 (8.38)
PV2-38R	3/8"	1.96 (49.78)	.68 (17.27)	.58 (14.73)	1.62 (41.15)	.39 (9.91)
PV2-12R	1/2"	2.05 (52.07)	.86 (21.84)	.58 (14.73)	1.62 (41.15)	.52 (13.21)

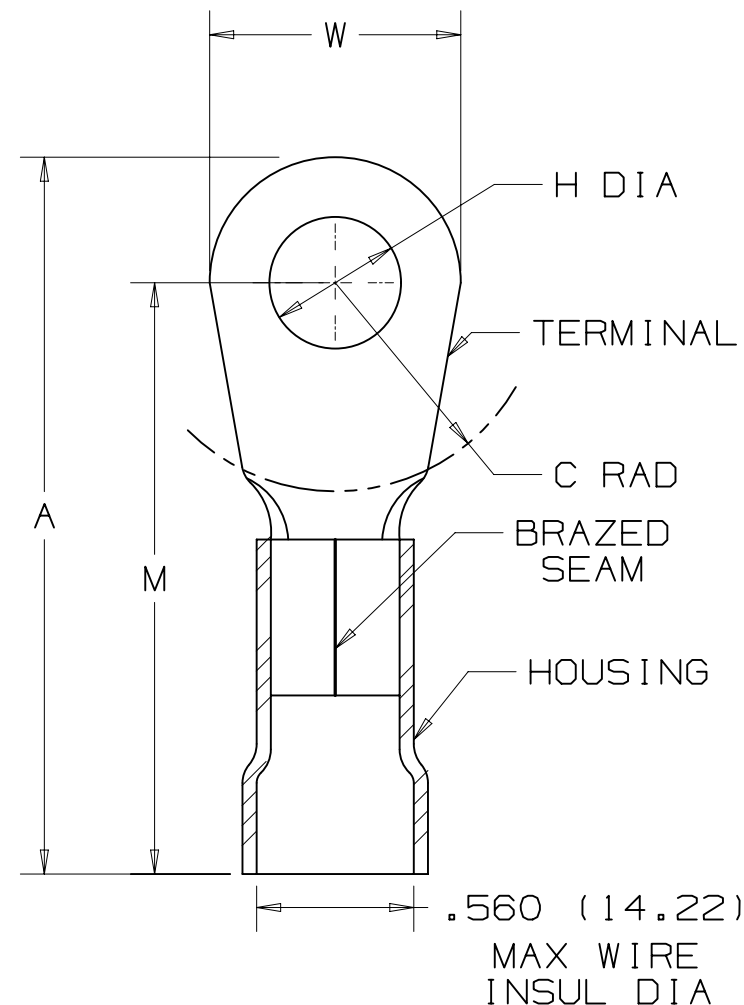

NOTES:

- UL LISTED FOR:
 - A. 600V MAX VOLTAGE RATING
 - B. 221° F (105° C) MAX TEMP RATING
 - C. #2 AWG STRANDED COPPER WIRE
- SEE www.panduit.com FOR PART NUMBER SUFFIX DESIGNATION FOR PACKAGE SIZE.
- MATERIAL:
 - A. STAMPING - .060" (1.52) THK COPPER, TIN PLATED
 - B. HOUSING - VINYL, RED
- DIMENSIONS IN BRACKETS ARE IN MILLIMETERS
- INSTALLATION TOOL: CT-720, CD-720PVB-2,
- WIRE STRIP LENGTH: 1/2" +1/32 [12.7 + 0.8 - 0



REV	DATE	BY	CHK	APR	DESCRIPTION	ECN
08	1/15	JHNU	TMR	RGB	REVISED LOGO TO cULus REVISED TITLE BLOCK	N41216BB-DC

TITLE		#2 BARREL VINYL INSULATED RING TONGUE .560 [14.22] MAX. WIRE INSUL. DIAMETER	
ITEM REVISION NAME		CUSTOMER DRAWING	
DATASET FILE NAME		N41216BB/08	
UNLESS OTHERWISE SPECIFIED, DIMENSIONAL TOLERANCES ARE: IN [mm]		MATERIAL:	
.X ± .XX ±		SEE NOTES	
.XXX ± ANGLES ±		DRAWING NUMBER:	
THIRD ANGLE PROJECTION		A41216	
DRAWN BY	DATE	CHK	SCALE
DAW			N/A
SHT 1 OF 1		A	

D10100DA/16