

V:1.0

Date: Oct.15.2009

# APPROVAL SHEET

Customer: Quartz-1  
Description: MCF 50.000MHz UM5\*2  
Part No.: FT50M30B  
Application: \_\_\_\_\_

<b>Approved by:</b>	<b>Checked by :</b>	<b>Issued by :</b> Ivy Wang
---------------------	---------------------	--------------------------------

Date: Oct.15.2007

FRONTER ELECTRONICS CO., LTD

Add.: Rm.1112~1117, Xinian Center 11/F, Shennan Rd. 6021,  
Shenzhen, China. 518040

TEL: 86-755 8345 8798

FAX: 86-755 8345 9818

E-mail: [ivy@chinafronter.com](mailto:ivy@chinafronter.com)

URL: <http://www.chinafronter.com>

## ■ SCOPE

This covers the characteristics of FT50M30B, which can be used in AV /OA Equipment, communication equipment and measuring instruments.

## ■ DIMENSIONS: See fig.1

## ■ ELECTRICAL CHARACTERISTICS

table 1

Item		Requirement	Note
Holder Type		UM-5	
Nominal frequency	<b>Fo</b>	50.0 MHz	@ 25°C
Operation Mode	<b>Mn</b>	Fundamental	
Operating temperature	<b>To</b>	-20 to 70 °C	
Store temperature	<b>ST</b>	-40 to 85 °C	
Pass band width	<b>BW</b>	±15KHz/3dB	
Stop band width		±50KHz/30dB	
Ripple		1.0 dB Max	
Insertion loss	<b>IL</b>	3.0dB Max	
Terminal impedance		560ohms//3.0pF	
Pole		4	

## ■ MEASUREMENT

item	REQUIREMENT
Test instrument	It shall be measured by DS7710A.
Test circuit	Fig 2
Measurement	Standard condition: (1) Temperature 25 ±3°C (2) Relative humidity 60± 10% R.H
Condition	The measurement shall be in the temperature range of 5°C to 35°C and relative humidity range of 45% to 85% when there are no faults

This standard is defined in accordance with IEC1178-1: 1993.OC6800000 and GB/T12273-1996.

## ■ PHYSICAL CHARACTERISTICS

Test Item	Condition of test	Performance Requirements
<b>Shock</b> (Destructive)	Crystal shall be tested after 3 times random drops from the height of 50 cm onto hard wooden board of thickness more than 30 mm.	No visible damage, and measured Values shall meet Table 1.
<b>Vibration</b> (Destructive)	Subject crystal to following vibration Frequency: 10-55Hz Amplitude: 0.75mm Cycle time: 1~2min(10-55-10Hz) Duration: 3 mutually perpendicular Planes in each 2 hours Direction: X, Y, Z	No visible damage, and measured Values shall meet Table 1.
<b>Terminal Strength</b> (Destructive)	<p>Pulling: body of crystal shall be fixed, and 1kg of tension weight shall be supplied gradually to axial direction of lead terminals for 30 seconds</p> <p>Bending: body of crystal shall be fixed, And 90°C bending at a distance of 2.5±0.5 mm from crystal main body shall be given being supplied 450g tension weight. after that, lead terminals shall be straightened gradually. Then, the same bending and straightening shall be supplied to the opposite direction in the same axial.</p>	The lead shall not be broken, Frequency value shall meet Table1 .
<b>Solder Heating</b> (Destructive)	Each lead terminals shall be dipped into the solder melted tank at 260±5°C for 5± 1 seconds to 2mm from the root of the crystal ,and at 240±10°C for 10 ± 1seconds by the same way.	No visible damage, and measured Values shall meet Table 1.
<b>Solder DIP.</b> (Destructive)	Dip the lead in liquid solder for 5 seconds, At 230±5°C and 2.0mm from the root , after this dipping , 95% min of dipped parts shall be covered with solder.	No visible damage, and measured Values shall meet Table 1.
<b>Leakage</b> (Non-destructive)	The crystal is to be soaked in the alcohol and enforced with the pressure of 25N/cm <sup>2</sup> for 5 minutes Next, the crystal shall be tested after being taken out and dried with a dryer.	The Ir between the wire and the shell must be more than 500M Ω .

■ ENVIRONMENT ENDURANCE:

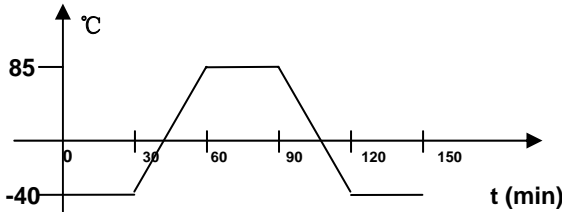
Test Item	Condition of test	Performance Requirements
<b>Heat Resistance</b> (non-destructive)	Subject crystal to $85\pm 5^{\circ}\text{C}$ for 16 hours, then place the crystal in natural condition for 1 hour.	No visible damage, measured Values shall meet Table1.
<b>Cold Resistance</b> (non-destructive)	Subject crystal to $-40\pm 5^{\circ}\text{C}$ for 2 hours, then, place the crystal in natural condition for 1 hour.	No visible damage, measured Values shall meet Table 1.
<b>Humidity</b>	Keep the crystal at $40\pm 2^{\circ}\text{C}$ and 90-95% R.H. for 96 hours. Then place it in natural condition for 1 hour.	The freq. meet $ \Delta f  \leq 5\text{ppm}$
<b>Temperature shock</b>	Temperature shaft from low to high, high to low For 24 hours. And then put the crystal in natural Condition for 1 hour. <div style="text-align: center; margin-top: 10px;">  </div>	No visible damage, measured Values shall meet Table 1..

■ DIMENSIONS:( UNIT: mm)

FIG.1

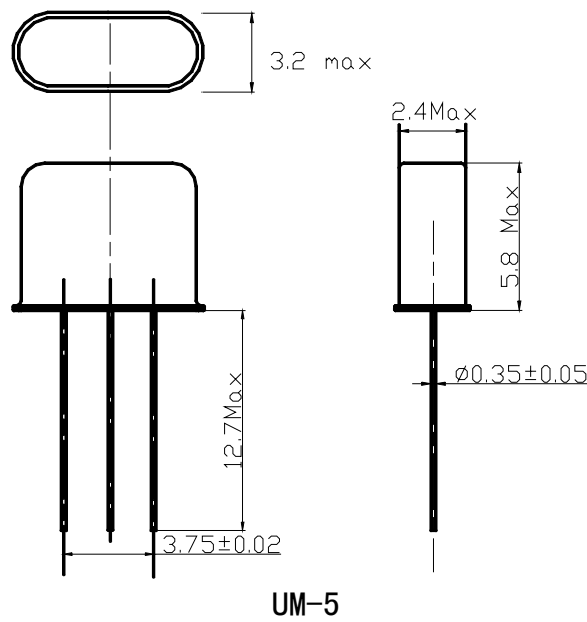

■ TEST CIRCUIT: (fund)

FIG.2

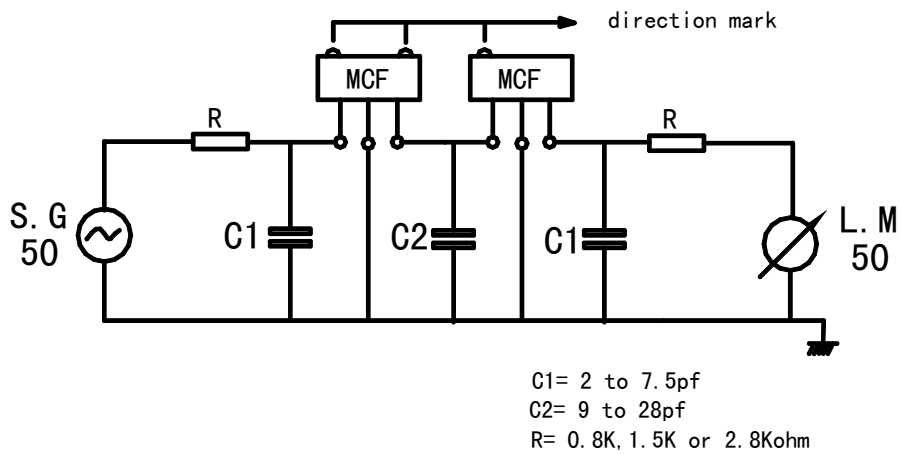

Test circuit (4 poles)

■ REVIEW OF SPECIFICATIONS

When something gets doubtful with these specifications, we shall jointly work to get an agreement.