

\* = Conical form tapering downward.  
 Untoleranced dimensions per GTA 13/5 DIN 1688

LID

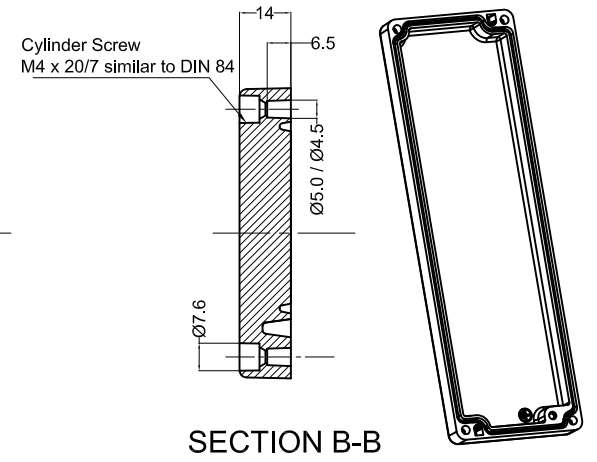
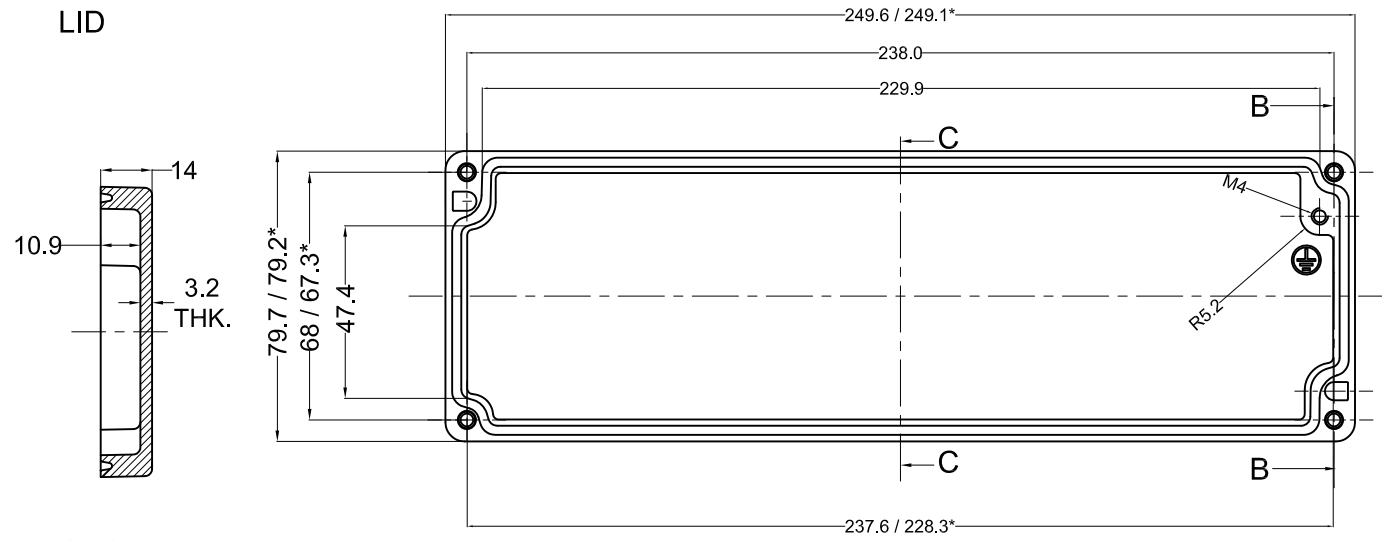

SECTION C-C

BASE

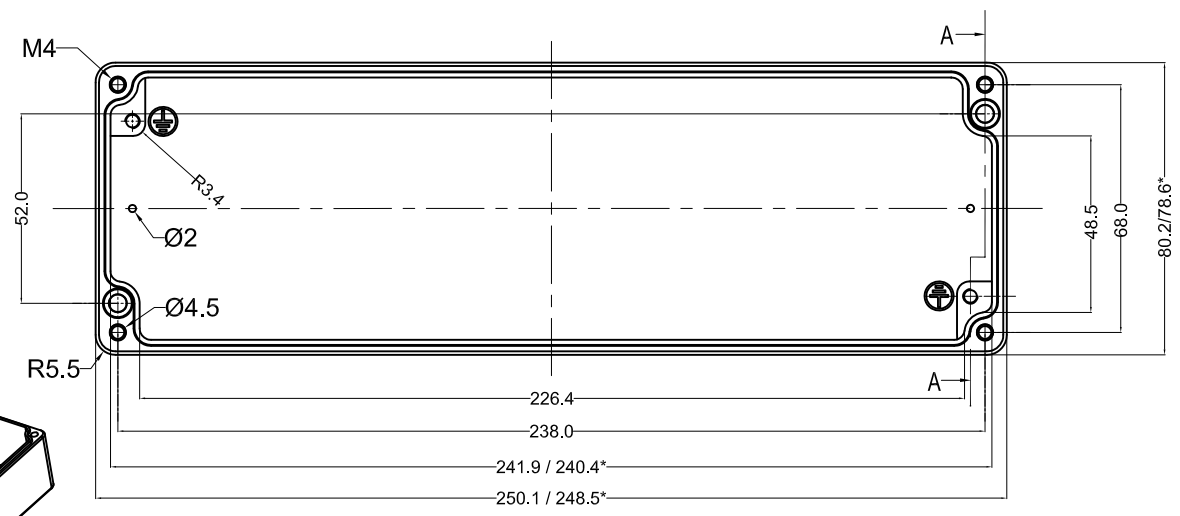

SECTION B-B

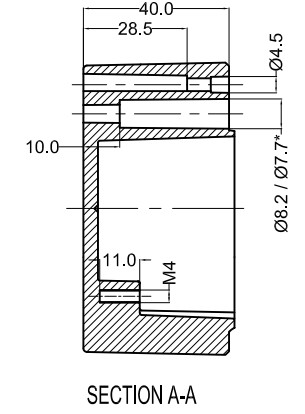

SECTION A-A

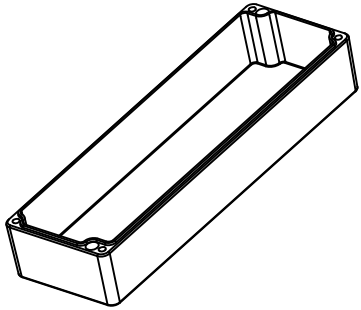

QUANTITY 1	MATERIAL :- <b>AlSi112 DIN230</b>	MACH.NAME -	DATE 09/06/12	SIGN MANOJ	NAME DRAWN
	WEIGHT: -	FINISH: NATURAL	DATE 09/06/12	SIGN PAVAN	NAME CHECKED
	TOLERANCE ±0.2	DIMENSIONS ±0.2	TITLE :- JUNCTION BOX 250 x 80 x 54		
±0.2 HOLES	ALL DIMENSION ARE IN MM		SCALE	PARTNO. 0	
±1.0° ANGLES	-		REV 0	DRG. NO. AJB-2508054	