

TCM Series

Conductive Polymer Solid Electrolytic Chip Multianode Capacitors



FEATURES

- Conductive Polymer Electrode, Multianode Design
- Benign Failure Mode Under Recommended Use Conditions
- Extremely Low ESR
- 3x Reflow 260°C Compatible
- 100% Surge Current Tested
- Volumetric Efficiency
- High Frequency Capacitance Retention



Elektra Award 2010



LEAD-FREE
LEAD-FREE COMPATIBLE
COMPONENT



SnPb termination option is not
RoHS compliant.

APPLICATIONS

- Telecommunication Routers
- Base Stations with High Power DC/DCs

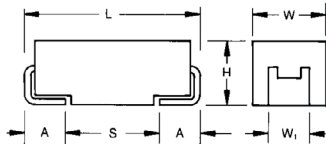

MARKING

E, V CASE

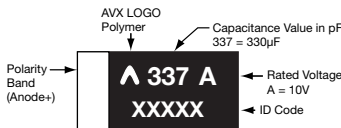

CASE DIMENSIONS:

millimeters (inches)

Code	EIA Code	EIA Metric	L±0.20 (0.008)	W±0.20 (0.008) -0.10 (0.004)	H±0.20 (0.008) -0.10 (0.004)	W ₁ ±0.20 (0.008)	A±0.30 (0.012) -0.20 (0.008)	S Min.
E	2917	7343-43	7.30 (0.287)	4.30 (0.169)	4.10 (0.162)	2.40 (0.094)	1.30 (0.051)	4.40 (0.173)
V	2924	7361-38	7.30 (0.287)	6.10 (0.240)	3.55 (0.140)	3.10 (0.122)	1.30 (0.051)	4.40 (0.173)

W₁ dimension applies to the termination width for A dimensional area only.

HOW TO ORDER

TCM	E	108	M	004	R	0010	E
Type	Case Size See table above	Capacitance Code pF code: 1st two digits represent significant figures, 3rd digit represents multiplier (number of zeros to follow)	Tolerance M = ±20%	Rated DC Voltage 002 = 2.5Vdc 004 = 4Vdc 006 = 6.3Vdc 010 = 10Vdc 016 = 16Vdc 020 = 20Vdc 025 = 25Vdc 035 = 35Vdc 050 = 50Vdc 100 = 100Vdc	Packaging R = Pure Tin 7" Reel S = Pure Tin 13" Reel H = Tin Lead 7" Reel K = Tin Lead 13" Reel	ESR in mΩ	Additional Character E = Black resin (it is possible to order PN without "E" as identical product)

TECHNICAL SPECIFICATIONS

Technical Data:	All technical data relate to an ambient temperature of +25°C
Capacitance Range:	10µF to 1000µF
Capacitance Tolerance:	±20%
Leakage Current DCL:	0.1CV
Temperature Range:	-55°C to +125°C
Termination Finish:	Sn Plating (standard) and SnPb Plating

NOTE: Conductive Polymer Capacitors are designed to operate within the limits of the environmental conditions specified for each series. If operated continuously at their maximum temperature and / or humidity limit, or beyond these limits, capacitors may exhibit a parametric shift in capacitance and increases in ESR. These changes may occur earlier if the specified environmental conditions are exceeded. Similarly, their normal operational time period will be significantly extended if their general duty cycle includes operation below maximum temperature within humidity controlled environments. Careful attention should be paid to maximum temperature with associated high humidity environments as well as voltage derating, ripple current and current surges. Please reference the AVX Conductive Polymer Capacitor Guidelines for more information or contact factory for application assistance.

TCM Series

Conductive Polymer Solid Electrolytic Chip Multianode Capacitors



CAPACITANCE AND RATED VOLTAGE RANGE (LETTER DENOTES CASE SIZE)

Capacitance		Rated Voltage DC (V _R) to 105°C									
µF	Code	2.5V (e)	4V (G)	6.3V (J)	10V (A)	16V (C)	20V (D)	25V (E)	35V (V)	50V (T)	100V (A)
10	106										V(50)
15	156									E(100)	
22	226								E(25)	E(75)	
33	336							E(60)	E(60)		
47	476							E(60)	E(45,60)		
68	686						E(25)	E(50)			
100	107					E(25)	E(25)				
150	157					E(25,40)					
220	227				E(25)	E(25,40)					
330	337			E(10,15)	E(10,15)	E(15, 25)					
470	477	E(10,12)	E(10,12)	E(7,10,12)	E(15, 25)						
680	687	E(10,12)	E(10,12)	E(12)							
1000	108	E(6,10,12)	E(6,8,10,12)								

Released ratings, (ESR ratings in mOhms in parentheses)

Note: Voltage ratings are minimum values. AVX reserves the right to supply higher voltage ratings in the same case size, to the same reliability standards.

RATINGS & PART NUMBER REFERENCE

AVX Part No.	Case Size	Capacitance (µF)	Rated Voltage (V)	Maximum Operating Temperature (°C)	DCL Max. (µA)	DF Max. (%)	ESR Max. @ 100kHz (mΩ)	100kHz RMS Current (mA)			MSL
								45°C	85°C	125°C	
2.5 Volt @ 105°C											
TCME477M002#0010E	E	470	2.5	125	117.5	10	10	6400	4500	1600	3
TCME477M002#0012E	E	470	2.5	125	117.5	10	12	5800	4100	1500	3
TCME687M002#0010E	E	680	2.5	125	170	10	10	6400	4500	1600	3
TCME687M002#0012E	E	680	2.5	125	170	10	12	5800	4100	1500	3
TCME108M002#0006E	E	1000	2.5	125	250	10	6	8300	5800	2100	3
TCME108M002#0010E	E	1000	2.5	125	250	10	10	6400	4500	1600	3
TCME108M002#0012E	E	1000	2.5	125	250	10	12	5800	4100	1500	3
4 Volt @ 105°C											
TCME477M004#0010E	E	470	4	125	188	8	10	6400	4500	1600	3
TCME477M004#0012E	E	470	4	125	188	8	12	5800	4100	1500	3
TCME687M004#0010E	E	680	4	125	272	8	10	6400	4500	1600	3
TCME687M004#0012E	E	680	4	125	272	8	12	5800	4100	1500	3
TCME108M004#0006E	E	1000	4	125	400	8	6	8300	5800	2100	3
TCME108M004#0008E	E	1000	4	125	400	8	8	7200	5000	1800	3
TCME108M004#0010E	E	1000	4	125	400	8	10	6400	4500	1600	3
TCME108M004#0012E	E	1000	4	125	400	8	12	5800	4100	1500	3
6.3 Volt @ 105°C											
TCME337M006#0010E	E	330	6.3	125	198	8	10	6400	4500	1600	3
TCME337M006#0015E	E	330	6.3	125	198	8	15	5200	3600	1300	3
TCME477M006#0007E	E	470	6.3	125	282	10	7	7700	5400	1900	3
TCME477M006#0010E	E	470	6.3	125	282	10	10	6400	4500	1600	3
TCME477M006#0012E	E	470	6.3	125	282	10	12	5800	4100	1500	3
TCME687M006#0012E	E	680	6.3	125	408	8	12	5800	4100	1500	3
10 Volt @ 105°C											
TCME227M010#0025E	E	220	10	125	220	8	25	4000	2800	1000	3
TCME337M010#0010E	E	330	10	125	330	8	10	6400	4500	1600	3
TCME337M010#0015E	E	330	10	125	330	8	15	5200	3600	1300	3
TCME477M010#0015E	E	470	10	125	470	10	15	5200	3600	1300	3
TCME477M010#0025E	E	470	10	125	470	10	25	4000	2800	1000	3
16 Volt @ 105°C											
TCME107M016#0025E	E	100	16	125	160	8	25	4000	2800	1000	3
TCME157M016#0025E	E	150	16	125	240	8	25	4000	2800	1000	3
TCME157M016#0040E	E	150	16	125	240	8	40	3200	2200	800	3
TCME227M016#0025E	E	220	16	125	352	8	25	4000	2800	1000	3
TCME227M016#0040E	E	220	16	125	352	8	40	3200	2200	800	3
TCME337M016#0015E	E	330	16	125	528	8	15	5200	3600	1300	3
TCME337M016#0025E	E	330	16	125	528	8	25	4000	2800	1000	3
20 Volt @ 105°C											
TCME686M020#0025E	E	68	20	125	136	8	25	4000	2800	1000	3
TCME107M020#0025E	E	100	20	125	200	8	25	4000	2800	1000	3



The Important Information/Disclaimer is incorporated in the catalog where these specifications came from or available online at www.avx.com/disclaimer/ by reference and should be reviewed in full before placing any order.

TCM Series

Conductive Polymer Solid Electrolytic Chip Multianode Capacitors



AVX Part No.	Case Size	Capacitance (μF)	Rated Voltage (V)	Maximum Operating Temperature (°C)	DCL Max. (μA)	DF Max. (%)	ESR Max. @ 100kHz (mΩ)	100kHz RMS Current (mA)			MSL
								45°C	85°C	125°C	
25 Volt @ 105°C											
TCME336M025#0060E	E	33	25	125	82.5	8	60	2600	1800	700	3
TCME476M025#0060E	E	47	25	125	117.5	8	60	2600	1800	700	3
TCME686M025#0050E	E	68	25	125	170	8	50	2900	2000	700	3
35 Volt @ 105°C											
TCME226M035#0025E	E	22	35	125	77	8	25	4000	2800	1000	3
TCME336M035#0060E	E	33	35	125	115.5	8	60	2600	1800	700	3
TCME476M035#0045E	E	47	35	125	164.5	8	45	3000	2100	800	3
TCME476M035#0060E	E	47	35	125	164.5	8	60	2600	1800	700	3
50 Volt @ 105°C											
TCME156M050#0100E	E	15	50	125	75	10	100	2000	1400	500	3
TCME226M050#0075E	E	22	50	125	110	10	75	2300	1600	600	3
100 Volt @ 105°C											
TCMV106M100R/S0050E	V	10	100	125	100	8	50	2900	2000	700	3

Moisture Sensitivity Level (MSL) is defined according to J-STD-020. All technical data relates to an ambient temperature of +25°C. Capacitance and DF are measured at 120Hz, 0.5RMS with DC bias of 2.2 volts. DCL is measured at rated voltage after 5 minutes. ESR allowed to move up to 1.25 times catalog limit post mounting. For typical weight and composition see page 276. **NOTE: AVX reserves the right to supply higher voltage ratings or tighter tolerance part in the same case size, to the same reliability standards.**

RECOMMENDED DERATING FACTOR

Voltage and temperature derating as percentage of Vr.

Rated voltage	Operating Temperature		
	≤85°C	105°C	125°C
≤10V	90%	90%	60%
≥16V	80%	80%	54%

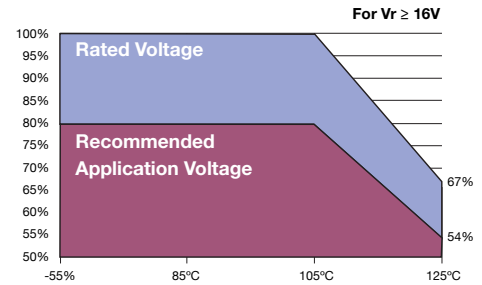
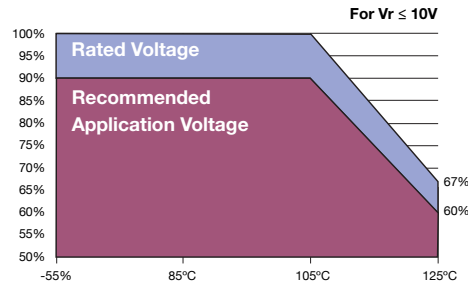

QUALIFICATION TABLE

TCM series (Temperature range -55°C to +125°C)											
TEST	Condition			Characteristics							
Endurance	Apply rated voltage (Ur) at 105°C and category voltage (Uc) at 125°C for 2000 hours through a circuit impedance of ≤0.1Ω/V. Stabilize at room temperature for 1-2 hours before measuring.			Visual examination	no visible damage						
				DCL	1.25 x initial limit						
				ΔC/C	within ±20% of initial value						
				DF	1.5 x initial limit						
				ESR	2 x initial limit						
Storage Life	Store at 125°C, no voltage applied, for 2000 hours. Stabilize at room temperature for 1-2 hours before measuring.			Visual examination	no visible damage						
				DCL	2 x initial limit						
				ΔC/C	within ±20% of initial value						
				DF	1.5 x initial limit						
				ESR	2 x initial limit						
Humidity	Store at 65°C and 95% relative humidity for 500 hours, with no applied voltage. Stabilize at room temperature and humidity for 1-2 hours before measuring.			Visual examination	no visible damage						
				DCL	3 x initial limit						
				ΔC/C	within +30/-20% of initial value						
				DF	1.5 x initial limit						
				ESR	2 x initial limit						
Temperature Stability	Step	Temperature°C	Duration(min)								
	1	+20	15								
	2	-55	15	DCL	IL*	n/a	IL*	10 x IL*	12.5 x IL*	IL*	
	3	+20	15	ΔC/C	n/a	+0/-20%	±10%	+20/-0%	+30/-0%	±10%	
	4	+85	15	DF	IL*	1.5 x IL*	IL*	1.5 x IL*	2 x IL*	IL*	
	5	+125	15								
Surge Voltage	Apply 1.3x category voltage (Uc) at 125°C for 1000 cycles of duration 6 min (30 sec charge, 5 min 30 sec discharge) through a charge/discharge resistance of 1000Ω			Visual examination	no visible damage						
				DCL	initial limit						
				ΔC/C	within +20/-30% of initial value						
				DF	1.25 x initial limit						

*Initial Limit

Initial measurement max. 1hr after the removal from dry pack or after pretreatment at 85°C for 24 hours.

TCM Series

Conductive Polymer Solid Electrolytic Chip Multianode Capacitors

SOLID ELECTROLYTIC CAPACITOR ROADMAP

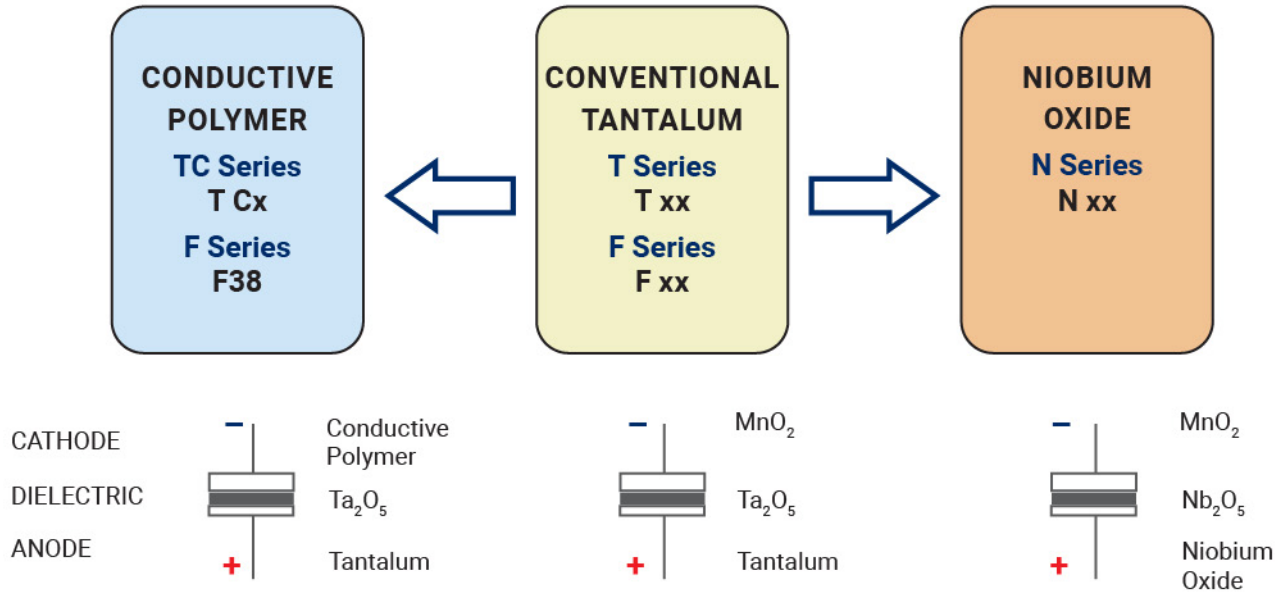

FIVE CAPACITOR CONSTRUCTION STYLES

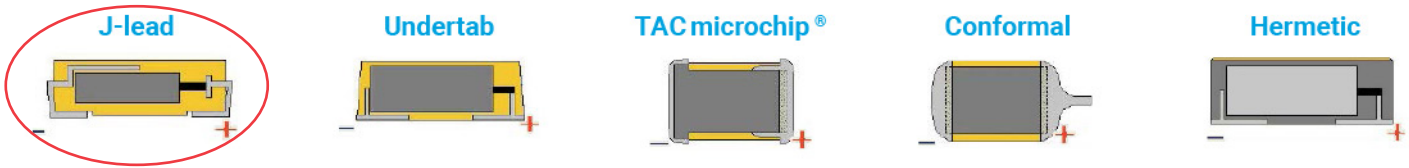

SERIES LINE UP : Conductive Polymer

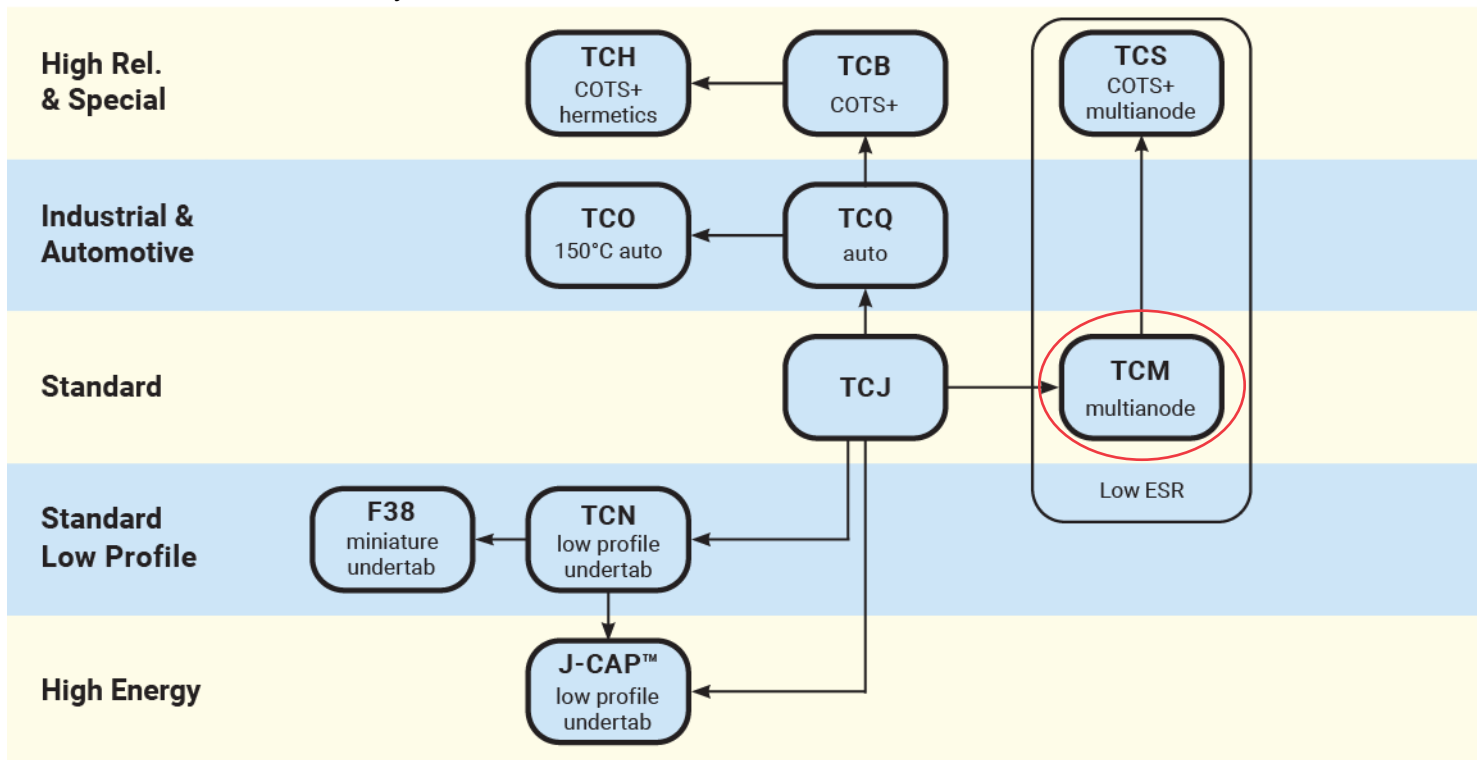

Mouser Electronics

Authorized Distributor

Click to View Pricing, Inventory, Delivery & Lifecycle Information:

AVX:

[TCME337M010R0010](#) [TCME108M004R0010](#) [TCME108M004R0012](#) [TCME226M035R0025](#) [TCME337M010R0015](#)
[TCME687M006R0012](#) [TCMV106M100R0050](#) [TCME108M004R0006](#) [TCME108M002R0010](#) [TCME477M006R0010](#)
[TCME477M006R0007](#) [TCME108M002R0006](#) [TCME337M006R0015](#) [TCME337M006R0010](#) [TCME687M004R0012](#)
[TCME227M016R0040E](#) [TCME336M025R0060E](#) [TCME336M035R0060E](#) [TCME476M025R0060E](#)
[TCME226M035R0025E](#) [TCME108M004R0006E](#) [TCME107M016R0025E](#) [TCME227M010R0025E](#)
[TCME477M004R0010E](#) [TCME686M020R0025E](#) [TCME687M002R0010E](#) [TCME687M004R0010E](#)
[TCME227M016R0025E](#) [TCME476M035R0045E](#) [TCME476M035R0060E](#) [TCME108M002R0012E](#)
[TCME477M002R0010E](#) [TCME477M002R0012E](#) [TCME477M004R0012E](#) [TCME477M006R0012E](#)
[TCME686M025R0050E](#) [TCME687M002R0012E](#) [TCME687M006R0012E](#)