

C-Series

Hydraulic-Magnetic Circuit Breaker

PRODUCT WEBPAGE

request sample, configure part

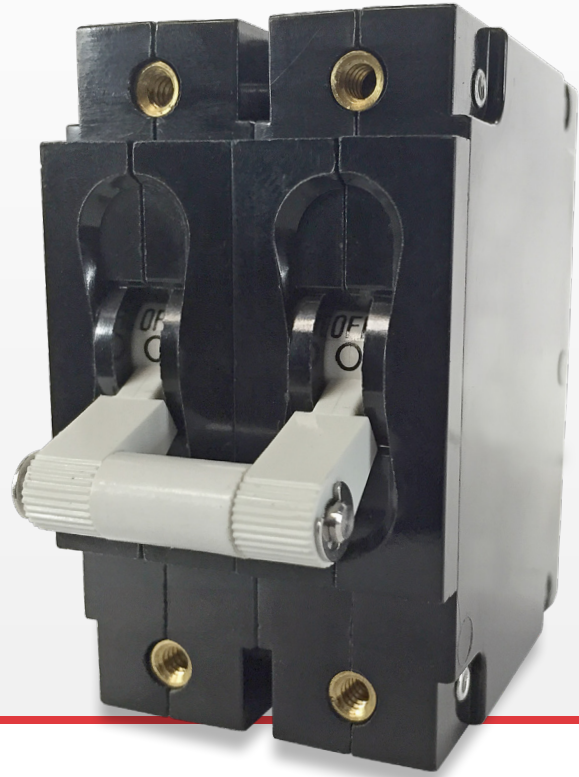

Compact Circuit Breaker with High Amperage and Voltage Capabilities

Compact yet robust, the C-Series hydraulic-magnetic circuit breaker is designed for high amperage and voltage applications. C-Series breakers are available as a one to six pole configuration and are rated up to 100 amps, 480VAC/80VDC or 240VAC/125VDC for UL 489 configurations. Parallel pole options offer ratings from 100–250 amps. The C-Series employs a unique arc chute design which allows for higher interrupting capacities of up to 10,000 amps.

1-6	250	480	125
Poles	Amps Max	VAC Max	VDC Max

Typical Applications

- Marine
- Datacom/Telecom
- Renewable Energy
- Generators & Welders
- Military

Tech Spec

Electrical

Maximum Voltage	AC, 480 WYE/277 VAC, 50/60 Hz (see Table A.) UL489: AC,240 VAC. (See Table D),50/60 Hz, 125 VDC
Current Ratings	Standard current coils: 0.100, 0.250, 0.500, 0.750, 1.00, 2.50, 5.00, 7.50, 10.0, 15.0, 25.0, 30.0, 35.0, 40.0, 50.0, 60.0, 70.0, 80.0, 90.0 and 100 amps. Other ratings available, see ordering scheme.
Standard Voltage Coils	DC - 6V, 12V; AC - 120V; other ratings available, see ordering scheme.
Auxiliary Switch Rating	SPDT; 10.1 amps-250VAC, DC Aux.Switch 1.0A, 65 VDC. 0.5A, 80VDC,1/4 HP, 125VAC,VDE & TVU1.0 125 VAC.
Insulation Resistance	Minimum of 100 Megohms at 500 VDC.
Dielectric Strength	UL, CSA: 1960 V 50/60 Hz for oneminute between all electrically isolated terminals. C-Series Circuit Breakers comply with the 8mm spacing and 3750V 50/60 Hz dielectric requirements from hazardous voltage to operator accessible surfaces, between adjacent poles and from main circuits to auxiliary circuits per Publications EN 60950 and VDE 0805.
Resistance, Impedance	Values from Line to Load Terminal -based on Series Trip Circuit Breaker.

RESISTANCE, IMPEDANCE VALUES from Line to Load Terminals (Values Based on Series Trip Circuit Breaker)

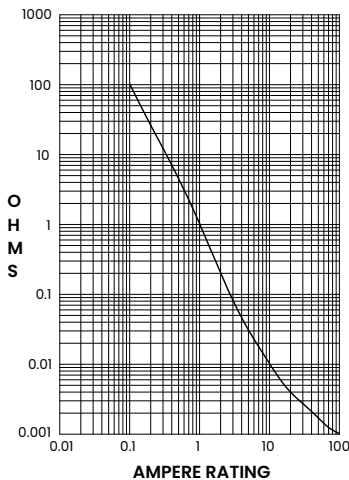

CURRENT (AMPS)	TOLERANCE (%)
0.10 - 5.0	15
5.1 - 20.0	25
20.1 - 50.0	35

Pulse Tolerance Curves

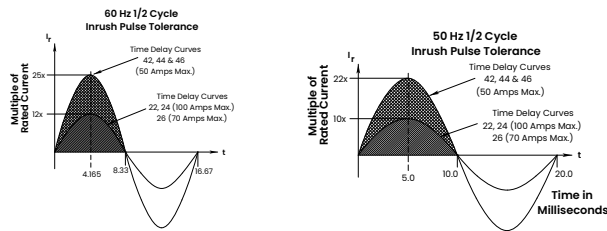

Mechanical

Endurance	10,000 ON-OFF operations @ 6 per minute; with rated current & voltage.
Trip Free	All circuit breakers will trip on overload, even when actuator is forcibly held in the ON position.
Trip Indication	The operating actuator moves positively to the OFF position when an overload causes the breaker to trip. With mid-trip, handle moves to the mid position on electrical trip of the circuit breaker. With mid trip handle with alarm switch, handle moves to the mid position and the alarm switch actuates when the circuit breaker is electrically tripped.
Number of Poles	1-6 poles ≤ 50A; 1-4 poles @ 51-70A; 1-2 poles 71-100A. UL489 Handle: 1 pole ≤ 100A, 2 pole ≤50A; Rocker: 1 pole ≤ 100A
Internal Circuit Config.	Series (with or without auxiliary switch, mid trip & mid trip with alarm switch) Shunt & Relay with current or voltage trip coils, Dual Coil, Switch Only (with or without aux. switch). UL489: Series (with or without auxiliary switch, mid-trip & midtrip with alarm switch).
Weight	Approx.112 grams/pole (3.95 oz).
Standard Colors	Housing: Black

Environmental

Designed and tested in accordance with requirements of specification MIL-PRF-55629 & MIL-STD-202 as follows:

Shock	Withstands 100Gs,6mssawtooth while carrying rated current perMethod 213, Test Condition "I". Instantaneous and ultrashort curves tested @ 90% of rated current.
Vibration	Withstands 0.060" excursion from 10-55 Hz & 10 Gs 55-500 Hz, @ rated current per Method 204C, Test Cond. A. Instantaneous & ultrashort curves tested @ 90% of rated current.
Moisture Resistance	Method 106D, i.e., ten 24-hour cycles @ +25°C to +65°C, 80-98% RH..
Salt Spray	Method 101, Condition A (90-95% RH @ 5% NaCl Solution, 96 hrs).
Thermal Shock	RH @ 5% NaCl Solution, 96 hrs). Thermal Shock Method 107D, Condition A (five cycles @ -55°C to +25°C to +85°C to +25°C).
Operating Temperature	-40° C to +85° C

Tech Specs

Tables

Table A: Lists UL Recognized & CSA Accepted configurations and performance capabilities as a component supplementary protector

Component Supplementary Protectors																			
Circuit Configuration	Voltage			Current Rating		Short Circuit Capacity (Amps)		Application Codes		Construction Notes									
	Max. Rating	Frequency	Phase	Full Load Amps	General Purpose Amps	UL / CSA		UL	CSA										
						With Backup Fuse	Without Backup Fuse												
Series	32	DC	---	0.02 - 100	---	---	5,000	TC1, OL1, U2	TC1, OL1, U2	---									
	48			110 - 150				TC1, 2, OL1, U1	TC1, 2, OL1, U1										
	65			0.02 - 70				71 - 100	TC1, 2, OL0, U1		TC1, 2, OL0, U1								
				-				---	TC1, 2, OL1, U1		TC1, 2, OL1, U1								
	80			0.02 - 70				---	7,500		TC1, 2, OL1, U1	TC1, 2, OL1, U1							
				---				71 - 100	10,000		TC1, 2, OL1, U1	TC1, 2, OL1, U1							
				0.02 - 70				---	5,000		TC1, 2, OL0, U1	TC1, 2, OL0, U1							
	125			50 / 60				1	0.02 - 50		---	---	---	TC1, 2, OL1, U1	TC1, 2, OL1, U1	Must have Agency "L"			
	125/250													TC1, 2, OL1, U1	TC1, 2, OL1, U1	Must have Agency "L"			
	250													TC1, 2, OL1, U1	TC1, 2, OL1, U1	Must have Agency "L". 250 volts requires 2 pole			
														---	---	3,000	TC1, OL1, U2	TC1, OL1, U2	Per pole rating
	150													DC	---	---	80 - 100 101 - 175	---	---
		---	---		5,000	TC1, 2, OL0, U3	---			Must have Agency "L"									
	125/250	50 / 60	1		0.02 - 100	---	---			---				3,500	TC1, OL1, U2	TC1, OL1, U2	---		
														3,000	TC1, 2, OL1, U1	TC1, 2, OL1, U1	2 or 3 poles breaking single phase		
														1,000	TC1, 2, OL1, U1	TC1, 2, OL1, U1	2 or 3 poles breaking single phase		
														5,000	TC1, 2, OL1, U2	TC1, 2, OL1, U2	2 or 3 poles breaking single phase. Agency "L"		
															3,500	TC1, 2, OL1, U2	TC1, 2, OL1, U2	Per pole rating	
														250	50 / 60	3	0.02 - 100	---	---
				---				---	3,000		TC1, 2, OL0, U2	TC1, 2, OL0, U2	---						
				480/277				50 / 60	3		0.02 - 70	---	---	5,000	5,000	TC1, 2, OL1, C1	TC1, 2, OL1, C1	3 poles breaking 3 phase	
															---	---	5,000	TC1, 2, OL0, U1	TC1, 2, OL0, U1
				480				50 / 60	1		0.02 - 30	---	---	5,000	---	---	---	---	
															---	---	---	---	---
Dual Coil				50 / 60				1	0.02 - 50		---	---	---	7,500	TC1, 2, OL1, U1	TC1, 2, OL1, U1	---		
	3,000	TC1, OL1, U2	TC1, OL1, U2		Per pole rating														
	3,500	TC1, OL1, U2	TC1, OL1, U2		2 or 3 poles breaking single phase														
	3,000	TC1, 2, OL1, U1	TC1, 2, OL1, U1		2 or 3 poles breaking single phase														
	3,500	TC1, OL1, U2	TC1, OL1, U2		---														
	277	50 / 60	3		0.02 - 50	---	---			5,000				---	---	---	Per pole rating		
														---	---	---	---	---	---
	480/277	50 / 60	3		0.02 - 30	---	---			5,000				---	---	---	3 poles breaking 3 phase		
														---	---	---	---	---	---
	Shunt	50 / 60	3		0.02 - 30	---	31 - 50			5,000				---	---	---	---		
														---	---	---	---	---	---
														---	---	---	---	---	---
---				---				---	---		---	---							
---				---				---	---		---	---							
---				---				---	---		---	---							
Relay	50 / 60	1	0.02 - 50	---	---	5,000	---	7,500	TC1, 2, OL1, U1	TC1, 2, OL1, U1	---								
							---	---	---	---	---	---							
							---	---	---	---	---	---							
							---	---	---	---	---	---							
							---	---	---	---	---	---							
							---	---	---	---	---	---							
Switch Only	50 / 60	1	0.02 - 100	---	---	---	---	---	---	---									
											65	71 - 100	---	---					
											80	---	---	---					
											125	---	---	---					
											125/250	---	---	---					
											250	---	---	---					
											277	---	---	---					
											480/277	---	---	---					

Notes:

- Requires branch circuit backup with a UL LISTED Type K5 or RK5 fuse rated 15A minimum and no more than 4 times full load amps not to exceed 125A for 50 Amp or less rating and not to exceed 175 for 51 through 100 Amp rating

Tech Specs

Tables

Table B: Lists UL Recognized and CSA Accepted configurations and performance capabilities as a Manual Motor Controller.

Manual Motor Controllers					
Circuit Configuration	Voltage			Current Rating	Horsepower Ratings
	Max. Rating	Frequency	Phase	Full Load Amps	Max. HP
Series, Shunt & Relay Switch Only	120 ¹	50 / 60	1	0.02 - 50	7 1/2
	250 ¹			0.02 - 20	3
	277 ¹				5
	480 ²				3

Notes:

- Requires branch circuit backup with a UL Listed Type K5 or RK5 fuse rated 15A Minimum and no more than 4 times full load amps not to exceed 125A for 50 Amp or less rating and not to exceed 175A for 51 through 100A rating. UL Recognized and CSA Certified at 480V refers to 3 and 4 pole versions used in a 3Ø, WYE connected circuit or a 2 pole version with 2 poles breaking 1Ø and backed up with a series fusing as stated in note 1.
- Shunt and Relay Trip - Voltage Coil Construction not current coils

Table C: Lists UL Recognized, CSA Accepted, VDE and TUV Certified configurations and performance capabilities as a Component Supplementary Protector.

Component Supplementary Protectors																			
Circuit Configuration	Voltage			Current Rating		Short Circuit Capacity (Amps)						Application Codes	Construction Notes						
	Max. Rating	Frequency	Phase	Full Load Amps	General Purpose Amps ¹	UL / CSA		VDE		TUV		UL / CSA							
						With Backup Fuse	Without Backup Fuse	(Inc) With Backup Fuse	(Inc) Without Backup Fuse	(Inc) With Backup Fuse	(Inc) Without Backup Fuse								
Series	80	DC	---	0.10 - 70	---	---	7,500	---	5,000	5,000	1,500	TC1,2,OL1,UI	---						
				71 - 100	71 - 100								10,000	---	---	5,000	TC1,2,OL0,UI	Agency F, H, J or R	
	125			50 / 60	1	1 - 50	---	5,000	3,000	1,500	3,000	1,500	TC1,2,OL1,UI	Agency J or R					
	0.10 - 50					0.10 - 70								0.10 - 100	0.10 - 90	---	---	5,000	5,000
	250	50 / 60	3	0.10 - 30	---	5,000 ²	---	3,000	1,500	3,000	1,500	TC1,2,OL1,C1	---						
				0.10 - 100									0.10 - 30	5,000	2,500	3,000	1,500	TC1,2,OL1,UI	Agency J or R
	415	50 / 60	3	0.10 - 30	---	5,000 ²	---	3,000	1,500	3,000	1,500	TC1,2,OL1,C1	Rocker						
				0.10 - 30									5,000	2,500	3,000	1,500	TC1,2,OL1,UI	Handle, Agency F, H, J or R	
	Dual Coil	80	DC	---	0.10 - 30	---	---	7,500	---	1,500	5,000	3,000	1,500	TC1,2,OL1,UI	---				
		250	50 / 60	1 & 3	0.10 - 30									5,000	3,000	1,500	3,000	1,500	TC1,2,OL1,UI
Shunt	80	DC	---	0.10 - 70	---	---	7,500	---	5,000	5,000	1,500	TC1,2,OL1,UI	---						
	250	50 / 60	1 & 3	0.10 - 70									5,000	3,000	1,500	3,000	1,500	TC1,2,OL1,UI	---
	415			3									0.10 - 30	5,000 ²	---	5,000	2,500	3,000	1,500

Notes:

- General Purpose ratings for UL/CSA only.
- Requires branch circuit backup with a UL LISTED Type K5 or RK5 fuse rated 15A minimum and no more than 4 times full load amps not to exceed 125A for 50 Amp or less rating and not to exceed 175 for 51 through 100 Amp rating.

Table D: Lists UL Listed (489), CSA Certified (C22.2 No. 5.1-M) configuration and performance capabilities as a Molded Case Circuit Breaker.

UL489 Listed Branch Circuit Breakers								
Circuit Configuration	Voltage			Current Rating	Interrupting Capacity (Amps)	Construction Notes		
	Max. Rating	Frequency	Phase	Full Load Amps	Without Backup Fuse			
Series	80	DC	---	0.10 - 100	50,000 ¹	Limited to 2 Poles Max from 71 - 100 Amps		
				101 - 150	10,000		2 Poles - Parallel Poles	
				151 - 250	10,000		3 Poles - Parallel Poles	
	125			50 / 60	1	0.10 - 100	5,000	1 - 3 Poles
	125 / 250					0.10 - 50	10,000	1 or 2 Poles (2 poles required for 250 Volts)
	120					51 - 70	5,000	1 - 3 Poles
	120 / 240	0.10 - 50	10,000 ¹			2 or 3 Poles (1 pole of a 3 pole unit is neutral)		
	240	50 / 60	1	0.10 - 30	5,000	1 Pole		
	277			0.10 - 20	10,000	2 Poles		
	Dual Coil			120	0.10 - 30	10,000	1-2 Poles	

Notes:

- Special catalog number required. Consult factory.

Tech Specs

Tables

Table E: Lists UL Recognized, CSA Accepted configurations and performance capabilities as Protectors, Supplementary for Marine Electrical and Fuel Systems (Guide PEQ22, File E75596). Ignition Protected per UL 1500. UL Classified Small Craft Electrical Devices, Marine in accordance with ISO 8846 (Guide UZMK, File MQ1515) as Marine Supplementary Protectors.

UL1500 (Marine Ignition Protection)								
Circuit Configuration	Voltage			Current Rating Full Load Amps	Interrupting Capacity (Amps) Without Backup Fuse	Application Codes		Construction Notes
	Max Rating	Frequency	Phase			UL	CSA	
Series	48	DC	---	0.02 - 100	5,000	TCI, 2, OLI, UI	TCI, 2, OLI, UI	---
	65			101 - 150				
	80			0.02 - 100	1,500	TCI, 2, OLO, UI	TCI, 2, OLO, UI	
	125	50 / 60	1	TCI, 2, OLI, UI		TCI, 2, OLI, UI		
	250			0.02 - 70	5,000	TCI, 2, OLI, UI	TCI, 2, OLI, UI	
				71 - 100		1,500	TCI, 2, OLI, UI	
				0.02 - 70	TCI, 2, OLI, UI		TCI, 2, OLI, UI	
	71 - 100	TCI, 2, OLI, UI	TCI, 2, OLI, UI					
								2 Poles Breaking Single Phase

Table F: Lists UL Listed configurations and performance capabilities as Circuit Breakers for use in Communications Equipment (Guide DITT, File E189195), under UL489A.

PARALLEL POLE CONSTRUCTION UL489A Listed for Communications Equipment				
Circuit Configuration	Voltage		Current Rating	Interrupting Capacity (Amps)
	Max. Rating	Frequency	General Purpose Amps	Without Backup Fuse
Series	80	DC	100 - 250	10,000

Agency Approvals

UL 1077	Component Recognition Program as Protectors Supplementary (Guide CCN/QVNU2, File E75596)
UL 508	Switches, Industrial Control (Guide CCN/NRNT2, File E148683)
UL 1500	Protectors, Supplementary for Marine Electrical & Fuel Systems (Guide PEQ22, File E75596) Ignition Protection
UL 489	Circuit Breakers, Molded Case, (Guide DIVQ, File E129899)
UL 489A	Communications Equipment (Guide CCN/DITT, File E189195)
CSA Accepted	Component Supplementary Protector under Class 3215 30, File 047848 0 000 CSA Standard C22.2 No. 235
CSA Certified	Circuit Breaker Model Case (Class 1432 01, File 093910), CSA Standard C22.2 No. 5.1 - M
TUV Certified	EN60934, under License No. R72040875
VDE Certified	EN60934, VDE 0642 under File No. 10537

Ordering Scheme Handle - UL 1077 Recognized

Sample Part Number

C A 3 - B 0 - 10 - 450 - 1 2 1 - C

Selection 1 2 3 4 5 6 7 8 9 10 11

1. SERIES

C

2. ACTUATOR ¹

- A Handle, one per pole
- B Handle, one per multipole unit
- S Mid-Trip Handle, one per pole
- T Mid-Trip Handle, one per pole & Alarm Switch

3. POLES ²

- | | | |
|-------|---------|--------|
| 1 One | 3 Three | 5 Five |
| 2 Two | 4 Four | 6 Six |

4. CIRCUIT ³

- | | |
|--------------------------------------|--|
| A ³ Switch Only (No Coil) | G ⁴ Relay Trip (voltage) |
| B Series Trip (Current) | H ^{4,5} Dual Coil with Shunt Trip (Gold Contacts) |
| C Series Trip (voltage) | K ^{4,5} Dual Coil with Relay Trip (Gold Contacts) |
| D ⁴ Shunt Trip (Current) | |
| E ⁴ Shunt Trip (voltage) | |
| F ⁴ Relay Trip (Current) | |

5. AUXILIARY / ALARM SWITCH ⁵

- | | |
|-------------------------------|-------------------------------|
| 0 without Aux Switch | 7 S.P.S.T., 0.139 Solder Lug. |
| 2 S.P.D.T., 0.110 Q.C. Term. | (Gold Contacts) |
| 3 S.P.D.T., 0.139 Solder Lug. | 8 S.P.S.T., 0.187 Q.C. Term. |
| 4 S.P.S.T., 0.093 Q.C. Term. | 9 S.P.D.T., 0.187 Q.C. Term. |

6. FREQUENCY & DELAY

- | | |
|------------------------------|---|
| 03 DC 50/60Hz, Switch Only | 31 DC, 50/60Hz Ultra Short |
| 10 DC Instantaneous | 32 DC, 50/60Hz Short |
| 11 DC Ultra Short | 34 DC, 50/60Hz Medium |
| 12 DC Short | 36 DC, 50/60Hz Long |
| 14 DC Medium | 42 ⁸ 50/60Hz Short, High-inrush |
| 16 DC Long | 44 ⁸ 50/60Hz Medium, High-inrush |
| 20 50/60Hz Instantaneous | 46 ⁸ 50/60Hz Long, High-inrush |
| 21 50/60Hz Ultra Short | 52 ⁸ DC, Short, High-inrush |
| 22 50/60Hz Short | 54 ⁸ DC, Medium, High-inrush |
| 24 50/60Hz Medium | 56 DC, Long, High-inrush |
| 26 50/60Hz Long | |
| 30 DC, 50/60Hz Instantaneous | |

Notes:

- 1 Actuator Code:
A: Handle tie pin spacer(s) and retainers provided assembled with multipole units. B: Handle location as viewed from front of breaker.
2 pole - left pole 3 pole - center pole 4 pole - two handles at center poles 5 pole - three handles at center poles 6 pole - four handles at center poles
S: Handle moves to mid-position only upon electrical trip of the breaker. Available with circuit codes B, C, D, E, F, G, H and K.
T: Handle moves to mid-position and alarm switch activates only upon electrical trip of the breaker. Available with circuit codes B & C.
- 2 Standard multipole units have all poles identical except when specifying auxiliary switch and/or mixed poles. 4 pole max with VDE. 5th pole available as Series Trip with Voltage Coil only.
- 3 Switch Only circuits, rated up to 50 amps and 6 poles, and only available with VDE Certification when tied to a protected pole (Circuit Code B, C, D or H.). For .02 to 30 amps, select Current Code 630. For 35 - 50 amps, select Current Code 650. For 55-70 amps, select Current Code 670. For 75-100 amps, select Current Code 810.
- 4 Circuit Codes D,E,F,G,H & K available with Terminal Codes 1,2,4 & 5 only. Circuit Codes D, F, H & K available up to 50 amps maximum Current Rating.
- 5 Consult factory for available Dual Coil options, as special catalog number is required. Dual Coil Voltage Coils with Shunt Trip Construction trip instantaneously on line voltage. Dual Coil Voltage Coils require 30VA minimum power to trip instantaneously and are rated for intermittent duty only.
- 6 Auxiliary Switch available with Series Trip & Switch Only circuits. On multi-pole breakers, one auxiliary switch is supplied, mounted in the extreme right pole.
- 7 Voltage coils not rated for continuous duty. Available only with delay codes 10 & 20.
- 8 Available with Circuit Codes B & D only, and up to 50 amps maximum.
- 9 Current Ratings 60 - 70 are available up to four poles maximum. Ratings 71 - 100 are available up to two poles maximum.
- 10 Terminal Code I available to 60 amps maximum.
- 11 Terminal Codes 2, 4, 5 and C available to 50 amps maximum.
- 12 Terminal Codes 3, 6 & 9 available to 100 amps maximum.
- 13 Terminal Code 7 available to 25 amps maximum.
- 14 Terminal Code A available to 100 amps maximum.
- 15 Terminal Codes 7, 9 & C are not VDE approved.
- 16 No marking available. Consult factory. VDE/TUV Approval requires dual (I-O, ON-OFF) or I-O markings on all handles.
- 17 Single pole only.
- 18 VDE/TUV: 30 amps max.; UL/CSA: 50 amps max.; Available in 2 - 4 poles only and limited to AC Delays. "General Purpose amps" not rated for "full load amps" or to be used in applications with a motor.

7. CURRENT RATING (AMPERES)

CODE	AMPERES	CODE	AMPERES	CODE	AMPERES	CODE	AMPERES
020	0.020	235	0.350	430	3.000	614	14.000
025	0.025	240	0.400	435	3.500	615	15.000
030	0.030	245	0.450	440	4.000	616	16.000
035	0.035	250	0.500	445	4.500	617	17.000
040	0.040	255	0.550	450	5.000	618	18.000
045	0.045	260	0.600	455	5.500	620	20.000
050	0.050	265	0.650	460	6.000	622	22.000
055	0.055	270	0.700	465	6.500	624	24.000
060	0.060	275	0.750	470	7.000	625	25.000
065	0.065	280	0.800	475	7.500	630	30.000
070	0.070	285	0.850	480	8.000	635	35.000
075	0.075	290	0.900	485	8.500	640	40.000
080	0.080	295	0.950	490	9.000	650	50.000
085	0.085	410	1.000	495	9.500	660 ⁹	60.000
090	0.090	512	1.250	610	10.000	670 ⁹	70.000
095	0.095	415	1.500	710	10.500	680 ⁹	80.000
210	0.100	517	1.750	611	11.000	685 ⁹	85.000
215	0.150	420	2.000	711	11.500	690 ⁹	90.000
220	0.200	522	2.250	612	12.000	695 ⁹	95.000
225	0.250	425	2.500	712	12.500	810 ⁹	100.000
230	0.300	527	2.750	613	13.000		

OR VOLTAGE COIL (NORMAL RATED VOLTAGE) ⁷

CODE	AMPERES	CODE	AMPERES	CODE	AMPERES	CODE	AMPERES
A06	6 DC	A32	32 DC	J12	12 AC	J65	65 AC
A12	12 DC	A48	48 DC	J18	18 AC	K20	120 AC
A18	18 DC	A65	65 DC	J24	24 AC	L40	240 AC
A24	24 DC	J06	6 AC	J48	48 AC		

8. TERMINAL ¹⁵

- | | |
|--------------------------------|---|
| 1 ¹⁰ Stud 10-32 | 6 ¹² Stud M6 |
| 2 ¹¹ Screw 10-32 | 7 ^{13,15} 0.250 Double Click Connect |
| 3 ¹² Stud 1/4-20 | 9 ¹⁵ 7/16" Clip Terminal |
| 4 ¹¹ Stud M5 x 0.8 | A ¹⁴ Plug-In Stud |
| 5 ¹¹ Screw M5 x 0.8 | C ^{11,15} 5/16" Clip Terminal |

9. ACTUATOR COLOR & LEGEND ¹⁶

Actuator Color	I-O	ON-OFF	Dual	Legend Color
White	A	B	1	Black
Black	C	D	2	White
Red	F	G	3	White
Green	H	J	4	White
Blue	K	L	5	White
Yellow	M	N	6	Black
Gray	P	Q	7	Black
Orange	R	S	8	Black
Black (short handle) ¹⁷	T	U	9	White

10. MOUNTING / BARRIERS

	MOUNTING STYLE	BARRIERS	VOLTAGE
1	Threaded Insert		
A	6-32 x 0.195 inches	no	< 300
C 18	6-32 X 0.195 inches	yes	< 300
2	6-32 X 0.195 inches	yes	≥ 300
B	ISO M3 x 5mm	no	< 300
D 18	ISO M3 x 5mm	yes	< 300
E 17	ISO M3 x 5mm	yes	≥ 300
	Front panel Snap-In, 1.00" [25.4mm] wide bezel with Handguard	no	< 300

11 AGENCY APPROVAL

- C UL Recognized, CSA Accepted
- D VDE Certified, UL Recognized, CSA Accepted
- E TUV Certified, UL Recognized, CSA Accepted
- H UL489 Construction: VDE Certified, UL Recognized, CSA Accepted
- I UL Recognized STD 1077, UL Recognized 1500 (ignition protected), CSA Accepted
- L UL489 Construction: UL Recognized, CSA Accepted
- R UL489 Construction: TUV Certified, UL Recognized, CSA Accepted

[Configure Complete Part Number >](#)

[Browse Standard Parts >](#)

Ordering Scheme

Handle - UL 489 & UL 489A Listed / Parallel Pole

Sample Part Number

C A 2 - P 0 - D4 - 820 - 3 2 1 - M T

Selection 1 2 3 4 5 6 7 8 9 10 11 12

1. SERIES

C

2. ACTUATOR 1

- A Handle, one per pole
- S Mid-Trip Handle, one per pole ¹
- T Mid-Trip, one per pole & Alarm Switch ¹

3. POLES 4

- 1 One
- 2 Two
- 3 Three

4. CIRCUIT

P Series Trip (parallel pole)

5 AUXILIARY/ALARM SWITCH 2

- 0 without Aux Switch
- 2 S.P.D.T., 0.110 Q.C. Term.
- 3 S.P.D.T., 0.139 Solder Lug
- 4 S.P.D.T., 0.110 Q.C. Term. (Gold Contacts)
- 5 S.P.S.T., N.O., 0.110 Q.C Term. (Gold Contacts)
- 6 S.P.S.T., 0.139 Solder Lug
- 7 S.P.S.T., 0.110 Q.C Term. (Gold Contacts)
- 8 S.P.S.T., 0.187 Q.C. Term.
- 9 S.P.D.T., 0.187 Q.C. Term.

6. FREQUENCY & DELAY

- D1 DC Ultra Short
- D2 DC Short
- D4 DC Medium
- D6 DC Long

7. CURRENT RATING (AMPERES)

CODE	AMPERES				
810	100.00	813	130.00	817	170.00
811	110.00	814	140.00	817	175.00
812	120.00	815	150.00	818	180.00
812	125.00	816	160.00	819	190.00
				820	200.00
				922	225.00
				825	250.00

8. TERMINAL 4

- 3 1/4-20 threaded Stud
- 6 M6 threaded Stud
- A Plug-in Stud ³

9 ACTUATOR COLOR & LEGEND

	Legend ON-OFF	Dual	Legend Color
White	B	1	Black
Black	D	2	White
Red	G	3	White
Green	J	4	White
Blue	L	5	White
Yellow	N	6	Black
Gray	Q	7	Black
Orange	S	8	Black

10. MOUNTING

- Threaded Insert
- 1 6-32 x 0.195 inches
- 2 ISO M3 x 5mm

11. MAXIMUM APPLICATION RATING

M 80 DC

12. AGENCY APPROVAL

- A Without Approval
- G UL489 Listed
- J UL489A Listed, TUV Certified
- K UL489A Listed, VDE Certified
- T UL489A Listed
- 7 UL489A Listed, TUV Certified

Notes:

- 1 Handle moves to Mid-Position only upon electrical trip of C/B when Actuator S is specified. When Actuator Code T is specified, handle moves to Mid Position and Alarm Switch actuates only upon electrical trip of C/B. Code T is only available with Circuit Code N.
- 2 Standard Handle colors are White, Black, Red & Yellow.
- 3 Breakers with Terminal Codes 3 & 6 are supplied with bus bars connecting the Line and Load Terminals. For Terminal Code A, Line and Load Terminals must be connected to a copper bus bar having a minimum cross-section of 0.078 square inches. Terminal Code A is not available on the single pole unit.
- 4 Ratings for 101 to 125 amps are available in 1-pole. Ratings from 110 to 200 amps are available in 2-pole. For ratings from 225-300 amps, specify 3-pole.
- 5 1 pole only available with terminal codes 3 and 6.
- 6 Agency codes K and 7 are not available with 1 pole. Agency code J is only available with 1 pole. Agency code G is only available in 2 and 3 pole. Circuit P, ratings 101-150 amps (2 pole) and ratings 151-250 amps (3 pole).

[Configure Complete Part Number >](#)

[Browse Standard Parts >](#)

Ordering Scheme Handle - UL 489 Listed

Sample Part Number **C A 3 - B 0 - 14 - 450 - 1 2 1 - K G**

Selection 1 2 3 4 5 6 7 8 9 10 11 12

1. SERIES

C

2. ACTUATOR ¹

- A Handle, one per pole
- B Handle, one per multipole unit
- S Mid-Trip Handle, one per pole
- T Mid-Trip Handle, one per pole & Alarm Switch

3. POLES ²

- 1 One
- 2 Two
- 3 Three

4. CIRCUIT

B Series Trip (Current)

5 AUXILIARY/ALARM SWITCH ²

- | | |
|------------------------------|--|
| 0 without Aux Switch | 8 S.P.S.T., 0.187 Q.C. Term. |
| 2 S.P.D.T., 0.110 Q.C. Term. | 9 S.P.D.T., 0.187 Q.C. Term. (Gold Contacts) |
| 3 S.P.D.T., 0.139 Solder Lug | |
| 4 S.P.D.T., 0.110 Q.C. Term. | |
| 6 S.P.S.T., 0.139 Solder Lug | |

6. FREQUENCY & DELAY

- | | |
|------------------------|---|
| 11 DC Ultra Short | 26 50/60Hz Long |
| 12 DC Short | 42 ⁴ 50/60Hz Short, High-inrush |
| 14 DC Medium | 44 ⁴ 50/60Hz Medium, High-inrush |
| 16 DC Long | 46 ⁴ 50/60Hz Long, High-inrush |
| 21 50/60Hz Ultra Short | 52 ⁴ DC Short, High-inrush |
| 22 50/60Hz Short | 54 ⁴ DC Medium, High-inrush |
| 24 50/60Hz Medium | 56 ⁴ DC Long, High-inrush |

Notes:

- 1 Actuator Code:
A: Handle tie pin spacer(s) and retainers provided assembled with multipole units.
B: Handle located, as viewed from front of breaker in left pole. 2 pole maximum.
S: Handle moves to mid-position only upon electrical trip of the breaker.
T: Handle moves to mid-position and alarm switch activates only upon electrical trip of the breaker.
- 2 Standard multipole units have all poles identical except when specifying auxiliary switch and/or mixed poles. 2 & 3 pole circuit breakers required for 120/240 VAC (Maximum application rating code C) applications, have all poles identical except when specifying auxiliary /alarm switch which is normally supplied in extreme right pole per figure B. Terminal barriers are required on all multipole breakers. Third pole is for 120/240 VAC applications requiring neutral disconnect. The 3rd pole has the same construction as poles 1 & 2.
- 3 On multi-pole breakers, one auxiliary switch is supplied, mounted in the extreme right pole. VDE approval on auxiliary switch codes 2, 3 & 4 only. Auxiliary / Alarm Switch with Independent Circuit ie: separate from breaker circuit, only available with circuit breakers rated 50 amp maximum at 80 VDC, 125 VDC, and 120 VAC. Auxiliary / Alarm Switch with Dependent Circuit ie: same as circuit breaker, is supplied from factory with common terminal of auxiliary / alarm switch connected to line terminal on 120/240 and 240 VAC ratings. Circuit breakers rated 120 VAC 50 amp maximum can be supplied with Auxiliary/Alarm switch common terminal connected to breaker line terminal. Consult factory for special catalog number.
- 4 Available up to 50 amps maximum.
- 5 Current ratings 71 - 100 with VDE approvals are available up to two poles maximum.
- 6 Terminal Codes 9 & C are not VDE approved.
- 7 Terminal Code 1 available to 60 amps maximum.
- 8 Terminal Codes 2, 4, 5 & C available to 50 amps maximum.
- 9 Terminal Codes 3, 6 & 9 available to 100 amps maximum.
- 10 Terminal Code A available to 100 amps maximum.
- 11 VDE and TUV approvals require Dual (I-O, ON-OFF) markings on all handles.
- 12 Barriers supplied on multi-pole units only.

7. CURRENT RATING (AMPERES) ⁴

CODE	AMPERES						
210	0.100	295	0.950	470	7.000	618	18.000
215	0.150	410	1.000	475	7.500	620	20.000
220	0.200	512	1.250	480	8.000	622	22.000
225	0.250	415	1.500	485	8.500	624	24.000
230	0.300	517	1.750	490	9.000	625	25.000
235	0.350	420	2.000	495	9.500	630	30.000
240	0.400	522	2.250	610	10.000	635	35.000
245	0.450	425	2.500	710	10.500	640	40.000
250	0.500	527	2.750	611	11.000	660	60.000
255	0.550	430	3.000	711	11.500	670	70.000
260	0.600	435	3.500	612	12.000	680	80.000
265	0.650	440	4.000	712	12.500	685	85.000
270	0.700	445	4.500	613	13.000	690	90.000
275	0.750	450	5.000	614	14.000	695	95.000
280	0.800	455	5.500	615	15.000	810	100.000
285	0.850	460	6.000	616	16.000		
290	0.900	465	6.500	617	17.000		

8. TERMINAL ⁶

- | | |
|-------------------------------|------------------------------------|
| 1 ⁷ Stud 10-32 | 6 ⁹ Stud M6 |
| 2 ⁸ Screw 10-32 | 9 ⁹ 7/16" Clip Terminal |
| 3 ⁹ Stud 1/4-20 | A ¹⁰ Plug-In Stud |
| 4 ⁸ Stud M5 x 0.8 | C ⁸ 5/16" Clip Terminal |
| 5 ⁸ Screw M5 x 0.8 | |

9 ACTUATOR COLOR & LEGEND

Actuator Color	ON-OFF	Dual	Legend Color
White	B	1	Black
Black	D	2	White
Red	G	3	White
Green	J	4	White
Blue	L	5	White
Yellow	N	6	Black
Gray	Q	7	Black
Orange	S	8	Black

10. MOUNTING

	MOUNTING STYLE	BARRIERS ¹²
1	Threaded Insert	yes
2	6-32 x 0.195 inches	yes
	ISO M3 x 5mm	yes

11. MAXIMUM APPLICATION RATING

- B 125 DC
- C 120/240 AC ²
- D 240 AC
- K 120 AC
- F 277 AC
- M 80 DC

12. AGENCY APPROVAL ¹¹

- A without approvals
- F UL489 Listed, CSA Certified & VDE Certified
- G UL489 Listed & CSA Certified
- J UL489 Listed, CSA Certified & TUV Certified

[Configure Complete Part Number >](#)

[Browse Standard Parts >](#)

Circuit & Terminal Diagrams Handle

inches [millimeters]

DESCRIPTION	CODE	DIMENSIONAL DETAIL	RATING (AMPS)			
			25	50	80	100
#10-32 STUD	1		█	█	█	█
M5 STUD	4		█	█	█	█
#1/4-20 STUD	3		█	█	█	█
M6 STUD	6		█	█	█	█
#1/4-20 STUD	3		█	█	█	█
M6 STUD	6		█	█	█	█
#10-32 SCREW	2		█	█	█	█
M-5 SCREW	5		█	█	█	█

DESCRIPTION	CODE	DIMENSIONAL DETAIL	RATING (AMPS)			
			25	50	80	100
.250 DOUBLE Q.C.	7		█	█	█	█
7/16" CLIP TERMINALS	9		█	█	█	█
PUSH-IN STUD	A		█	█	█	█

NOTES: TOLERANCE ON STUD LENGTHS IS $\pm .031$ [$\pm .79$] UNLESS OTHERWISE SPECIFIED.

AUXILIARY / ALARM SWITCH TERMINAL DETAIL³

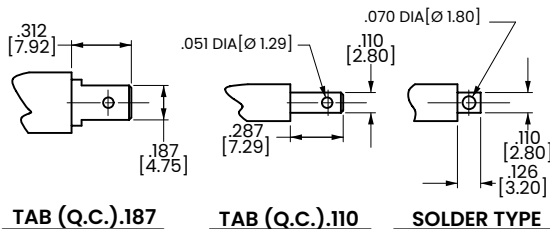

TAB (Q.C.) .187

TAB (Q.C.) .110

SOLDER TYPE

TIGHTENING TORQUE SPECIFICATIONS	
THREAD SIZE	TORQUE
#6-32 [M3] MOUNTING INSERTS	7-9 IN-LBS [0.8-1.0 NM]
#10-32 & M5 THD STUDS	15-20 IN-LBS [1.7-2.3 NM]
#10-32 THD SCREW	15-20 IN-LBS [1.7-2.3 NM]
#1/4-20 & M6 THD STUDS	30-35 IN-LBS [3.4-4.0 NM]

TERMINAL HARDWARE				
TERMINAL DESCRIPTION	CODE	AGENCY APPROVAL	AMPERE RATING	HARDWARE SUPPLIED
#10-32 STUD	1	ALL	.02-50	LOCK WASHER-FLAT WASHER-NUT
M5 STUD	4	ALL	.02-50	LOCK WASHER-FLAT WASHER-NUT
#1/4-20 STUD	3	ALL	.02-80	LOCK WASHER-FLAT WASHER-NUT
			81-100	LOCK WASHER-NUT-(2)FLAT WASHER-NUT
M6 STUD	6	ALL	.02-80	LOCK WASHER-FLAT WASHER-NUT
			81-100	LOCK WASHER-NUT-(2)FLAT WASHER-NUT
#10-32 SCREW	2 & 5	UL RECOGNIZED	.02-50	* SADDLE CLAMP-FLAT WASHER-SCREW
		UL-489 LISTED	.02-50	LOCK WASHER-FLAT WASHER-SCREW
		TUV & VDE CERTIFIED	.02-16	* SADDLE CLAMP-FLAT WASHER-SCREW
		TUV & VDE CERTIFIED	16.1-50	LOCK WASHER-FLAT WASHER-SCREW

* THE SADDLE CLAMP IS FOR DIRECT WIRE CONNECTION USE. DISCARD SADDLE CLAMP IF WIRE TERMINAL LUG IS USED

Notes:

- 1 Tolerance $\pm .020$ [.51] unless otherwise specified.
- 2 Available on Series Trip and Switch Only Circuits when called for on multi-pole units. Only one auxiliary switch is normally supplied, as viewed in multi-pole identification scheme.

Circuit & Terminal Diagrams Handle

inches [millimeters]

	CIRCUIT SCHEMATIC		CIRCUIT CODE	AUX. SWITCH CODE	CIRCUIT SCHEMATIC		CIRCUIT CODE	AUX. SWITCH CODE
	ANSI	IEC			ANSI	IEC		
	SWITCH ONLY (NO COIL)							
			A	0			B C	0
	SWITCH ONLY (NO COIL) WITH AUXILIARY SWITCH		A	2 3 4	SERIES TRIP WITH AUXILIARY/ALARM SWITCH		B C	2 3 4
	SHUNT TRIP		D E	0	DUAL COIL; SERIES TRIP CURRENT COIL, SHUNT TRIP VOLTAGE COIL		H	0
	RELAY TRIP		F G	0	DUAL COIL; SERIES TRIP CURRENT COIL, RELAY TRIP VOLTAGE COIL		K	0

HANDLE POSITION VS. AUX/ALARM SWITCH MODE					
CIRCUIT BREAKER MODE	STANDARD C/B		MID TRIP C/B		
	HANDLE POSITION	AUX. SWITCH MODE	HANDLE POSITION	STANDARD ALARM SWITCH MODE	REVERSE ALARM SWITCH MODE 4
OFF					
ON					
ELECTRICAL TRIP					

Notes:

- 1 Tolerance ± 0.020 [.51] unless otherwise specified.
- 2 Schematic shown represents current trip circuits.
- 3 Available only as special catalog number.

Dimensional Specs Handle

inches [millimeters]

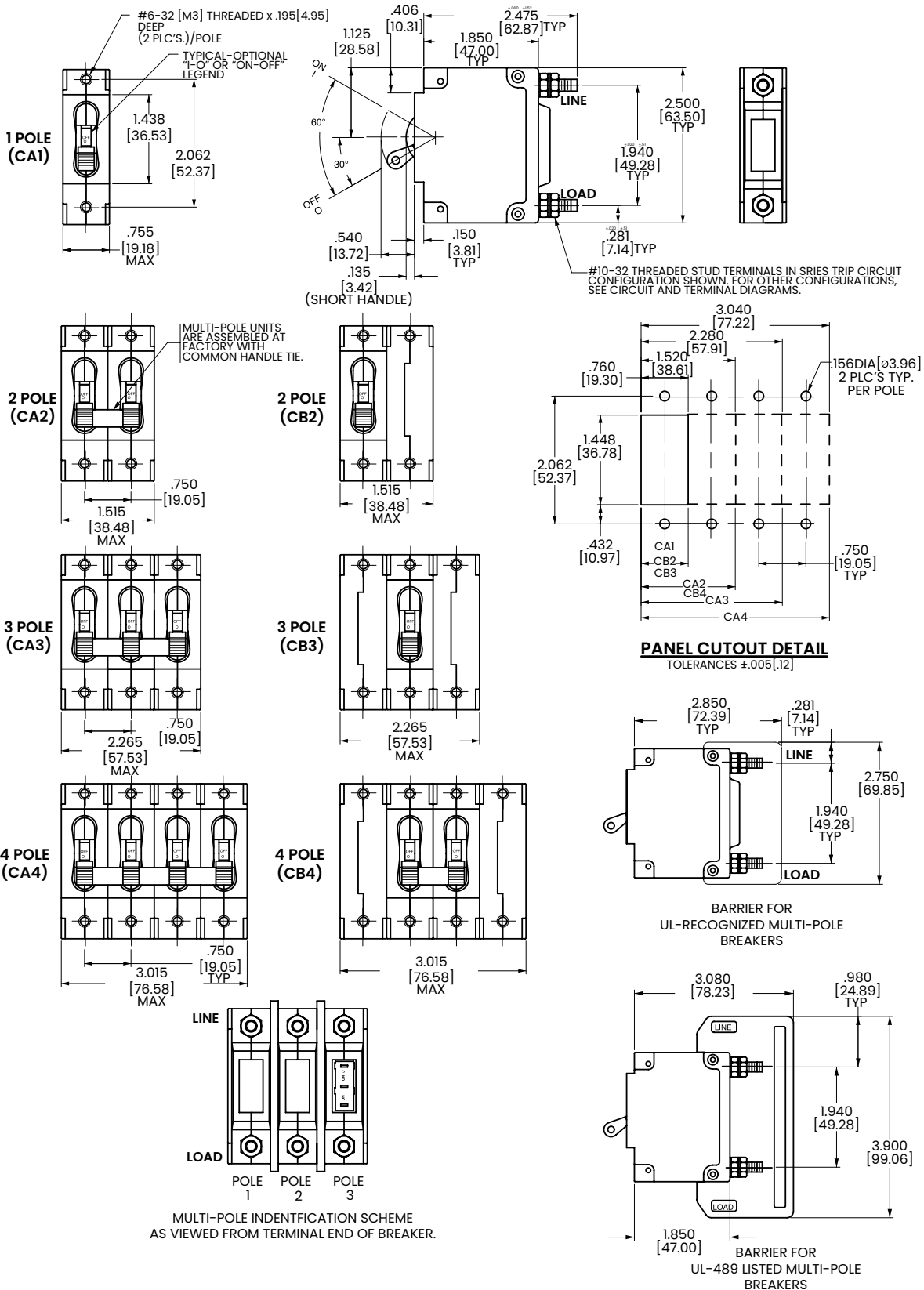

Notes:
1 Tolerance ±.020 [0.51] unless otherwise specified.

Dimensional Specs Handleguard

inches [millimeters]

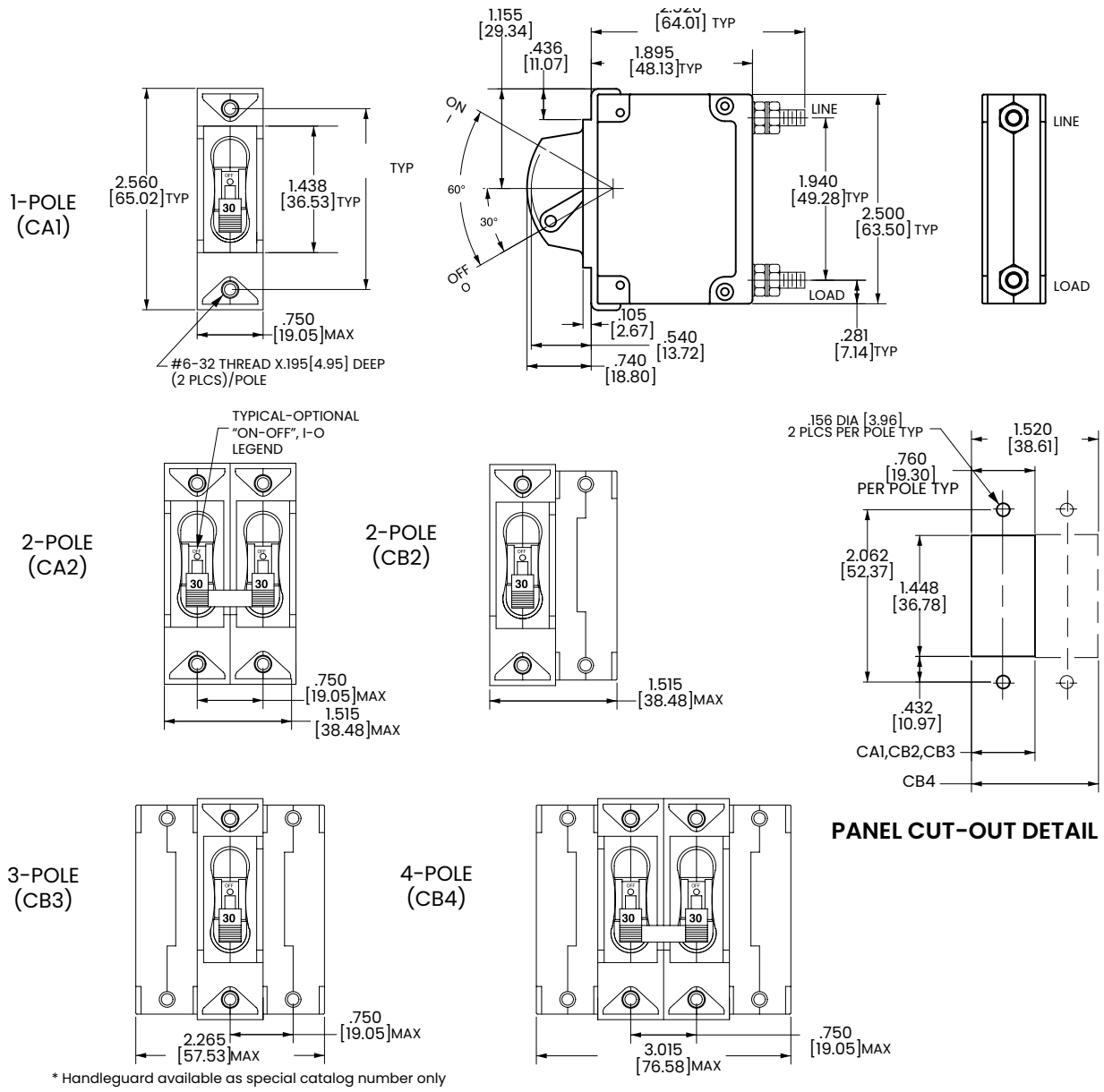

* Handleguard available as special catalog number only

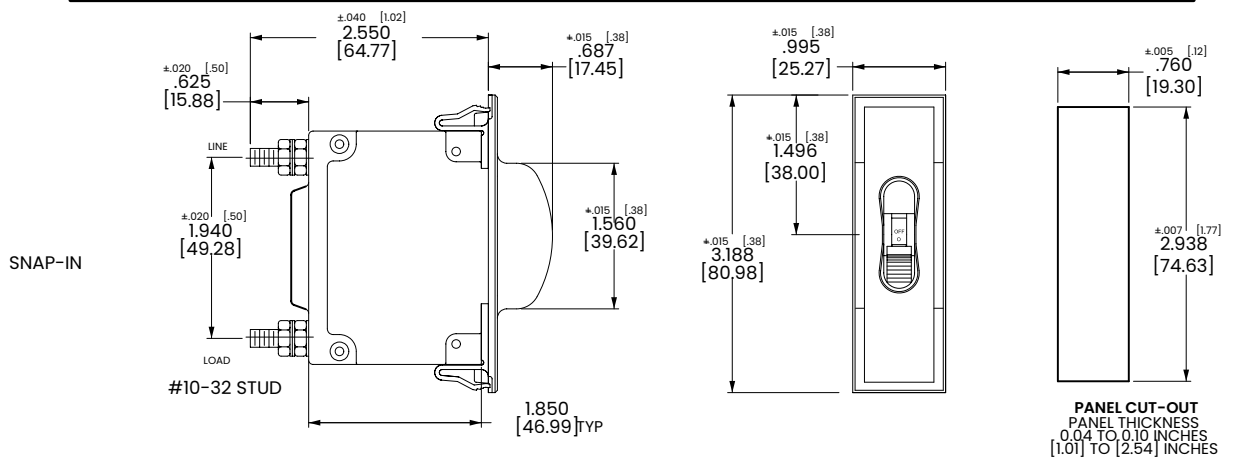

Notes:

1 Tolerance ±.020 [.51] unless otherwise specified.

Dimensional Specs Arc Chute Barrier

inches [millimeters]

1-POLE (CA1)
W/ ARC CHUTE BARRIER

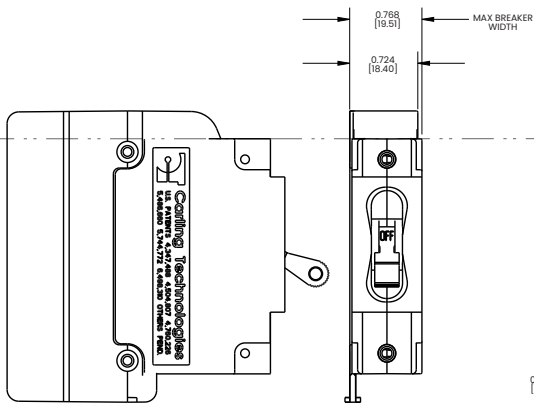

3-POLE (CA3)
W/ ARC CHUTE BARRIER

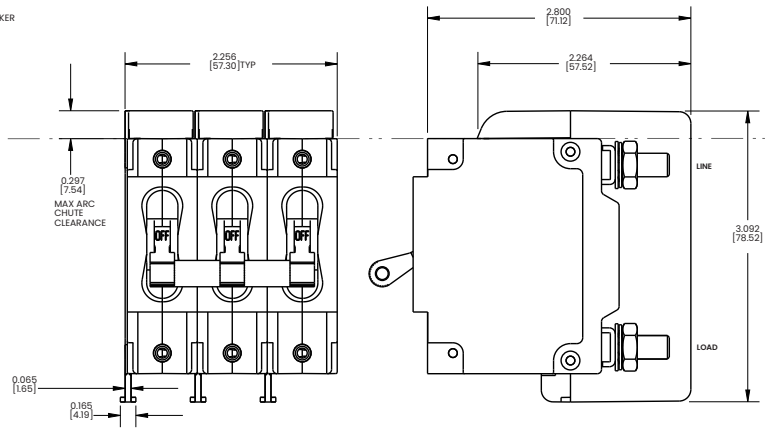

INDICATE "ON"

1-POLE (CC1, CD)
W/ ARC CHUTE (NO BARRIER)

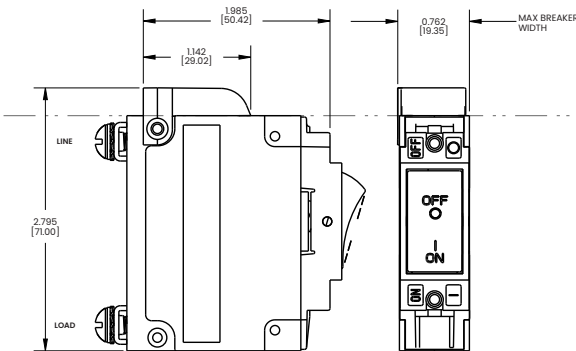

3-POLE (CC3, CD3)
W/ ARC CHUTE BARRIER

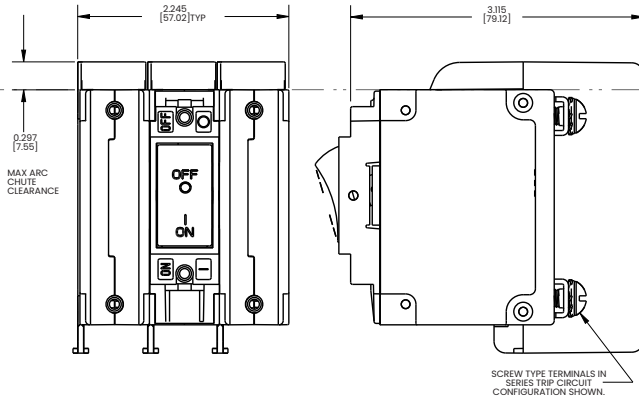

INDICATE "OFF" / SINGLE COLOR

1-POLE (CF1, CG1, C11, C21)
W/ ARC CHUTE (NO BARRIER)

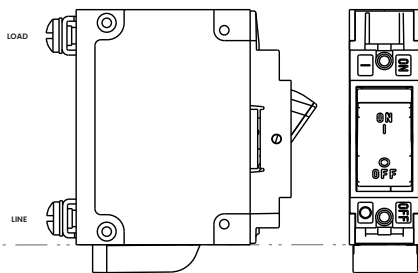

3-POLE (CF3, CG3, C13, C23)
W/ ARC CHUTE BARRIER

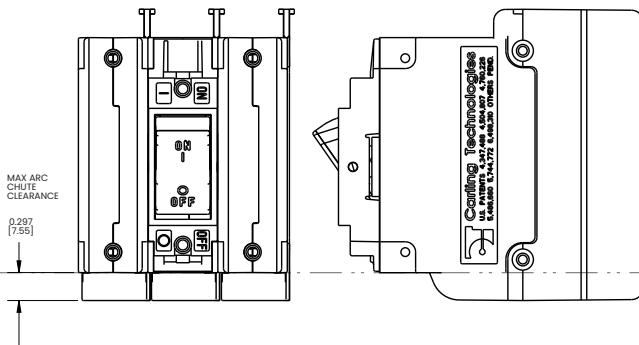

Notes:

- 1 Only 1-pole and 3-pole configurations shown. Arc chute (without barrier) and arc chute barrier also available for 2-pole construction.
- 2 Dimensions apply to all variations shown.
- 3 Notice that line and load terminal orientation for indicate on and indicate off rocker circuit breakers are opposite.
- 4 Screw type terminals shown for Rocker style (CF1, C11, etc) circuit breakers. For other terminal configurations see circuit and terminal diagrams.
- 5 Tolerance $\pm .020$ unless otherwise specified.
- 6 Must be ordered under a special catalog number.

Dimensional Specs Parallel Pole

inches [millimeters]

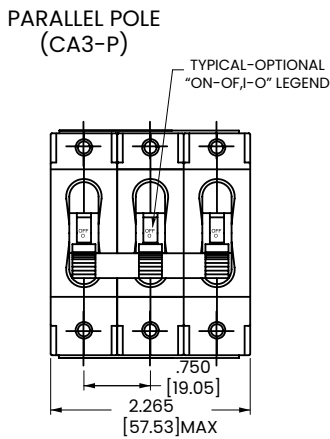
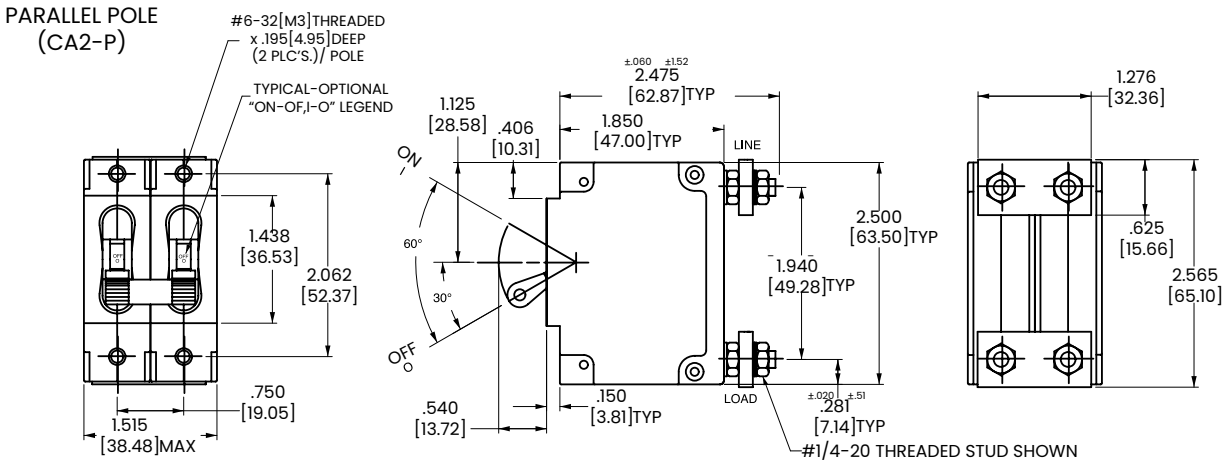

CIRCUIT BREAKER PROFILE	CIRCUIT SCHEMATIC (CA2-P SHOWN)		CIRCUIT CODE	SAFETY CODE
	ANSI	IEC		
<p>±.060 ±.152 1.388 [47.00] TYP</p>	<p>SWITCH TRIP</p>		P	0
<p>.400 [10.16]</p> <p>PUSH-IN STUD</p> <p>.255 [5.72]</p>	<p>SERIES TRIP WITH AUXILIARY SWITCH</p>		P	2 3 4

TERMINAL DETAILS

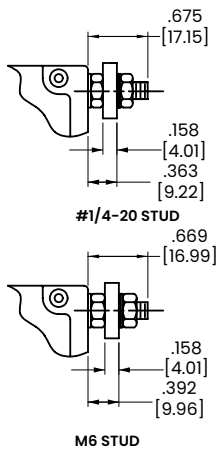
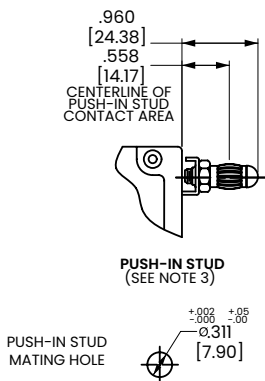

PANEL CUT-OUT DETAIL

TOLERANCE ±.005 [.12]

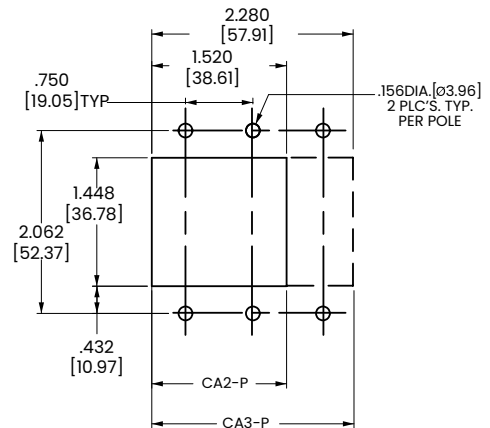

Notes:

1 Tolerance ±.020 [.51] unless otherwise specified.

Ordering Scheme

Sealed Toggle - UL 1077 Recognized

Sample Part Number

C M 3 - B 0 - 10 - 450 - 1 0 1 - C

Selection

1 2 3 4 5 6 7 8 9 10 11

1. SERIES

C

2. ACTUATOR ¹

M Sealed Toggle, one per pole

3. POLES

1 One 2 Two 3 Three

4. CIRCUIT

A ² Switch Only (no coil)	G ³ Relay Trip (voltage)
B Series Trip (current)	H ^{3,4} Dual Coil with Shunt Trip Voltage Coil
C Series Trip (voltage)	K ^{3,4} Dual Coil with Relay Trip Voltage Coil
D ³ Shunt Trip (current)	
E ³ Shunt Trip (voltage)	
F ³ Relay Trip (current)	

5. AUXILIARY / ALARM SWITCH ⁵

0 without Aux Switch	6 S.P.S.T., 0.139 Solder Lug
2 S.P.D.T., 0.110 Q.C. Term.	8 S.P.S.T., 0.187 Q.C. Term.
3 S.P.D.T., 0.139 Solder Lug	9 S.P.D.T., 0.187 Q.C. Term.
4 S.P.D.T., 0.110 Q.C. Term. (Gold Contacts)	

6. FREQUENCY & DELAY

03 ² DC 50/60Hz, Switch Only	30 DC 50/60Hz Instantaneous
10 ⁶ DC Instantaneous	31 DC 50/60Hz Ultra Short
11 DC Ultra Short	32 DC 50/60Hz Short
12 DC Short	34 DC 50/60Hz Medium
14 DC Medium	36 DC 50/60Hz Long
16 DC Long	42 ⁷ 50/60Hz Short, High-inrush
20 ⁶ 50/60Hz Instantaneous	44 ⁷ 50/60Hz Medium, High-inrush
21 50/60Hz Ultra Short	46 ⁷ 50/60Hz Long, High-inrush
22 50/60Hz Short	52 ⁷ DC Short, High-inrush
24 50/60Hz Medium	54 ⁷ DC Medium, High-inrush
26 50/60Hz Long	56 DC Long, High-inrush

Notes:

- Actuator Code M: Handle location as viewed from front of breaker:
2 pole - right pole 3 pole - center pole
- Switch Only circuits, rated up to 50 amps and 3 poles, and only available with VDE. For .02 to 30 amps, select Current Code 630. For 35 - 50 amps, select Current Code 650. For 55-70 amps, select Current Code 670. For 75-100 amps, select Current Code 810.
- Circuit Codes D,E,F,G,H & K available with Terminal Codes 1,2,4 & 5 only.
- Consult factory for available Dual Coil options, as special catalog number is required. Dual Coil Voltage Coils with Shunt Trip Construction trip instantaneously on line voltage. Dual Coil Voltage Coils require 30VA minimum power to trip instantaneously and are rated for intermittent duty only.
- Auxiliary Switch available with Series Trip and Switch Only circuits. On multipole breakers, one auxiliary switch is supplied, mounted in the extreme right pole.
- Voltage coils not rated for continuous duty. Available only with delay codes 10 & 20.
- Available with Circuit Codes B & D only, and up to 50 amps maximum.
- Consult factory for current ratings 71-100, in three pole units, available as special catalog number only.
- Terminal Code 1 available to 60 amps maximum.
- Terminal Codes 2, 4, 5 and C available to 50 amps maximum.
- Terminal Codes 3, 6 & 9 available to 100 amps maximum.
- Terminal Code 7 available to 25 amps maximum.
- Terminal Code A available to 100 amps maximum.

[Configure Complete Part Number >](#)

[Browse Standard Parts >](#)

7. CURRENT RATING (AMPERES) ⁹

CODE	AMPERES						
020	0.020	235	0.350	430	3.000	614	14.000
025	0.025	240	0.400	435	3.500	615	15.000
030	0.030	245	0.450	440	4.000	616	16.000
035	0.035	250	0.500	445	4.500	617	17.000
040	0.040	255	0.550	450	5.000	618	18.000
045	0.045	260	0.600	455	5.500	620	20.000
050	0.050	265	0.650	460	6.000	622	22.000
055	0.055	270	0.700	465	6.500	624	24.000
060	0.060	275	0.750	470	7.000	625	25.000
065	0.065	280	0.800	475	7.500	630	30.000
070	0.070	285	0.850	480	8.000	635	35.000
075	0.075	290	0.900	485	8.500	640	40.000
080	0.080	295	0.950	490	9.000	650	50.000
085	0.085	410	1.000	495	9.500	660	60.000
090	0.090	512	1.250	610	10.000	670	70.000
095	0.095	415	1.500	710	10.500	680	80.000
210	0.100	517	1.750	611	11.000	685	85.000
215	0.150	420	2.000	711	11.500	690	90.000
220	0.200	522	2.250	612	12.000	695	95.000
225	0.250	425	2.500	712	12.500	810	100.000
230	0.300	527	2.750	613	13.000		

OR VOLTAGE COIL (NORMAL RATED VOLTAGE) ⁶

A06 6 DC	A32 32 DC	J12 12 AC	J65 65 AC
A12 12 DC	A48 48 DC	J18 18 AC	K20 120 AC
A18 18 DC	A65 65 DC	J24 24 AC	L40 240 AC
A24 24 DC	J06 6 AC	J48 48 AC	

8. TERMINAL

1 Stud 10-32 ⁹	6 Stud M6 ¹¹
2 Screw 10-32 ¹⁰	7 0.250 Double Click Connect ¹²
3 Stud 1/4-20 ¹¹	9 7/16" Clip Terminal ¹¹
4 Stud M5 x 0.8 ¹⁰	A Plug-In Stud ¹³
5 Screw M5 x 0.8 ¹⁰	C 5/16" Clip Terminal ¹⁰

9. LEGEND PLATE

0 No Legend

10. MOUNTING / BARRIERS

	MOUNTING STYLE	BARRIERS
1	Standard Hex Nut	no
A	Standard Hex Nut (multi-pole units only)	yes

11. AGENCY APPROVAL

C	UL Recognized & CSA Accepted
I	UL Recognized & CSA Accepted, UL1500 ignition protection
L	UL Recognized & CSA Accepted with listed construction

Dimensional Specs Sealed Toggle

inches [millimeters]

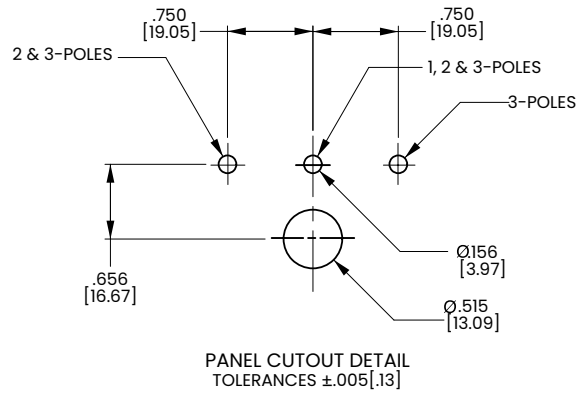
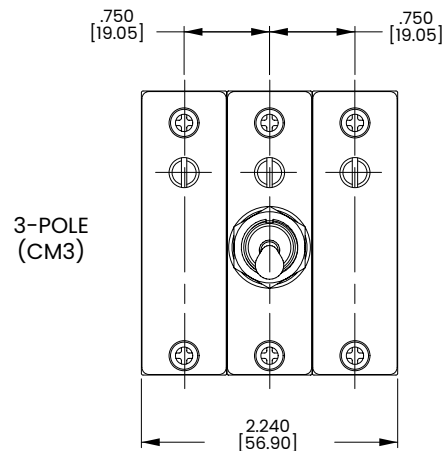
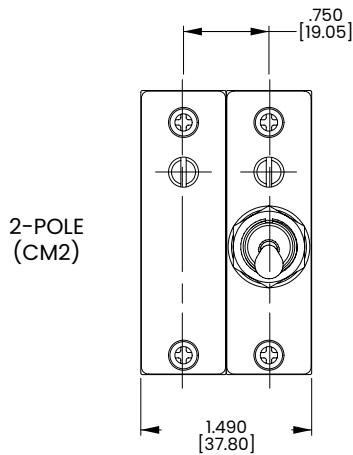
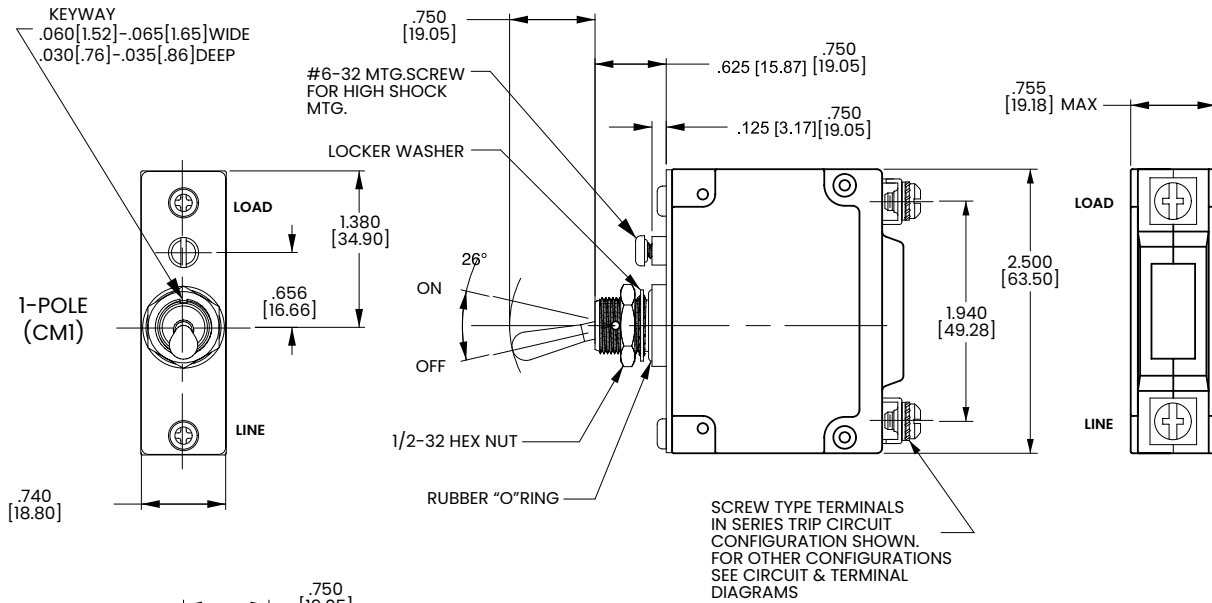

Notes:

- 1 Tolerance ±.020 [0.51] unless otherwise specified.

Ordering Scheme

Rocker - UL 1077 Recognized

Sample Part Number

C C 3 - B 0 - 14-450 - 1 2 1 - D

Selection 1 2 3 4 5 6 7 8 9 10 11

1. SERIES

C

2. ACTUATOR 1

Two Color Visi-Rocker

- C Indicate ON, vertical legend
- D Indicate ON, horizontal legend
- E Indicate ON, no legend
- F Indicate OFF, vertical legend
- G Indicate OFF, horizontal legend
- H Indicate OFF, no legend

Push-To-Reset, Visi-Rocker

- N Indicate OFF, vertical legend
- O Indicate OFF, horizontal legend
- P Indicate OFF, no legend

Single color

- J Vertical legend
- K Horizontal legend
- L No legend

Push-To-Reset, Single color

- R Vertical legend
- U Horizontal legend
- V No legend

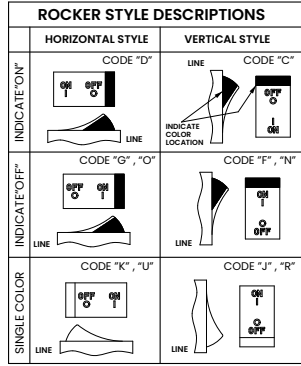

3. POLES 2

1 One 2 Two 3 Three

4. CIRCUIT

- | | |
|---------------------------------|---------------------------------|
| F 4 Relay Trip (Current) | D 4 Voltage Coil |
| A 3 Switch Only (No Coil) | D 4 Shunt Trip (Current) |
| G 4 Relay Trip (Voltage) | K 4,5 Dual Coil with Relay Trip |
| B Series Trip (Current) | E 4 Shunt Trip (Voltage) |
| H 4,5 Dual Coil with Shunt Trip | Voltage Coil |
| C Series Trip (Voltage) | |

5. AUXILIARY / ALARM SWITCH 6

- | | |
|------------------------------|------------------------------|
| 0 without Aux Switch | 8 S.P.S.T., 0.187 Q.C. Term. |
| 2 S.P.D.T., 0.110 Q.C. Term. | 4 S.P.D.T., 0.110 Q.C. Term. |
| 6 S.P.S.T., 0.139 Solder Lug | 9 S.P.D.T., 0.187 Q.C. Term. |
| 3 S.P.D.T., 0.139 Solder Lug | (Gold Contacts) |

6. FREQUENCY & DELAY

- | | |
|----------------------------|----------------------------------|
| 03 DC 50/60Hz, Switch Only | 30 DC 50/60Hz Instantaneous |
| 10 7 DC Instantaneous | 31 DC 50/60Hz Ultra Short |
| 11 DC Ultra Short | 32 DC 50/60Hz Short |
| 12 DC Short | 34 DC 50/60Hz Medium |
| 14 DC Medium | 36 DC 50/60Hz Long |
| 16 DC Long | 42 8 50/60Hz Short, High-inrush |
| 20 7 50/60Hz Instantaneous | 44 8 50/60Hz Medium, High-inrush |
| 21 50/60Hz Ultra Short | 46 8 50/60Hz Long, High-inrush |
| 22 50/60Hz Short | 52 8 DC Short, High-inrush |
| 24 50/60Hz Medium | 54 8 DC Medium, High-inrush |
| 26 50/60Hz Long | 56 8 DC Long, High-inrush |

Notes:

- 1 Push-To-Reset actuators have OFF portion of rocker shrouded.
- 2 Multi-pole breakers have all poles identical except when specifying Auxiliary switch and/or mixed poles, and have one rocker per breaker. Rocker location as viewed from front panel: 2 pole - left pole; 3 pole - center pole.
- 3 Switch Only circuits, rated up to 50 amps and 3 poles, and only available with VDE Certification when tied to a protected pole (Circuit Code B, C, D or H). For 02 to 30 amps, select Current Code 630. For 35 - 50 amps, select Current Code 650. For 55-70 amps, select Current Code 670. For 75-100 amps, select Current Code 810.
- 4 Circuit Codes D,E,F,G,H & K available with Terminal Codes 1,2,4 & 5 only. Circuit Codes D,F,H & K available up to 50 amps maximum Current Rating.
- 5 Consult factory for available Dual Coil options, as special catalog number is required. Dual Coil Voltage Coils with Shunt Trip Construction trip instantaneously on line voltage. Dual Coil Voltage Coils require 30VA minimum power to trip instantaneously and are rated for intermittent duty only.
- 6 Auxiliary Switch available with Series Trip and Switch Only circuits. On multipole breakers, one auxiliary switch is supplied, mounted in the extreme right pole. Auxiliary switch codes 2, 3 & 4 are VDE approved. Voltage coils not rated for continuous duty. Available only with delay codes 10 & 20.
- 7 Available with Circuit Codes B & D only, and up to 50 amps maximum. Current Ratings 60-70 are available up to four poles maximum. Ratings 71-100 are available up to two poles maximum.
- 8 Terminal Code 1 available to 60 amps maximum.
- 9 Terminal Codes 2,4,5 & C available to 50 amps maximum.
- 10 Terminal Codes 3,6 & 9 available to 100 amps maximum.
- 11 Terminal Code 7 available to 25 amps maximum.
- 12 Terminal Code A available to 100 amps maximum.
- 13 Terminal Codes 7, 9 & C are not VDE approved.
- 14 Color shown is visi-act legend with remainder of rocker black.
- 15 Legend on Push-to-reset bezel/shroud is white when single color rocker is ordered. Dual = ON-OFF/I-O legend with actuator codes C - G, and J, K, N, O, R, & U. None = no legend with actuator codes H, L, P, V. Rockerguard available with actuator codes C - L. Push-to-reset available with actuator codes N, O, P, R, U, V.
- 16 VDE/TUV approval requires Dual (I-O, ON-OFF) or I-O markings on rocker.
- 17 VDE/TUV: 30 amps max.; UL/CSA: 50 amps max.; Available in 2 - 4 poles only and limited to AC Delays. "General Purpose amps" not rated for "full load amps" or to be used in applications with a motor.

7. CURRENT RATING (AMPERES) 9

CODE	AMPERES	235	0.350	430	3.000	614	14.000
020	0.020	240	0.400	435	3.500	615	15.000
025	0.025	245	0.450	440	4.000	616	16.000
030	0.030	250	0.500	445	4.500	617	17.000
035	0.035	255	0.550	450	5.000	618	18.000
040	0.040	260	0.600	455	5.500	620	20.000
045	0.045	265	0.650	460	6.000	622	22.000
050	0.050	270	0.700	465	6.500	624	24.000
055	0.055	275	0.750	470	7.000	625	25.000
060	0.060	280	0.800	475	7.500	630	30.000
065	0.065	285	0.850	480	8.000	635	35.000
070	0.070	290	0.900	485	8.500	640	40.000
075	0.075	295	0.950	490	9.000	650	50.000
080	0.080	410	1.000	495	9.500	660 9	60.000
085	0.085	512	1.250	610	10.000	670 9	70.000
090	0.090	515	1.500	710	10.500	680 9	80.000
095	0.095	517	1.750	611	11.000	685 9	85.000
210	0.100	420	2.000	711	11.500	690 9	90.000
215	0.150	522	2.250	612	12.000	695 9	95.000
220	0.200	425	2.500	712	12.500	810 9	100.000
225	0.250	527	2.750	613	13.000		
230	0.300						

OR VOLTAGE COIL (NORMAL RATED VOLTAGE) 7

A06	6 DC	A32	32 DC	J12	12 AC	J65	65 AC
A12	12 DC	A48	48 DC	J18	18 AC	K20	120 AC
A18	18 DC	A65	65 DC	J24	24 AC	L40	240 AC
A24	24 DC	J06	6 AC	J48	48 AC		

8. TERMINAL

- | | |
|---------------------|---------------------------------|
| 1 Stud 10-32 10 | 6 Stud M6 12 |
| 2 Screw 10-32 11 | 7 0.250 Double Click Connect 13 |
| 3 Stud 1/4-20 12 | 9 7/16" Clip Terminal |
| 4 Stud M5 x 0.8 11 | A Plug-In Stud 14 |
| 5 Screw M5 x 0.8 11 | C 5/16" Clip Terminal |

9. ACTUATOR COLOR & LEGEND 16,17,18

Actuator or Visi-Color	Marking:	Marking Color:	Single Color	Rocker/Handle	Visi-Rocker
Color:	I-O ON-OFF Dual/None				
White	A B 1		Black	White	n/a
Black	C D 2		White	White	Red
Red	F G 3		White	White	Green
Green	H J 4		White	White	Blue
Blue	K L 5		White	White	Yellow
Yellow	M N 6		Black	Black	Gray
Gray	P Q 7		Black	Black	Orange
Orange	R S 8		Black	Black	

10 MOUNTING / BARRIERS 1

	STANDARD ROCKER BEZEL	BARRIERS	VOLTAGE
1	6-32 x 0.195 inches	no	<300
2	6-32 x 0.195 inches	yes	<300
3 19	6-32 x 0.195 inches	yes	≥300
4	ISO M3 x 5mm	no	<300
5	ISO M3 x 5mm	yes	<300
6 19	ISO M3 x 5mm	yes	≥300
ROCKERGUARD BEZEL			
A	6-32 x 0.195 inches	no	<300
C	6-32 x 0.195 inches	yes	<300
E 19	6-32 x 0.195 inches	yes	≥300
G	ISO M3 x 5mm	no	<300
J	ISO M3 x 5mm	yes	<300
L 19	ISO M3 x 5mm	yes	≥300
PUSH-TO-RESET BEZEL			
B	6-32 x 0.195 inches	no	<300
D	6-32 x 0.195 inches	yes	<300
F 19	6-32 x 0.195 inches	yes	≥300
H	ISO M3 x 5mm	no	<300
J	ISO M3 x 5mm	yes	<300
M 19	ISO M3 x 5mm	yes	≥300

11 AGENCY APPROVAL

C	UL Recognized & CSA Accepted
D	VDE Certified, UL Recognized & CSA Accepted
E	TUV Certified, UL Recognized & CSA Accepted
H	UL489 Construction: VDE Certified, UL Recognized & CSA Accepted
I	UL Recognized STD 1077, UL Recognized 1500 (ignition protected), & CSA Accepted
L	UL489 Construction: UL Recognized & CSA Accepted
R	UL489 Construction: TUV Certified, UL Recognized & CSA Accepted

Configure Complete Part Number >

Browse Standard Parts >

Ordering Scheme

Rocker - UL 489A Listed / Parallel Pole

Sample Part Number

C 1 2 - P 0 - D4 - 820 - 3 2 A - M T

Selection 1 2 3 4 5 6 7 8 9 10 11 12

1. SERIES

C

2. ACTUATOR ¹

- C** Curved Rocker, Two Color Visi, Indicate On, Vertical Legend
- D** Curved Rocker, Two Color Visi, Indicate On, Horizontal Legend
- F** Curved Rocker, Two Color Visi, Indicate Off, Vertical Legend
- G** Curved Rocker, Two Color Visi, Indicate Off, Horizontal Legend
- J** Curved Rocker, Single Color, Vertical Legend
- K** Curved Rocker, Single Color, Horizontal Legend
- N** Curved Rocker, Push To Reset, Two Color Visi, Vertical Legend
- O** Curved Rocker, Push To Reset, Two Color Visi, Horizontal Legend
- 1** Flat Rocker, Two Color Visi, Vertical Legend
- 2** Flat Rocker, Two Color Visi, Horizontal Legend
- 3** Flat Rocker, Single Color, Vertical Legend
- 4** Flat Rocker, Single Color, Horizontal Legend
- 5** Flat Rocker, Push To Reset, Two Color Visi, Vertical Legend
- 6** Flat Rocker, Push To Reset, Two Color Visi, Horizontal Legend
- 7** Flat Rocker, Push To Reset, Single Color, Vertical Legend
- 8** Flat Rocker, Push To Reset, Single Color, Horizontal Legend

3. POLES

- 1** One **2** Two **3** Three

4. CIRCUIT

- P** Series Trip (parallel pole)

5 AUXILIARY/ALARM SWITCH

- | | |
|---|---|
| 0 without Aux Switch | 6 S.P.S.T., 0.139 Solder Lug |
| 2 S.P.D.T., 0.110 Q.C. Term. | 7 S.P.S.T., 0.110 Q.C. Term. (Gold Contacts) |
| 3 S.P.D.T., 0.139 Solder Lug | 8 S.P.S.T., 0.187 Q.C. Term. (Gold Contacts) |
| 4 S.P.D.T., 0.110 Q.C. Term. (Gold Contacts) | 9 S.P.D.T., 0.187 Q.C. Term. (Gold Contacts) |
| 5 S.P.S.T., N.O., 0.110 Q.C. Term. (Gold Contacts) | |

6. FREQUENCY & DELAY

- D1** DC Ultra Short
- D2** DC Short
- D4** DC Medium
- D6** DC Long

7. CURRENT RATING (AMPERES) ²

CODE	AMPERES				
810	100.00	813	130.00	817	170.00
811	110.00	814	140.00	818	180.00
812	120.00	815	150.00	819	190.00
812	120.00	816	160.00	820	200.00
912	125.00			825	225.00
					250.00

8. TERMINAL ³

- 3** Stud 1/4-20
- 6** Stud M6
- A** Plug-In Stud ¹

9 ACTUATOR COLOR & LEGEND

Actuator Color	LEGEND	Dual	Legend Color
White	B ON-OFF	1	Black
Black	D	2	White
Red	G	3	White
Green	J	4	White
Blue	L	5	White
Yellow	N	6	Black
Gray	Q	7	Black
Orange	S	8	Black

10. MOUNTING

ROCKER / MOUNTING INSERT STYLE

- A** Standard Rocker Bezel - 6-32 Inserts
- B** Standard Rocker Bezel - M3 Inserts
- C** Rocker Guard Bezel - 6-32 Inserts
- D** Rocker Guard Bezel - M3 Inserts
- E** Standard Bezel with recessed Off Side Flat Rocker - 6-32 Inserts
- F** Standard Bezel with recessed Off Side Flat Rocker - M3 Inserts
- G** Push to Reset Bezel - 6-32 Inserts
- H** Push to Reset Bezel - M3 Inserts

11. MAXIMUM APPLICATION RATING

- M** 80 DC

12. AGENCY APPROVAL ⁴

- A** Without Approval
- G** UL489 Listed
- J** UL489A Listed, TUV Certified
- T** UL489A Listed
- 7** UL489A Listed, TUV Certified

Notes:

- ¹ Breakers with Terminal Codes 3 & 6 are supplied with bus bars connecting the Line and Load Terminals. For Terminal Code A, Line and Load Terminals must be connected to a copper bus bar having a minimum cross-section of 0.078 square inches. Terminal Code A is not available on the single pole unit.
- ² Ratings for 101 to 125 amps are available in 1-pole. Ratings from 110 to 200 amps are available in 2-pole. For ratings from 225-300 amps, specify 3-pole.
- ³ 1 pole only available with terminal codes 3 and 6.
- ⁴ Agency codes K and 7 are not available with 1 pole. Agency code J is only available with 1 pole. Agency code G is only available in 2 and 3 pole. Circuit P, ratings 101-150 amps (2 pole) and ratings 151-250 amps (3 pole).

[Configure Complete Part Number >](#)

[Browse Standard Parts >](#)

Ordering Scheme Rocker - UL 489 Listed

Sample Part Number **C C 3 - B 0 - 14 - 450 - 1 2 A - K G**

Selection 1 2 3 4 5 6 7 8 9 10 11 12

1. SERIES

C

2. ACTUATOR ¹

Two Color Visi-Rocker

- C Indicate ON, vertical legend
- D Indicate ON, horizontal legend
- F Indicate OFF, vertical legend
- G Indicate OFF, horizontal legend

Single color

- J Vertical legend
- K Horizontal legend

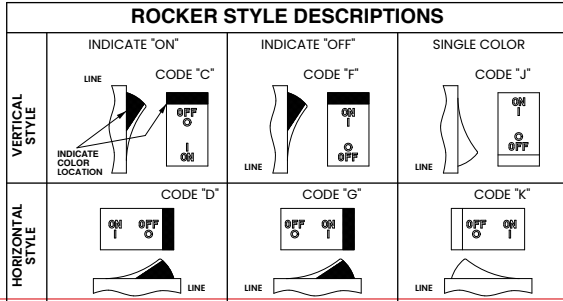

3. POLES ¹

- 1 One
- 2 Two
- 3 Three

4. CIRCUIT

- B Series Trip (current)

5 AUXILIARY/ALARM SWITCH ²

- 0 without Aux Switch
- 2 S.P.D.T., 0.110 Q.C. Term.
- 3 S.P.D.T., 0.139 Solder Lug
- 4 S.P.D.T., 0.110 Q.C. Term.
- 6 S.P.S.T., 0.139 Solder Lug
- 8 S.P.S.T., 0.187 Q.C. Term.
- 9 S.P.D.T., 0.187 Q.C. Term. (Gold Contacts)

6. FREQUENCY & DELAY

- 11 DC Ultra Short
- 12 DC Short
- 14 DC Medium
- 16 DC Long
- 21 50/60Hz Ultra Short
- 22 50/60Hz Short
- 24 50/60Hz Medium
- 26 50/60Hz Long
- 42⁸ 50/60Hz Short, High-inrush
- 44⁸ 50/60Hz Medium, High-inrush
- 46⁸ 50/60Hz Long, High-inrush
- 52⁸ DC Short, High-inrush
- 54⁸ DC Medium, High-inrush
- 56 DC Long, High-inrush

Notes:

- 1 Multi-pole breakers have all breakers identical except when specifying Auxiliary switch and/or mixed poles, and have one rocker per breaker.
- 2 On multi-pole breakers, one auxiliary switch is supplied, mounted in the extreme right pole.
- 3 Available up to 50 amps maximum.
- 4 Current ratings 71 - 100 with VDE approvals are available up to two poles maximum.
- 5 Terminal Code 1 available to 60 amps maximum.
- 6 Terminal Codes 2, 4, 5 & C available to 50 amps maximum.
- 7 Terminal Codes 3, 6, 9 & A available to 100 amps maximum.
- 8 Terminal Codes 9 & C are not VDE approved.
- 9 Color shown is visi and legend with remainder of rocker black
- 10 Dual = ON-OFF/I-O legend on actuator.
- 11 VDE and TUV approval requires Dual (I-O, ON-OFF) markings on rocker.
- 12 Rockerguard available with all actuator codes.
- 13 Barriers supplied on multi-pole units only.
- 14 2 & 3 pole circuit breakers required for 120/240 AC rating.

7. CURRENT RATING (AMPERES) ²

CODE	AMPERES	CODE	AMPERES	CODE	AMPERES	CODE	AMPERES
210	0.100	295	0.950	470	7.000	618	18.000
215	0.150	410	1.000	475	7.500	620	20.000
220	0.200	512	1.250	480	8.000	622	22.000
225	0.250	415	1.500	485	8.500	624	24.000
230	0.300	517	1.750	490	9.000	625	25.000
235	0.350	420	2.000	495	9.500	630	30.000
240	0.400	522	2.250	610	10.000	635	35.000
245	0.450	425	2.500	710	10.500	640	40.000
250	0.500	527	2.750	611	11.000	650	50.000
255	0.550	430	3.000	711	11.500	660	60.000
260	0.600	435	3.500	612	12.000	670	70.000
265	0.650	440	4.000	712	12.500	680	80.000
270	0.700	445	4.500	613	13.000	685	85.000
275	0.750	450	5.000	614	14.000	690	90.000
280	0.800	455	5.500	615	15.000	695	95.000
285	0.850	460	6.000	616	16.000	810	100.000
290	0.900	465	6.500	617	17.000		

8. TERMINAL ³

- 1 Stud 10-32 ⁵
- 2 Screw 10-32 with saddle ⁶
- 3 Stud 1/4-20 ⁷
- 4 Stud M5 x 0.8 ⁶
- 5 Screw M5 x 0.8 with saddle & washer clamps ⁶
- 6 Stud M6 ⁷
- 9 7/16" Clip Terminal & washer clamps ^{7,8}
- A Plug-In Stud ^{7,8}
- C 5/16" Clip Terminal ^{6,8}

9. ACTUATOR COLOR & LEGEND

Actuator or Visi-Color	Marking:	Marking Color:	Single Color Rocker/Handle	Visi-Rocker
Color:	ON-OFF	Dual ¹⁰	Black	White
White	B	1	White	n/a
Black	D	2	White	Red
Red	G	3	White	Green
Green	J	4	White	Blue
Blue	L	5	White	Yellow
Yellow	N	6	Black	Gray
Gray	Q	7	Black	Orange
Orange	S	8	Black	

10. MOUNTING / BARRIERS ¹²

	Standard Rocker Bezel Threaded Insert, 2 per pole	BARRIERS ¹³
A	6-32 X 0.195 inches	yes
C	ISO M3 x 5mm	yes
	Rockerguard Bezel Threaded Insert, 2 per pole	
B	6-32 x 0.195 inches	yes
D	ISO M3 x 5mm	yes

11. MAXIMUM APPLICATION RATING

- B 125 DC
- C 120/240 AC ¹⁴
- D 240 AC
- F 277 AC
- K 120 AC
- M 80 DC

12. AGENCY APPROVAL

- A without approvals
- F UL 489 Listed, CSA Certified, & VDE Certified
- G UL 489 Listed & CSA Certified
- J UL 489 Listed, CSA Certified & TUV Certified

[Configure Complete Part Number >](#)

[Browse Standard Parts >](#)

Circuit & Terminal Diagrams Rocker

inches [millimeters]

CIRCUIT BREAKER PROFILE	CIRCUIT SCHEMATIC		CIRCUIT CODE	AUX SWITCH CODE	CIRCUIT SCHEMATIC		CIRCUIT CODE	AUX SWITCH CODE
	ANSI	IEC			ANSI	IEC		
<p>SERIES TRIP (2 TERM'S.) ± 0.031 [±.79] 625 [5.88] TYP</p>	SWITCH ONLY (NO COIL) LINE LOAD LINE (NETZ) LOAD (LAST)		A	0	SWITCH TRIP LINE LOAD LINE (NETZ) (3) LOAD (LAST)		BC	0
<p>SERIES TRIP W/AUX. SWITCH (5 TERM'S.) 675 [17.15] TYP 970 [24.64] 1,265 [32.13] AUX. SWITCH TERM'S. (3 PLCS.)</p>	SWITCH ONLY (NO COIL) WITH AUXILIARY SWITCH LINE LOAD LINE (NETZ) LOAD (LAST)		A	2 3 4	SERIES TRIP WITH AUXILIARY SWITCH LINE LOAD LINE (NETZ) (3) LOAD (LAST)		BC	2 3 4
<p>SHUNT TRIP (3 TERM'S.)</p>	SHUNT TRIP LINE SHUNT LOAD LINE (NETZ) (3) SHUNT (NEBENSCHLUSS) LOAD (LAST)		DE	0	DUAL COIL: SERIES TRIP CURRENT COIL, SHUNT TRIP VOLTAGE COIL LINE SHUNT LOAD LINE (NETZ) SHUNT (NEBENSCHLUSS) LOAD (LAST) VOLTAGE COIL VOLTAGE COIL		H	0
<p>SHUNT TRIP (4 TERM'S.) ± 0.031 [±.79] 812 [20.62] TYP 646 [16.41] TYP</p>	RELAY TRIP LINE LOAD RELAY RELAY LINE (NETZ) RELAY (RELAIS) LOAD (LAST)		FG	0	DUAL COIL: SERIES TRIP CURRENT COIL, RELAY TRIP VOLTAGE COIL LINE LOAD RELAY RELAY LINE (NETZ) RELAY (RELAIS) LOAD (LAST) VOLTAGE COIL VOLTAGE COIL		K	0

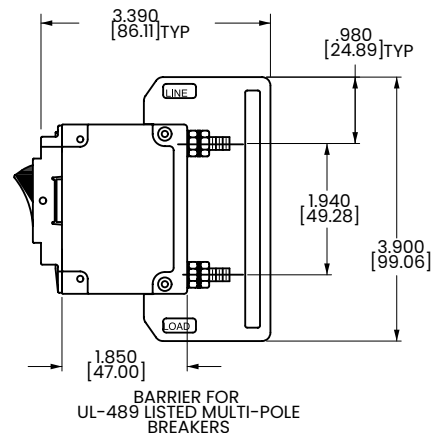
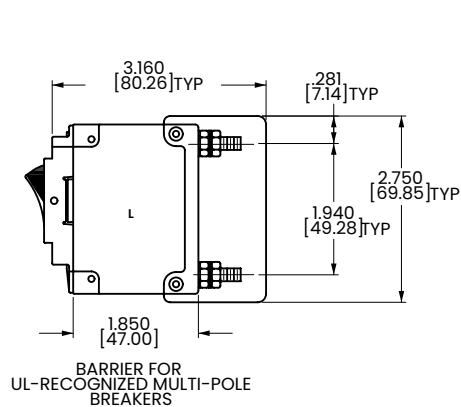

- Notes:
- 1 Tolerance ± 0.020 [.51] unless otherwise specified.
 - 2 Schematic shown represents current trip circuit.

Dimensional Specs Rocker

inches [millimeters]

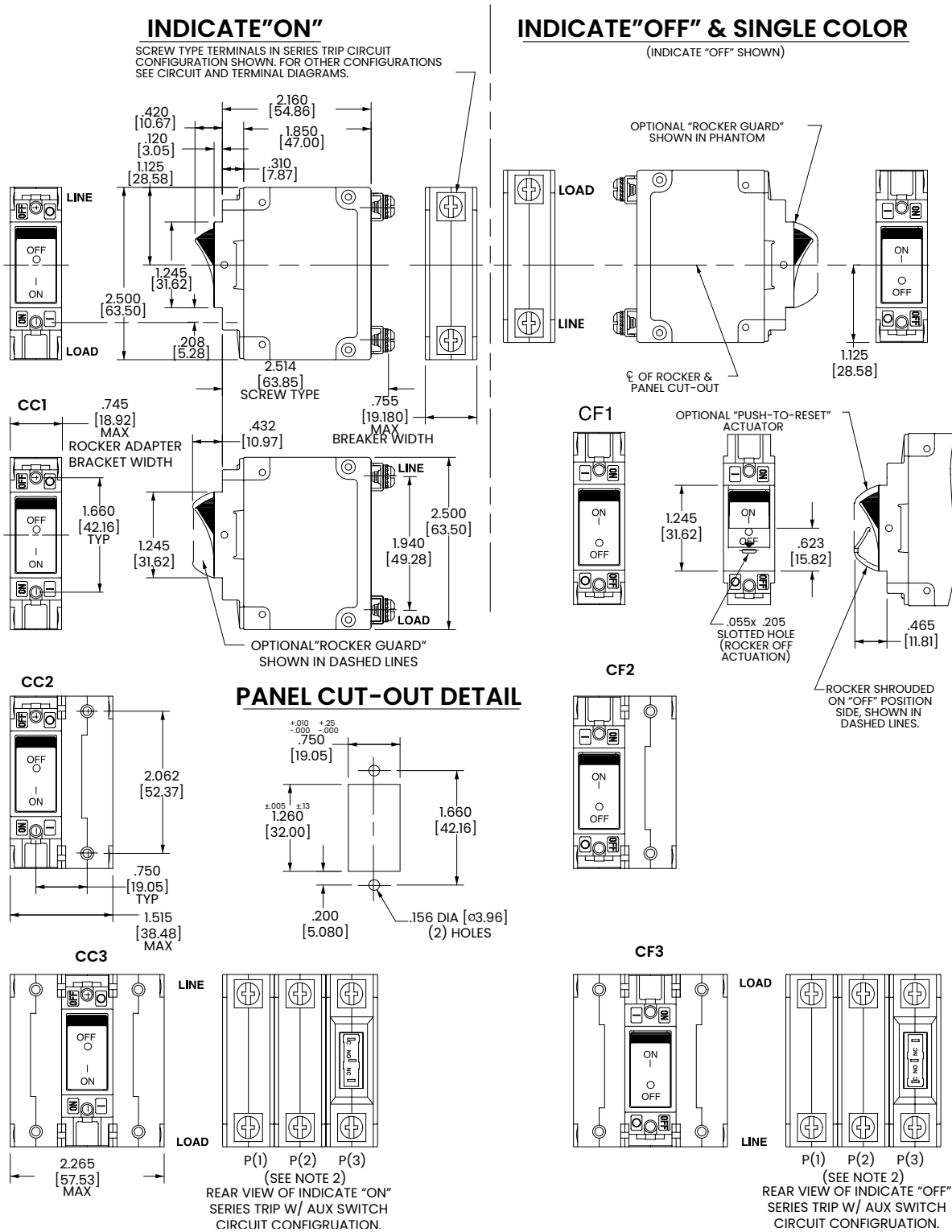

Notes:

- 1 Dimensions apply to all variations shown. Notice that circuit breaker line and load terminal orientation on indicate OFF is opposite of indicate ON.
- 2 For pole orientation with horizontal legend, rotate front view clockwise 90°.
- 3 Tolerance ±.020 [.51] unless otherwise specified.

Ordering Scheme

Flat Rocker - UL 1077 Recognized

Sample Part Number

C 1 2 - B 0 - 10-450 - 1 2 1 - E

Selection 1 2 3 4 5 6 7 8 9 10 11

1. SERIES

C

2. ACTUATOR ¹

- 1 Two Color Visi-Rocker
- 2 Indicate OFF, vertical legend
- 3 Indicate OFF, horizontal legend
- 4 Single color vertical legend
- 5 Horizontal legend
- 6 Push-To-Reset, Visi-Rocker
- 7 Indicate OFF, vertical legend
- 8 Indicate OFF, horizontal legend
- 9 Push-To-Reset, Single color vertical legend
- 10 Horizontal legend

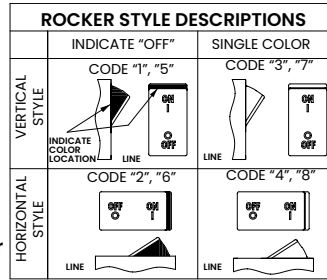

3. POLES ²

- 1 One
- 2 Two
- 3 Three

4. CIRCUIT

- F ⁴ Relay Trip (Current)
- A ³ Switch Only (No Coil)
- G ⁴ Relay Trip (Voltage)
- B Series Trip (Current)
- H ^{4,5} Dual Coil with Shunt Trip
- C Series Trip (Voltage)
- D ⁴ Shunt Trip (Current)
- K ^{4,5} Dual Coil with Relay Trip
- E ⁴ Shunt Trip (Voltage)
- Voltage Coil

5. AUXILIARY / ALARM SWITCH ⁶

- 0 without Aux Switch
- 2 S.P.D.T., 0.110 Q.C. Term.
- 3 S.P.D.T., 0.139 Solder Lug
- 4 S.P.D.T., 0.110 Q.C. Term. (Gold Contacts)
- 6 S.P.S.T., 0.139 Solder Lug
- 8 S.P.S.T., 0.187 Q.C. Term.
- 9 S.P.D.T., 0.187 Q.C. Term.

6. FREQUENCY & DELAY

- 03 DC 50/60Hz, Switch Only
- 10 ⁷ DC Instantaneous
- 11 DC Ultra Short
- 12 DC Short
- 14 DC Medium
- 16 DC Long
- 20 ⁷ 50/60Hz Instantaneous
- 21 50/60Hz Ultra Short
- 22 50/60Hz Short
- 24 50/60Hz Medium
- 26 50/60Hz Long
- 30 DC 50/60Hz Instantaneous
- 31 DC 50/60Hz Ultra Short
- 32 DC 50/60Hz Short
- 34 DC 50/60Hz Medium
- 36 DC 50/60Hz Long
- 42 ⁸ 50/60Hz Short, High-inrush
- 44 ⁸ 50/60Hz Medium, High-inrush
- 46 ⁸ 50/60Hz Long, High-inrush
- 52 ⁸ DC Short, High-inrush
- 54 ⁸ DC Medium, High-inrush
- 56 ⁸ DC Long, High-inrush

Notes:

- 1 Push-to-reset actuators have OFF portion of rocker shrouded.
- 2 Multi-pole breakers have all poles identical except when specifying Auxiliary switch and/or mixed poles, and have one rocker per breaker. Rocker location as viewed from front panel: 2 pole - left pole; 3 pole - center pole.
- 3 Switch Only circuits, rated up to 50 amps and 3 poles, and only available with VDE Certification when tied to a protected pole (Circuit Code B, C, D or H). For .02 to 30 amps, select Current Code 630. For 35 - 50 amps, select Current Code 650. For 55-70 amps, select Current Code 670. For 75-100 amps, select Current Code 810.
- 4 Circuit Codes D,E,F,G,H & K available with Terminal Codes 1,2,4 & 5 only. Circuit Codes D,F,H & K available up to 50 amps maximum Current Rating. Consult factory for available Dual Coil options, as special catalog number is required. Dual Coil Voltage Coils with Shunt Trip Construction trip instantaneously on line voltage. Dual Coil Voltage Coils require 30VA minimum power to trip instantaneously and are rated for intermittent duty only.
- 6 Auxiliary Switch available with Series Trip and Switch Only circuits. On multipole breakers, one auxiliary switch is supplied, mounted in the extreme right pole. Auxiliary switch codes 2, 3 & 4 are VDE approved.
- 7 Voltage coils not rated for continuous duty. Available only with delay codes 10 and 20.
- 8 Available with Circuit Codes B & D only, and up to 50 amps maximum.
- 9 Current ratings 60-70 are available up to four poles maximum. Current ratings 71 - 100 are available up to two poles maximum.
- 10 Terminal Code 1 available to 60 amps maximum.
- 11 Terminal Codes 2,4,5 & C available to 50 amps maximum.
- 12 Terminal Codes 3,6 & 9 available to 100 amps maximum.
- 13 Terminal Code 7 available to 25 amps maximum.
- 14 Terminal Code A available to 100 amps maximum.
- 15 Terminal Codes 7, 9 & C are not VDE approved.
- 16 Color shown is visi & legend with remainder of rocker black. Dual = ON-OFF/I-O legend.
- 17 Legend on Push-to-reset bezel/shroud is white with single color actuator codes 7 & 8. Legend on Push-to-reset bezel/shroud matches visi-color of rocker with actuator codes 5 & 6.
- 18 VDE/TUV approval requires Dual (I-O, ON-OFF) or I-O markings on rocker.
- 19 VDE/TUV: 30 amps max; UL/CSA: 50 amps max; Available in 2 & 3 poles only and limited to AC Delays. "General Purpose amps" not rated for "full load amps" or to be used in applications with a motor.
- 20 Recessed "OFF SLIDE" available with actuator codes 1,2,3&4. Legends on rocker are available in ink stamping only.

7. CURRENT RATING (AMPERES) ⁹

CODE	AMPERES	020	025	030	035	040	045	050	055	060	065	070	075	080	085	090	095	210	215	220	225	230	
	0.020	235	0.350	430	3.000	614	14.000																
	0.025	240	0.400	435	3.500	615	15.000																
	0.030	245	0.450	440	4.000	616	16.000																
	0.035	250	0.500	445	4.500	617	17.000																
	0.040	255	0.550	450	5.000	618	18.000																
	0.045	260	0.600	455	5.500	620	20.000																
	0.050	265	0.650	460	6.000	622	22.000																
	0.055	270	0.700	465	6.500	624	24.000																
	0.060	275	0.750	470	7.000	625	25.000																
	0.065	280	0.800	475	7.500	630	30.000																
	0.070	285	0.850	480	8.000	635	35.000																
	0.075	290	0.900	485	8.500	640	40.000																
	0.080	295	0.950	490	9.000	650	50.000																
	0.085	410	1.000	495	9.500	660	60.000																
	0.090	512	1.250	610	10.000	670	70.000																
	0.095	415	1.500	710	10.500	680	80.000																
	0.100	517	1.750	611	11.000	685	85.000																
	0.150	420	2.000	711	11.500	690	90.000																
	0.200	522	2.250	612	12.000	695	95.000																
	0.250	425	2.500	712	12.500	810	100.000																
	0.300	527	2.750	613	13.000																		

OR VOLTAGE COIL (NORMAL RATED VOLTAGE) ⁷

Code	Voltage	Code	Voltage	Code	Voltage
A06	6 DC	A32	32 DC	J12	12 AC
A12	12 DC	A48	48 DC	J18	18 AC
A18	18 DC	A65	65 DC	J24	24 AC
A24	24 DC	J06	6 AC	J48	48 AC
				J65	65 AC
				K20	120 AC
				L40	240 AC

8. TERMINAL

- 1 Stud 10-32 ¹⁰
- 2 Screw 10-32 with saddle ¹¹
- 3 Stud 1/4-20 ¹²
- 4 Stud M5 x 0.8 ¹¹
- 5 Screw M5 x 0.8 ¹¹
- 6 Stud M6 ¹²
- 9 7/16" Clip Terminal
- 7 0.250 Double Click Connect ¹³
- A Plug-In Stud ¹⁴
- C 5/16" Clip Terminal

9. ACTUATOR COLOR & LEGEND ^{16,17,18}

Actuator or Visi-Color	Marking:	Marking:	Color:
	Color	Color	Color
	I-O ON-OFF	Dual/None	Single Color
	A B	1	White
	C D	2	Black
	F G	3	White
	H J	4	White
	K L	5	White
	M N	6	Black
	P Q	7	Black
	R S	8	Black
			White
			n/a
			Red
			Green
			Blue
			Yellow
			Gray
			Orange

10 MOUNTING / BARRIERS ¹

STANDARD ROCKER BEZEL	BARRIERS	VOLTAGE
1 6-32 x 0.195 inches	no	<300
2 6-32 x 0.195 inches	yes	<300
3 ¹⁹ 6-32 x 0.195 inches	yes	≥300
4 ISO M3 x 5mm	no	<300
5 ISO M3 x 5mm	yes	<300
6 ¹⁹ ISO M3 x 5mm	yes	≥300
ROCKERGUARD BEZEL		
A 6-32 x 0.195 inches	no	<300
C 6-32 x 0.195 inches	yes	<300
E ¹⁹ 6-32 x 0.195 inches	yes	≥300
G ISO M3 x 5mm	no	<300
J ISO M3 x 5mm	yes	<300
L ¹⁹ ISO M3 x 5mm	yes	≥300
PUSH-TO-RESET BEZEL		
B 6-32 x 0.195 inches	no	<300
D 6-32 x 0.195 inches	yes	<300
F ¹⁹ 6-32 x 0.195 inches	yes	≥300
H ISO M3 x 5mm	no	<300
J ISO M3 x 5mm	yes	<300
M ¹⁹ ISO M3 x 5mm	yes	≥300

11 AGENCY APPROVAL

- C UL Recognized & CSA Accepted
- E TUV Certified, UL Recognized & CSA Accepted
- I UL Recognized STD 1077, UL Recognized 1500 (ignition protected), & CSA Accepted
- L UL489 Construction: UL Recognized & CSA Accepted
- R UL489 Construction: TUV Certified, UL Recognized & CSA Accepted

Ordering Scheme Flat Rocker - UL 489 Listed

Sample Part Number **C 1 2 - B 0 - 14 - 450 - 1 2 A - K G**

Selection 1 2 3 4 5 6 7 8 9 10 11 12

1. SERIES

C

2. ACTUATOR 1

Two Color Visi-Rocker

- 1 Indicate OFF, vertical legend
- 2 Indicate OFF, horizontal legend

Single color

- 3 Vertical legend
- 4 Horizontal legend

Push-To-Reset, Visi-Rocker

- 5 Indicate OFF, vertical legend
- 6 Indicate OFF, horizontal legend

Push-To-Reset, Single color

- 7 Vertical legend
- 8 Horizontal legend

ROCKER STYLE DESCRIPTIONS

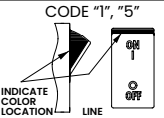
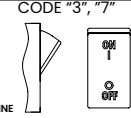
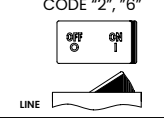
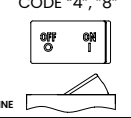
	INDICATE "OFF"	SINGLE COLOR
VERTICAL STYLE	 <p>CODE "1", "5"</p>	 <p>CODE "3", "7"</p>
HORIZONTAL STYLE	 <p>CODE "2", "6"</p>	 <p>CODE "4", "8"</p>

3. POLES 2

- 1 One
- 2 Two
- 3 Three

4. CIRCUIT

- B Series Trip (current)

5 AUXILIARY/ALARM SWITCH 2

- 0 without Aux Switch
- 2 S.P.D.T., 0.110 Q.C. Term.
- 3 S.P.D.T., 0.139 Solder Lug
- 4 S.P.D.T., 0.110 Q.C. Term. (Gold Contacts)
- 6 S.P.S.T., 0.139 Solder Lug
- 8 S.P.S.T., 0.187 Q.C. Term.
- 9 S.P.D.T., 0.187 Q.C. Term.

6. FREQUENCY & DELAY

- 11 DC Ultra Short
- 12 DC Short
- 14 DC Medium
- 16 DC Long
- 21 50/60Hz Ultra Short
- 22 50/60Hz Short
- 24 50/60Hz Medium
- 26 50/60Hz Long
- 42⁴ 50/60Hz Short, High-inrush
- 44⁴ 50/60Hz Medium, High-inrush
- 46⁴ 50/60Hz Long, High-inrush
- 52⁴ DC Short, High-inrush
- 54⁴ DC Medium, High-inrush
- 56⁴ DC Long, High-inrush

Notes:

- 1 Push-to-reset actuators have OFF portion of rocker shrouded.
- 2 Multi-pole breakers have all breakers identical except when specifying Auxiliary switch and/or mixed poles, and have one rocker per breaker.
- 3 On multi-pole breakers, one auxiliary switch is supplied, mounted in the extreme right pole.
- 4 Available up to 50 amps maximum.
- 5 Current ratings 71 - 100 with VDE approvals are available up to two poles maximum.
- 6 Terminal Code 1 available to 60 amps maximum.
- 7 Terminal Codes 2, 4, 5 & C available to 50 amps maximum.
- 8 Terminal Codes 3, 6, 9 & A available to 100 amps maximum.
- 9 Terminal Codes 9 & C are not VDE approved.
- 10 Color shown is visi and legend with remainder of rocker black
- 11 Dual = ON-OFF/I-O legend on actuator.
- 12 TUV approval requires Dual (I-O, ON-OFF) markings on rocker.
- 13 Legend on push-to-reset bezel/shroud is white when single color rocker is ordered. Legend on push-to-reset bezel/shroud matches visi-color of rocker with actuator codes 5 & 6.
- 14 Recessed "OFF-SIDE" available with actuator codes 1, 2, 3, & 4. Legends on rocker are available in ink stamping only.
- 15 Barriers supplied on multi-pole units only.
- 16 2 & 3 pole circuit breakers required for 120/240 AC rating.

7. CURRENT RATING (AMPERES) 5

CODE	AMPERES	CODE	AMPERES	CODE	AMPERES	CODE	AMPERES
210	0.100	295	0.950	470	7.000	618	18.000
215	0.150	410	1.000	475	7.500	620	20.000
220	0.200	512	1.250	480	8.000	622	22.000
225	0.250	415	1.500	485	8.500	624	24.000
230	0.300	517	1.750	490	9.000	625	25.000
235	0.350	420	2.000	495	9.500	630	30.000
240	0.400	522	2.250	610	10.000	635	35.000
245	0.450	425	2.500	710	10.500	640	40.000
250	0.500	527	2.750	611	11.000	650	50.000
255	0.550	430	3.000	711	11.500	660	60.000
260	0.600	435	3.500	612	12.000	670	70.000
265	0.650	440	4.000	712	12.500	680	80.000
270	0.700	445	4.500	613	13.000	685	85.000
275	0.750	450	5.000	614	14.000	690	90.000
280	0.800	455	5.500	615	15.000	695	95.000
285	0.850	460	6.000	616	16.000	810	100.000
290	0.900	465	6.500	617	17.000		

8. TERMINAL

- 1 Stud 10-32⁶
- 2 Screw 10-32 with saddle⁷
- 3 Stud 1/4-208
- 4 Stud M5 x 0.8⁷
- 5 Screw M5 x 0.8⁷
- 6 Stud M6⁸
- 9 7/16" Clip Terminal^{8,9}
- A Plug-In Stud⁸
- C 5/16" Clip Terminal^{7,9}

9 ACTUATOR COLOR & LEGEND 10

Actuator or Visi-Color	Marking:	Marking Color:	Single Color Rocker/Handle	Visi-Rocker
Color:	ON-OFF	Dual ¹⁰		
White	B	1	Black	White
Black	D	2	White	n/a
Red	G	3	White	Red
Green	J	4	White	Green
Blue	L	5	White	Blue
Yellow	N	6	Black	Yellow
Gray	Q	7	Black	Gray
Orange	S	8	Black	Orange

10. MOUNTING / BARRIERS

	STANDARD ROCKER BEZEL Threaded Insert, 2 per pole	BARRIERS ¹⁵
A	6-32 X 0.195 inches	yes
C	ISO M3 x 5mm	yes
	RECESSED OFF ROCKER¹⁴ Threaded Insert, 2 per pole	
E	6-32 x 0.195 inches	yes
F	ISO M3 x 5mm	yes
	PUSH-TO-RESET BEZEL¹³ Threaded Insert, 2 per pole	
B	6-32 x 0.195 inches	yes
D	ISO M3 x 5mm	yes

11. MAXIMUM APPLICATION RATING

- B 125 DC
- C 120/240 AC¹⁶
- D 240 AC
- F 277 AC
- K 120 AC
- M 80 DC

12. AGENCY APPROVAL 12

- A without approvals
- G UL 489 Listed & CSA Certified
- J UL489 Listed, CSA Certified & TUV Certified

Configure Complete Part Number >

Browse Standard Parts >

Dimensional Specs Flat Rocker

inches [millimeters]

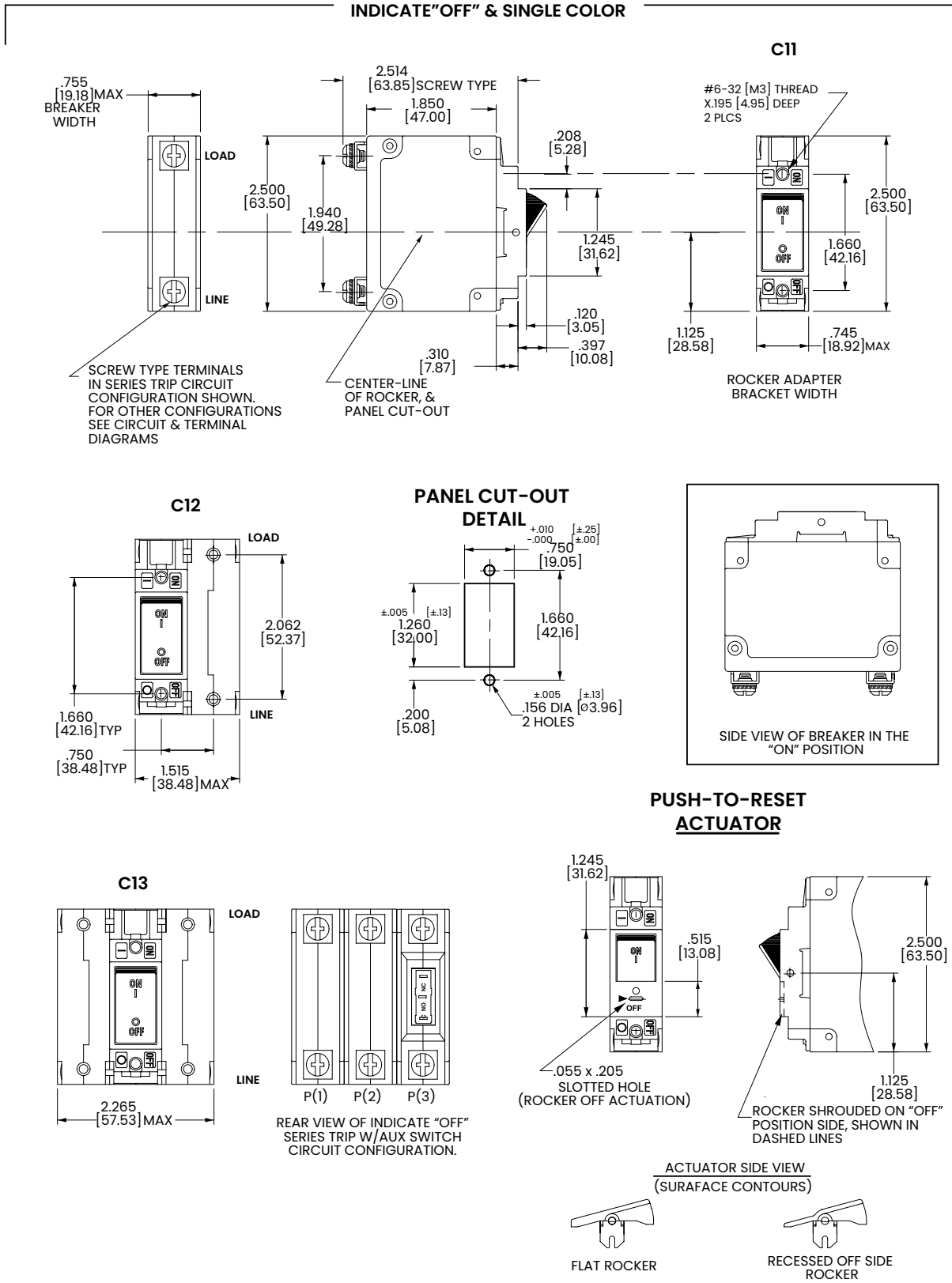

- Notes:
- 1 For pole orientation with horizontal legend, rotate front view clockwise 90°.
 - 2 Tolerance ±.020 [.51] unless otherwise specified.

Authorized Sales Representatives and Distributors

Click on a region of the map below to find your local representatives and distributors or visit www.carlingtech.com/findarep.



About Carling

Founded in 1920, Carling Technologies is a leading manufacturer of electrical and electronic switches and assemblies, circuit breakers, electronic controls, power distribution units, and multiplexed power distribution systems. With six ISO9001 and IATF16949 registered manufacturing facilities and technical sales offices worldwide, Carling Technologies Sales, Service and Engineering teams do much more than manufacture electrical components, they engineer powerful solutions! To learn more about Carling please visit www.carlingtech.com/company-profile.

To view all of Carling's environmental, quality, health & safety certifications please visit www.carlingtech.com/environmental-certifications.

Mouser Electronics

Authorized Distributor

Click to View Pricing, Inventory, Delivery & Lifecycle Information:

Carling Technologies:

[CA2-B0-34-650-121-D](#) [CA2-B0-34-650-121-C](#) [C12-B0-34-645-131-E](#) [CA2-B0-34-450-121-D](#) [CA1-B0-34-640-121-C](#)
[C12-B0-34-450-131-E](#) [C12-B0-34-650-131-E](#) [CA1-B0-34-610-121-D](#) [CA1-B0-34-610-121-C](#) [C12-B0-34-630-131-E](#)
[C11-B0-34-625-131-E](#) [CA2-B0-34-615-121-D](#) [C11-B0-34-620-131-E](#) [CA1-B0-34-450-121-C](#) [CA1-B0-34-650-121-D](#)
[CF1-B2-12-690-33A-C](#) [CA1-B0-34-450-121-D](#) [CA1-B0-34-650-121-C](#) [C11-B0-34-650-131-E](#) [C12-B0-34-620-131-E](#)
[C11-B0-34-630-131-E](#) [C12-B0-34-640-131-E](#) [CA1-B0-34-615-121-D](#) [CA1-B0-34-615-121-C](#) [CA1-B0-34-630-121-D](#)
[CA1-B0-34-630-121-C](#) [CA2-B0-34-610-121-C](#) [CA2-B0-34-610-121-D](#) [C12-B0-34-610-131-E](#) [C12-B0-34-615-131-E](#)
[CA2-B0-34-640-121-C](#) [C12-B0-34-635-131-E](#) [C12-B0-34-625-131-E](#) [CA2-B0-34-620-121-C](#) [CA2-B0-34-620-121-D](#)
[CA1-B0-34-620-121-D](#) [CA1-B0-34-620-121-C](#) [CA2-B0-34-630-121-C](#) [CA2-B0-34-630-121-D](#) [CA2-B0-46-615-622-E](#)
[CM1-B0-34-610-101-C](#) [CM1-B0-34-615-101-C](#) [CM1-B0-34-620-101-C](#) [CM1-B0-34-625-101-C](#) [CM1-B0-34-630-101-C](#)
[CM1-B0-34-645-101-C](#) [CM1-B0-34-650-101-C](#) [CT1-X0-07-695-121-MJ](#) [CA1-B0-26-620-121-C](#) [CA1-B0-34-810-321-C](#)
[CA2-B0-24-650-121-D](#) [CA2-B0-34-650-321-C](#) [CA3-B0-21-650-12A-C](#) [CA3-B0-22-650-12A-D](#) [CA3-B0-24-650-321-C](#)
[CA3-B0-34-450-121-D](#) [CA3-B0-34-610-121-D](#) [CA3-B0-34-615-121-D](#) [CA3-B0-34-620-121-C](#) [CA3-B0-34-620-121-D](#)
[CA3-B0-34-630-121-C](#) [CA3-B0-34-640-121-C](#) [CA3-B0-34-650-121-C](#) [CA3-B0-34-650-121-D](#) [CB3-X0-04-626-11C-D](#)
[CB4-X0-04-053-11C-D](#) [CD1-B0-14-810-33A-C](#) [CJ2-B2-26-650-33J-D](#) [CJ2-B2-26-670-33J-D](#) [CT1-B2-14-810-321-MG](#)
[CC2-B0-22-650-33C-D](#) [CA2-B0-24-620-121-CG](#) [CA2-B0-22-630-121-D](#) [CJ2-B0-24-630-331-D](#) [CA1-B2-10-650-321-C](#)
[CA3-B0-22-650-12A-H](#) [CM1-B2-12-670-301-C](#) [CM1-B2-12-810-301-C](#) [CM1-B2-12-630-101-C](#) [CM3-X0-21-024-101-C](#)
[CA1-D0-10-210-121-C](#) [CA2-B0-24-650-121-CG](#) [CF1-X0-22-404-X1A-C](#) [CF1-X0-06-034-X1A-C](#) [CF1-X0-06-032-X1A-C](#)
[CT1-B2-14-630-321-MG](#) [CS1-B0-24-620-122-DG](#) [CA1-B0-11-625-322-C](#) [CA2-B0-26-660-311-R](#) [CB3-B0-24-650-1DA-C](#)
[CG1-B2-12-640-31B-MG](#) [CB3-X0-10-072-42D-C](#) [CG1-B2-12-630-31B-MG](#) [CD2-B0-24-615-121C-G](#)
[CA1-B0-14-810-321-C](#) [CA1-B0-24-610-121-KG](#) [CA2-B0-34-650-622-C](#) [CM1-B2-12-450-101-C](#) [C21-B0-24-650-21E-KJ](#)
[C22-B0-24-630-21E-CJ](#)