



Housing Material: Polyester, Black UL94V-0  
 Contacts: Phosphor Bronze 30µin Au plating over Ni  
 Leads: Matte Sn over Ni  
 Shield: Cu Alloy with Ni plating 40µin min  
 Durability: 1000 mating cycles  
 Dimensions: Inch [mm]



**PART NO. : HFJ11-1G02E-L11RL**

FASTJACK™ WITH 1000BASE-T MAGNETICS  
 RoHS COMPLIANT  
 COMPATIBLE TO LEAD-FREE WAVE SOLDERING PROCESS FOR THROUGH HOLE COMPONENTS  
 OPERATING TEMPERATURE 0/70°C

**ELECTRICAL SPECIFICATIONS @ 25° C**

URNS RATIO	1:1 ±3%
ACL (100KHz,0.1V,8mA)	350µH min
INSERTION LOSS 1-100MHz	-1.1dB max
RETURN LOSS 1-40MHz	-18dB min
60MHz	-14dB min
80MHz	-12dB min
100MHz	-10dB min
CROSSTALK 1-100MHz	-35dB typ
CMR 0.1-30MHz	-38dB typ
30-60MHz	-35dB typ
60-100MHz	-30dB typ
ISOLATION	1,500Vrms

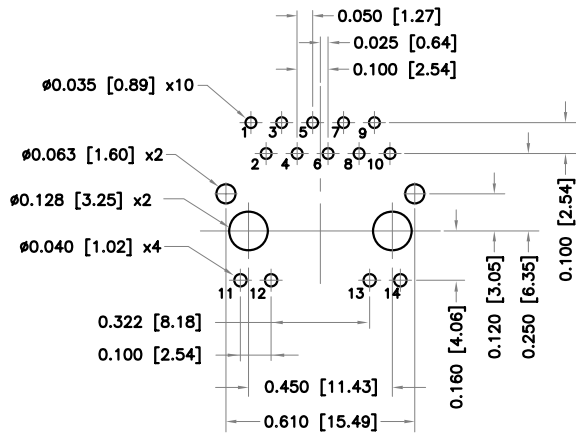
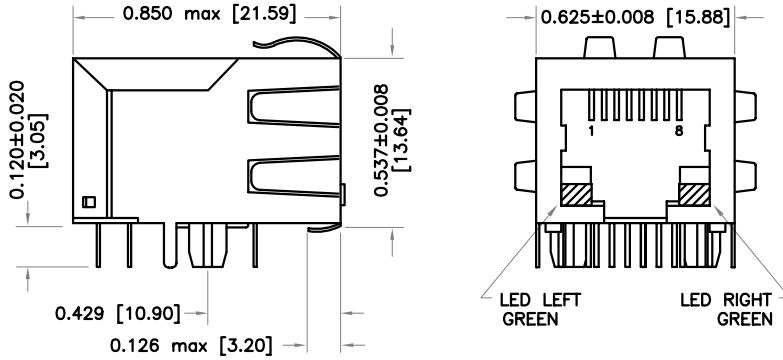

RECOMMENDED P.C. BOARD PATTERN (COMP. SIDE)

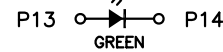
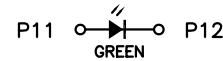

LED FORWARD VOLTAGE/  
 CURRENT: 2.1V/10mA typ

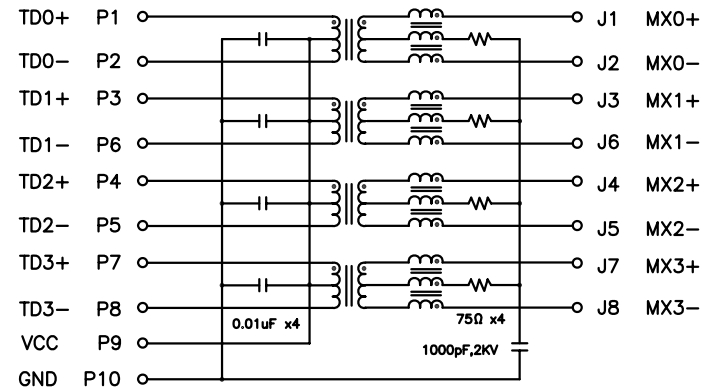

LINE



**HALO/PBL**

CALIFORNIA, USA  
 KOWLOON, HONG KONG  
 SINGAPORE

TITLE	FastJack™ SINGLE	SIGNATURES	DATE	REV.	DESC.	DATE
FOR	GIGABIT ETHERNET	DRAWN	PETER LU	6/21/06	A	FIRST ISSUE
PART NO.	HFJ11-1G02E-L11RL	CHECKED	LEI KEONG	6/20/09	B	PROD. RELEASE
SCALE	NONE	APPROVED	PETER LU	6/20/09		
PAGE	1 OF 1	FILE	1G02E-L11RL.DWG			

# Mouser Electronics

Authorized Distributor

Click to View Pricing, Inventory, Delivery & Lifecycle Information:

[HALO Electronics:](#)

[HFJ11-1G02E-L11RL](#)