

Applicable cable	
Items	Applicable condition
Conductor size	AWG 28-22
Insulation O.D.	Ø1.55mm max.
Braid Shield	Tin plating
Sheath O.D.	Ø6.3mm - Ø7.2mm

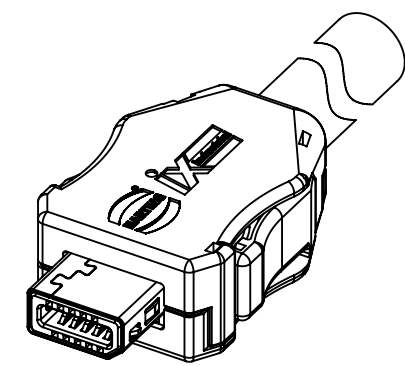
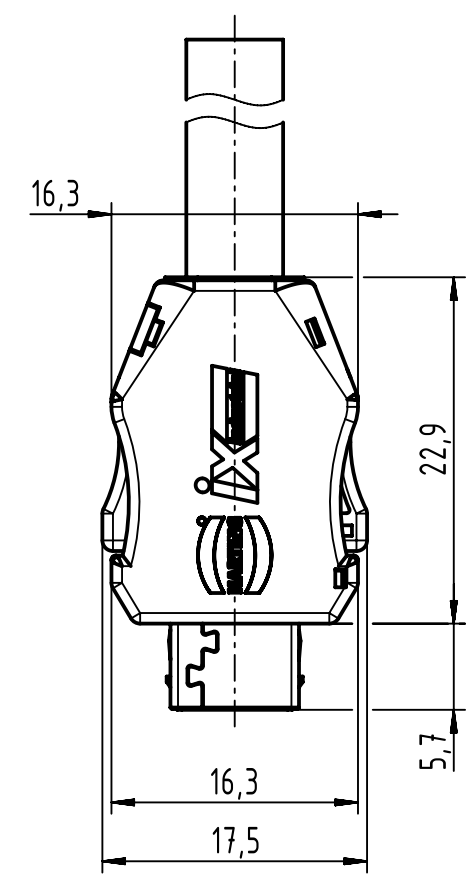

Contact material: copper alloy
 Contact area: Gold 0.2µm min.
 Wiring area: Gold 0.03µm min.
 Under plating: Nickel 2µm min.

	All Dimensions in mm Original Size DIN A4	Scale 2:1	Free size tol.		Ref.	
	All rights reserved Department EC PD - RO	Created by POPESCUD	Inspected by PRIESTER	Standardisation HOFFMANN	Date 2017-10-19	State Final Release
HARTING Electronics GmbH D-32339 Espelkamp		Title ix Ind plug; Cat.6A 10p solder; B key			Doc-Key / ECM-Nr. 100744234/UGD/000/A 500000126069	
		Type TB	Number 09451819000		Rev. A	Page 1/2

Shield Shell delivery form

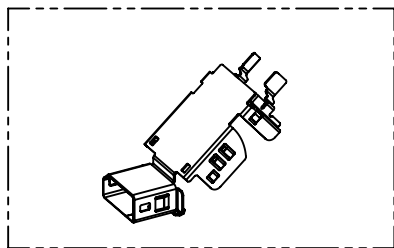

Product Structure

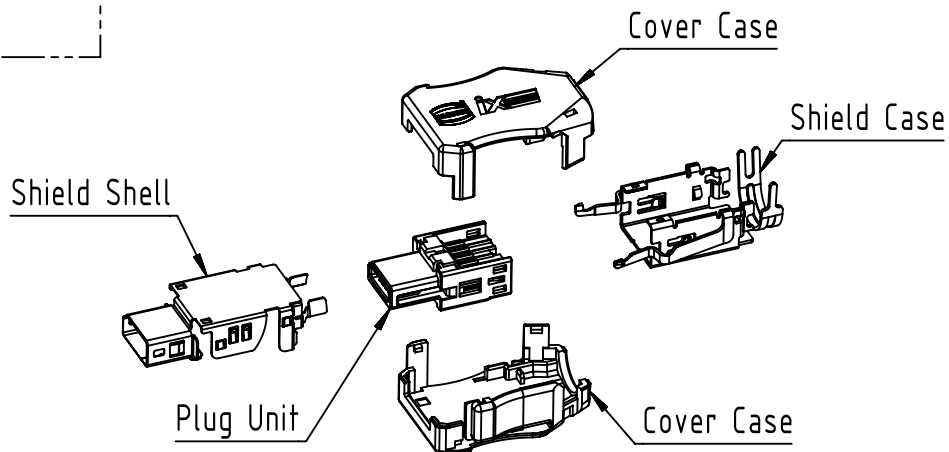

Plug Unit

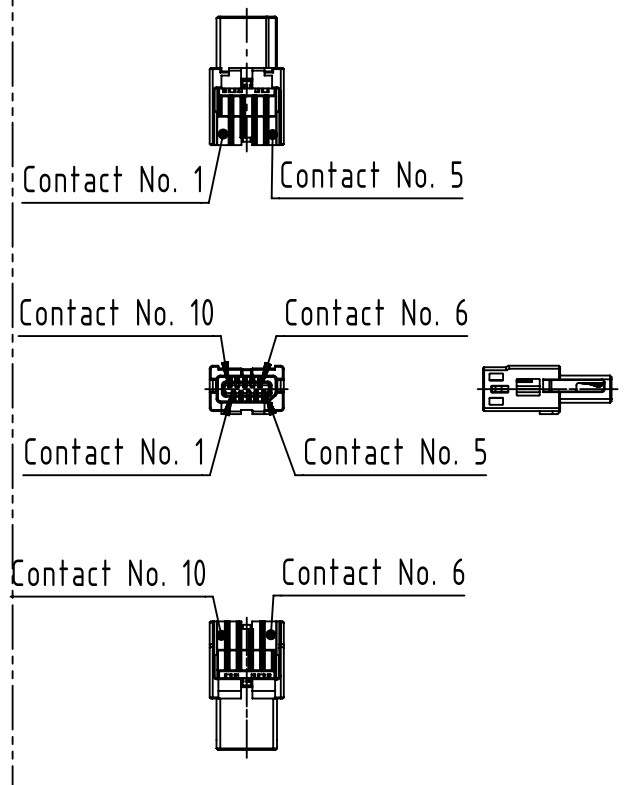

Mating condition (2:1)

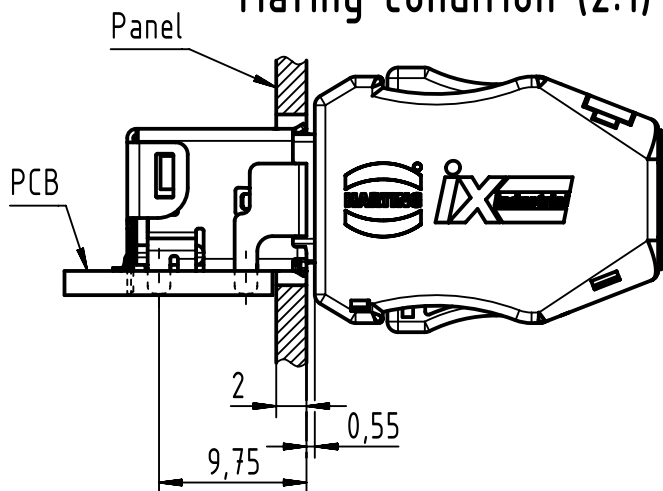

	All Dimensions in mm Original Size DIN A4	Scale 1:1	Free size tol.		Ref.		
	All rights reserved Department EC PD - RO	Created by POPESCUD	Inspected by PRIESTER	Standardisation HOFFMANN	Date 2017-10-19	State Final Release	
Title ix Ind plug; Cat.6A 10p solder; B key					Doc-Key / ECM-Nr. 100744234/UGD/000/A 500000126069		
HARTING Electronics GmbH D-32339 Espelkamp		Type TB	Number 09451819000			Rev. A	Page 2/2

Mouser Electronics

Authorized Distributor

Click to View Pricing, Inventory, Delivery & Lifecycle Information:

[HARTING:](#)

[09451819000XL](#)