

ALUMINUM ELECTROLYTIC CAPACITORS

UDB

Bi-Polarized, For Speaker Network



- Bi-polarized series.
- Designed specifically for crossover networks in Hi-Fi sound systems.
- Compliant to the RoHS directive (2011/65/EU,(EU)2015/863).

Specifications

Item	Performance Characteristics
Category Temperature Range	-40 to +85°C
Rated Voltage Range	50V
Rated Capacitance Tolerance	±20% at 1kHz
Leakage Current (After 5 minutes' application of rated voltage at 20°C)	Leakage current is not more than 0.03CV or 3 (μA), whichever is greater.
Tangent of loss angle (tan δ) (1 kHz) (5 kHz)	0.10 or less 0.15 or less
Allowable Continuous Current (8Ω - f _c)	Value in table or less
Marking	Printed with white color letter on black sleeve.

Radial Lead Type

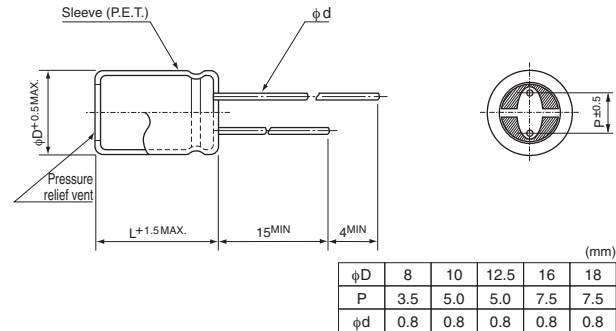

• Please refer to page 18 about the end seal configuration.

Type numbering system (Example : UDB 50V 10μF)

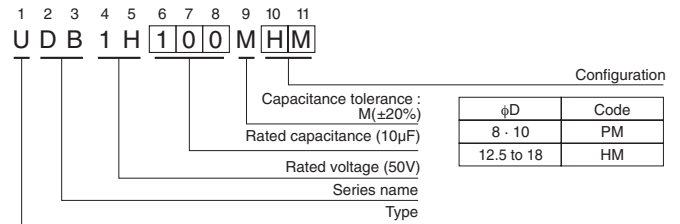

Dimensions

Rated Voltage (V) (code)	Rated Capacitance (μF)	Case Size φD×L (mm)	tan δ		Leakage Current (μA) (at 20°C after 5 minutes)	Allowable Continuous Current (8Ω - f _c)		Part Number
			1kHz	5kHz		Frequency (Hz)	Rated ripple (mArms)	
50 (1H)	1	8×11.5	0.10	0.15	3	20k	205	UDB1H010MPM
	1.5	8×11.5	0.10	0.15	3	13k	245	UDB1H1R5MMPM
	2.2	10×12.5	0.10	0.15	3.3	9k	320	UDB1H2R2MMPM
	3.3	10×16	0.10	0.15	4.95	6k	400	UDB1H3R3MMPM
	4.7	10×20	0.10	0.15	7.05	4.2k	480	UDB1H4R7MMPM
	6.8	12.5×20	0.10	0.15	10.2	2.9k	540	UDB1H6R8MHM
	10	12.5×25	0.10	0.15	15	2k	600	UDB1H100MHM
	15	12.5×25	0.10	0.15	22.5	1.3k	660	UDB1H150MHM
	22	16×25	0.10	0.15	33	900	740	UDB1H220MHM
	33	16×31.5	0.10	0.15	49.5	600	800	UDB1H330MHM
47	18×35.5	0.10	0.15	70.5	420	1020	UDB1H470MHM	

For cut leads, formed leads or taped parts, please add the appropriate code after the size code (12th digit).
If there is no size code in the part number, please add size code "1" and then add the appropriate code.

Please refer to page 18, 19 about the formed or taped product spec.
Please refer to page 4 for the minimum order quantity.

● Dimension table in next page.

Mouser Electronics

Authorized Distributor

Click to View Pricing, Inventory, Delivery & Lifecycle Information:

Nichicon:

[UDB1H100MHB](#) [UDB1H150MHB](#) [UDB1H6R8MHB](#) [UDB2A2R7KPDANATD](#) [UDB1H100MRB](#) [UDB1H010MPM](#)
[UDB1H100MHM](#) [UDB1H150MHM](#) [UDB1H1R5MPM](#) [UDB1H220MHM](#) [UDB1H330MHM](#) [UDB1H470MHM](#)
[UDB1H4R7MPM](#) [UDB1H680MRM](#) [UDB1H6R8MHM](#) [UDB2A2R7KPAANATD](#) [UDB1H2R2MPM](#) [UDB1H3R3MPM](#)
[UDB1H4R7MPM1TD](#) [UDB1H3R3MPM1TD](#) [UDB1H010MPM1TD](#) [UDB1H6R8MHM1TO](#) [UDB1H100MHM1TO](#)
[UDB1H150MHM1TO](#) [UDB1H1R5MPM1TD](#) [UDB1H220MHM1TN](#) [UDB1H2R2MPM1TD](#) [UDB1H1R5MPM1TA](#)
[UDB1H010MPM1TA](#)