

15/40/80CN Series

Medium Pressure Filters

Max 320 l/min - 70 bar



Global Filtration Technology

Medium Pressure Filters

15/40/80CN Series

TYPICAL APPLICATIONS

- Compressor Lube Oil
- Off-line Filter Loops
- Machine Tools (Automotive Standard)
- Hydrostatic Drive Charge Pumps
- Mobile Equipment
- Pilot Lines For Servo Controls
- Oil Patch Drilling Equipment
- Injection Moulding

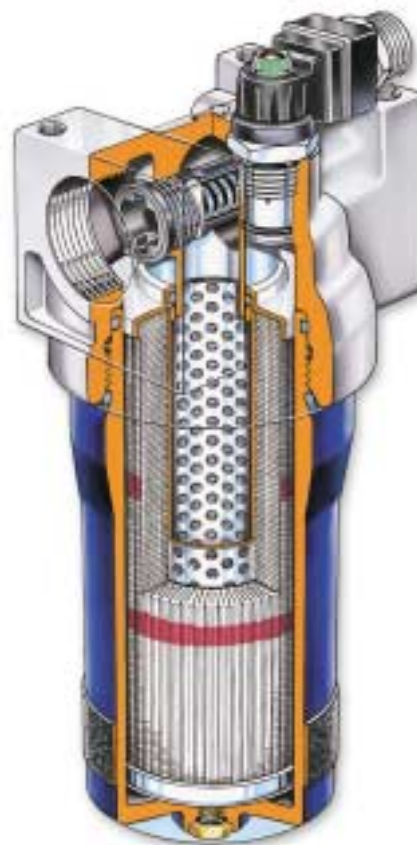

The Parker Filtration 15/40/80CN Series Medium Pressure Filters.

This partial list of applications for Parker “CN” Series Filters has a common factor, the need for an economical, medium pressure range filter with excellent fatigue pressure ratings. Prior to the availability of the “CN” filter, applications such as those listed were restricted by limitations of a spin-on can, or forced into the higher-cost range of high pressure filters.

The “CN” Series fills this gap, and now with the newly increased fatigue rating from 40 to 56 bar the applications are expanded.

FEATURES	ADVANTAGES	BENEFITS
<ul style="list-style-type: none"> • 56 bar fatigue rating eight times that of a spin-on) 	<ul style="list-style-type: none"> • Ability to provide reliable service under tough cyclic operating conditions • Can be utilised in applications where high pressure filters may have been only option 	<ul style="list-style-type: none"> • Reduced downtime due to premature filter failures • Reduced costs, better “fit” for the application
<ul style="list-style-type: none"> • Diametral (side) seal between head and bowl 	<ul style="list-style-type: none"> • Proven reliability in cyclic applications • Reduced importance of bowl torque 	<ul style="list-style-type: none"> • No downtime, no leaks • Performs with “real world” service
<ul style="list-style-type: none"> • Dust Seal 	<ul style="list-style-type: none"> • Prevents contamination from building up on bowl/head threads 	<ul style="list-style-type: none"> • Easier service, eliminates thread galling
<ul style="list-style-type: none"> • 40CN-2 meets automotive H3 standard • 15CN meets automotive HF2 standard 	<ul style="list-style-type: none"> • Automotive industry acceptance 	<ul style="list-style-type: none"> • Satisfies specifications without need for further testing and/or approval
<ul style="list-style-type: none"> • Cast aluminium head 	<ul style="list-style-type: none"> • Low profile, lightweight and durable 	<ul style="list-style-type: none"> • Less weight, smaller envelop and cleaner appearance
<ul style="list-style-type: none"> • Reinforced Microglass III replacement elements 	<ul style="list-style-type: none"> • Multi-layered design produced high capacity and efficiency • Wire support reduces pleat bunching, keeps performance consistent 	<ul style="list-style-type: none"> • Great performance value • Reliable performance throughout element life • Reduces downtime, maximises element life
<ul style="list-style-type: none"> • Complete performance data disclosure 	<ul style="list-style-type: none"> • All pertinent information is provided in an easy-to-compare format 	<ul style="list-style-type: none"> • No hidden deficiencies • Easy selection of proper filtration
<ul style="list-style-type: none"> • Visual, electrical or electrical/visual indicators available 	<ul style="list-style-type: none"> • Check element condition at a glance • Right style for the application 	<ul style="list-style-type: none"> • Optimise element life, prevent bypassing • Matches your system electrical connections

*Fluoroelastomers are available under various registered trademarks, including Viton (a registered trademark of DuPont) and Fluorel (a registered trademark of 3M)

SPECIFICATION

Maximum Allowable Operating Pressure:
70 bar

Operating Temperature Range:
-26°C to 135°C (Fluoroelastomer Seals)
-42°C to 107°C (Nitrile)

Materials of Construction:
Aluminium head, hard anodized aluminium bowl

Filtration Media:
Microglass III. (See Table 4). For E Series consult Parker Filtration

Ports:
Inlet and outlet ports are threaded internally, flange faced ports available on 80CN

Port Style	Model	15CN	40CN	80CN
BSPF(G)		1", 3/4"	1 1/4", 1 1/2"	1 1/2", 2"
SAE		12, 16	16, 24	24, 32
ISO 6149		M27	M33	M42, M48
Metric 3000-M config				2"

Bypass Valve & Indicator Settings:
Table following gives bypass valve and corresponding indicator

setting

Bypass	Indicator
1.7 bar	1.2 bar
3.5 bar	2.5 bar

Weights (Kg):

Model	Length 1	Length 2
15CN	1.1	1.6
40CN	2.0	2.5
80CN	5.6	6.9

Fluid Compatability:

Suitable for use with mineral and vegetable oils, and some synthetic oils. For other fluids, please consult Parker Filtration

Seal Material:

Nitrile or Fluoroelastomer*

Electrical Ratings:

Power - 5 VA max, Current - 0.25 A max (resistive), Voltage - 28 VDC max, 28 VAC (50-60Hz) max, Contacts - normally open and normally closed, wired to DIN plug pin code (option code E2 only)

DIMENSIONS (mm)

MODEL	A	B	C	D	E	F	G	H	I	J	K	L	M	N	P
15CN	156.6 (6.17)	250.7 (9.87)	46.5 (1.83)	25.4 (1.09)	71.1 (2.80)	85.9 (3.38)	73.2 (2.88)	82.6 (3.25)	38.1 (1.50)	22.9 (0.90)	42.9 (1.69)	36.6 (1.44)	60.5	4xM6-1.0x7.9 DEEP	15-20 ft lbs
40CN	170.8 (6.73)	262.4 (10.33)	62.0 (2.44)	32.6 (1.28)	107.2 (4.22)	127.0 (5.00)	111.0 (4.37)	121.9 (4.80)	62.0 (2.44)	31.8 (1.25)	58.8 (2.32)	60.2 (2.37)	60.5	4xM8-1.25x13 DEEP	45-50 ft lbs
80CN	280.9 (11.06)	401.6 (15.81)	77.7 (3.06)	49.5 (1.95)	124.8 (4.91)	158.7 (6.25)	82.6 (3.25)	151.4 (5.96)	101.6 (4.00)	41.1 (1.62)	79.4 (3.12)	41.3 (1.63)	60.5	4xM8-1.25x16 DEEP	60-70 ft lbs

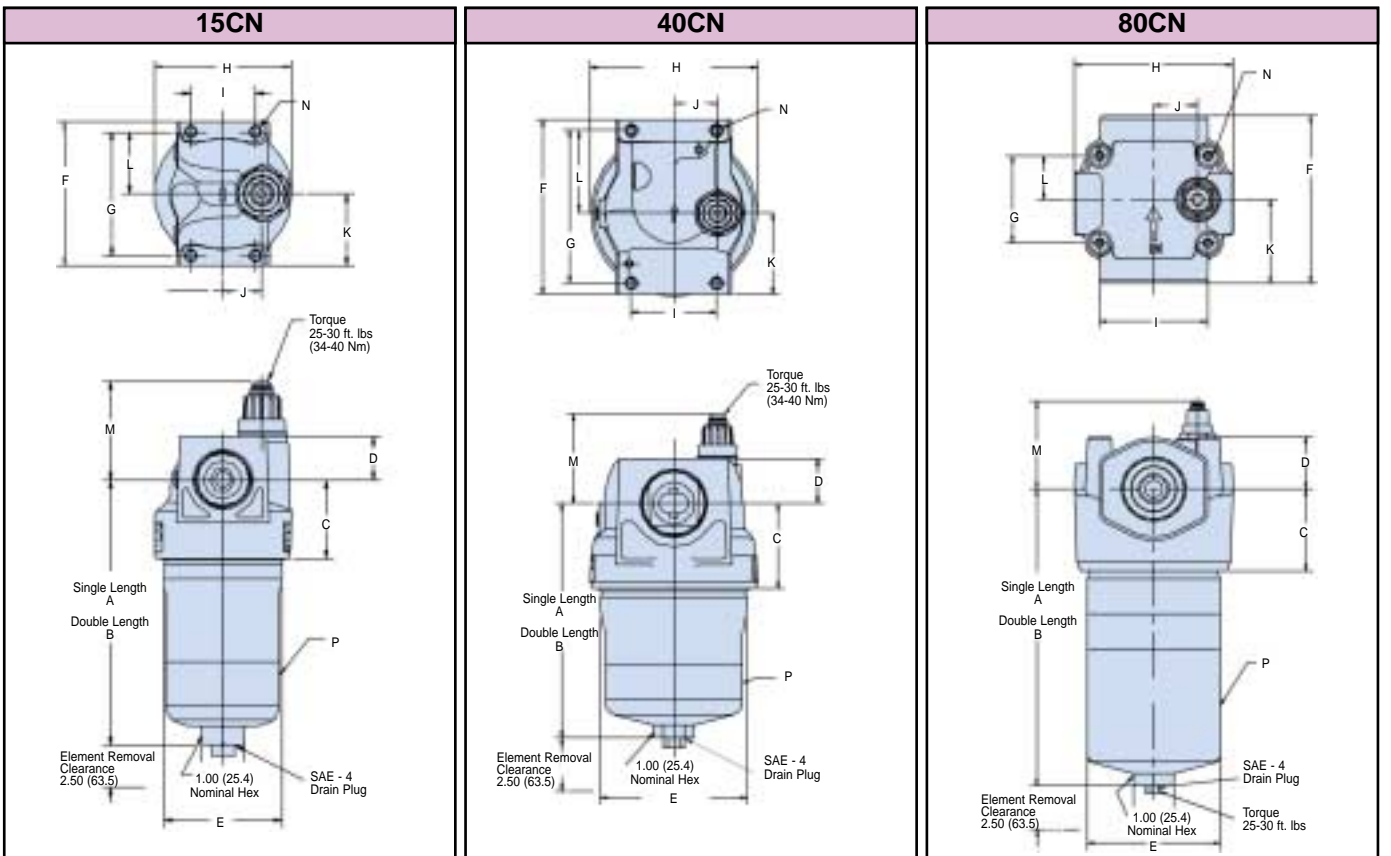

Medium Pressure Filters

15/40/80CN Series

80CN FLANGE FACE DETAILS

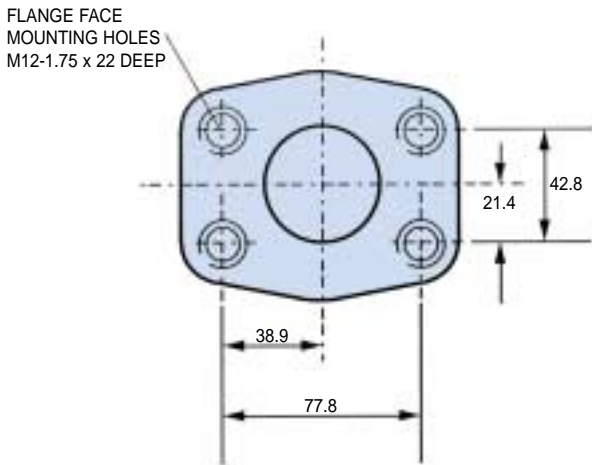

INDICATOR DETAILS

**Visual/Electrical Indicator
CODE E2**

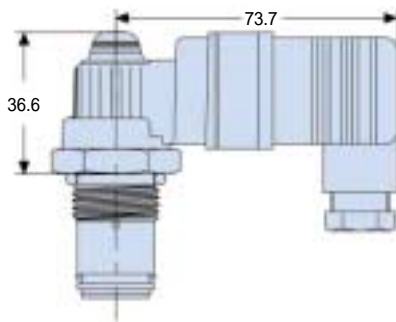

**Visual Indicator
CODE M2**

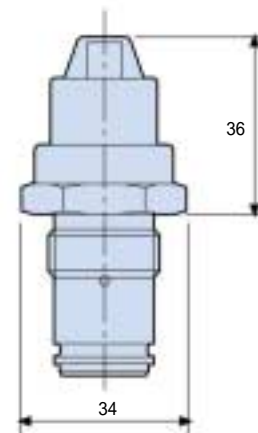

Option	Description	Connection/Voltage	Wiring	Part Number						
M2	Visual Auto Reset	N/A	N/A	932026 (1.7 bar)						
				932027 (3.4 bar)						
E2	Visual/Electrical Auto Reset	28 VDC 28 VAC MAX	<table border="1" style="display: inline-table; vertical-align: middle;"> <tr><td>1</td><td>C</td></tr> <tr><td>2</td><td>NC</td></tr> <tr><td>3</td><td>NO</td></tr> </table>	1	C	2	NC	3	NO	931153 (1.7 bar)
				1	C					
2	NC									
3	NO									
				929599 (3.4 bar)						

Note: For full indicator specifications see Section 6.

PRESSURE DROP CURVES

To select the correct housing and element it is recommended that the ratio between the bypass setting and the pressure drop across the filter with a clean element should be at least 3:1. All filters were tested in accordance with ISO 3968. "Determination of pressure drop flow characteristics of hydraulic fluid power filters", using mineral oil fluid SAE 10 at 32 cSt viscosity.

15CN-1 Elements

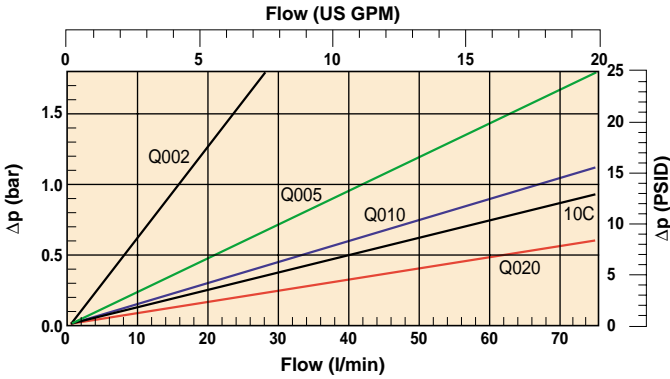

15CN-1 Empty Housing

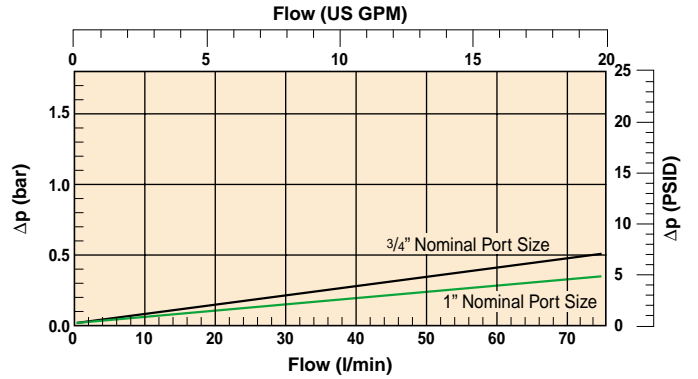

15CN-2 Elements

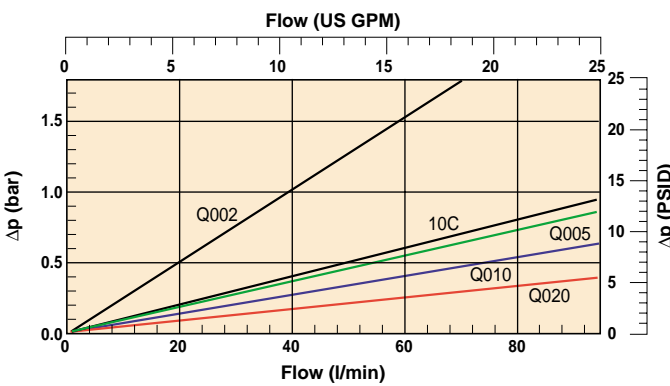

15CN-2 Empty Housing

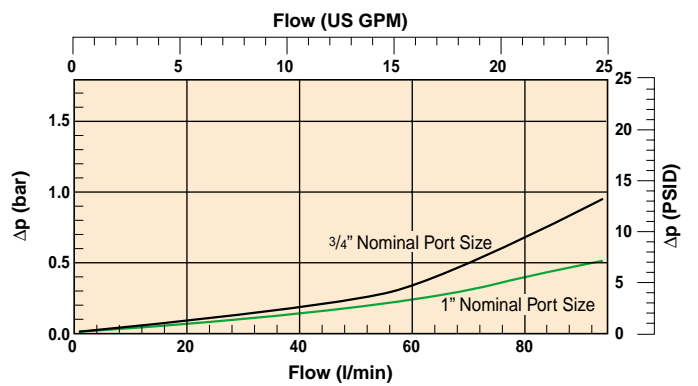

Medium Pressure Filters

15/40/80CN Series

40CN-1 Elements

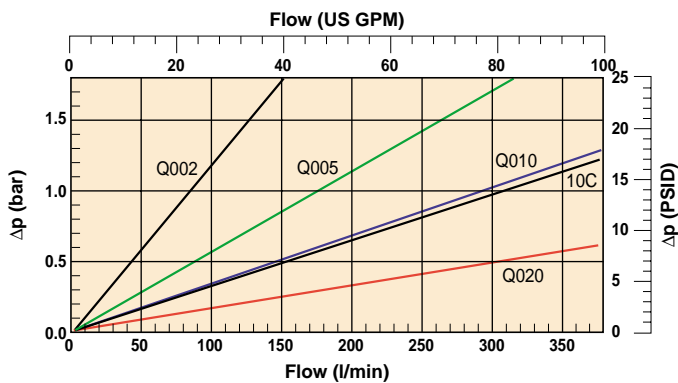

40CN-1 Empty Housing

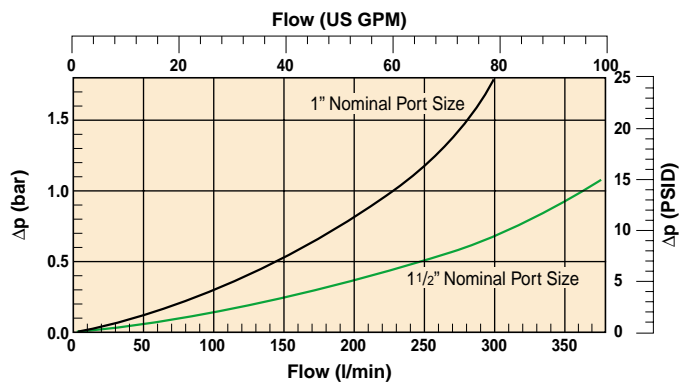

40CN-2 Elements

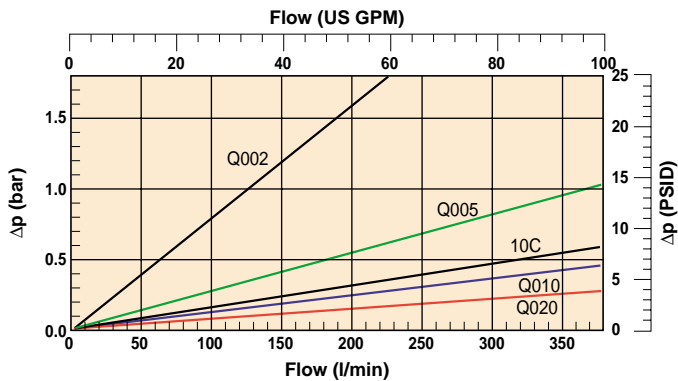

40CN-2 Empty Housing

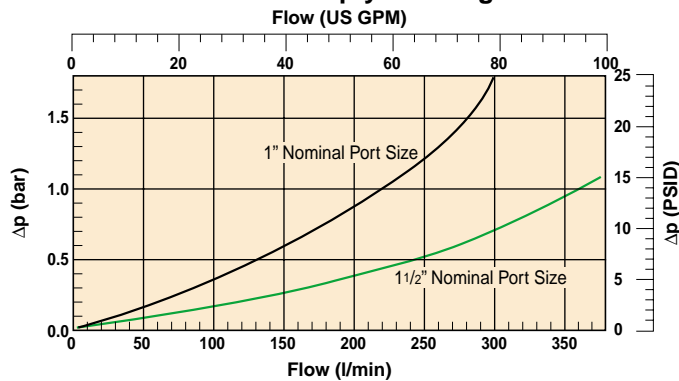

80CN-1 Elements

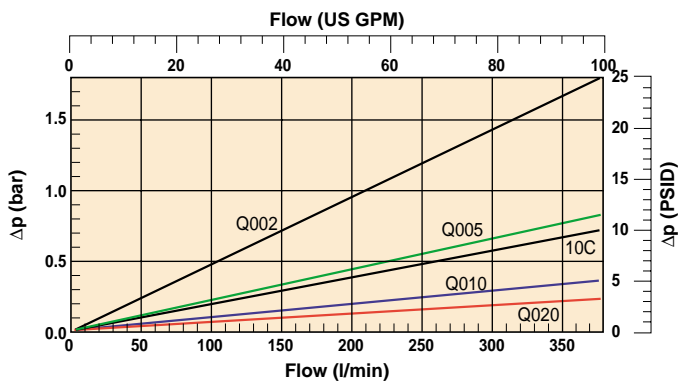

80CN-1 Empty Housing

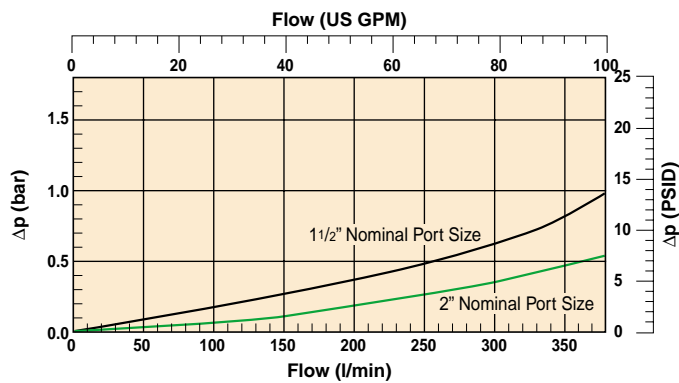

80CN-2 Elements

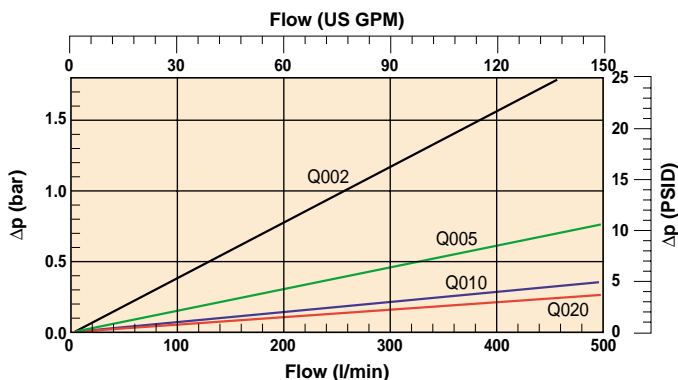

80CN-2 Empty Housing

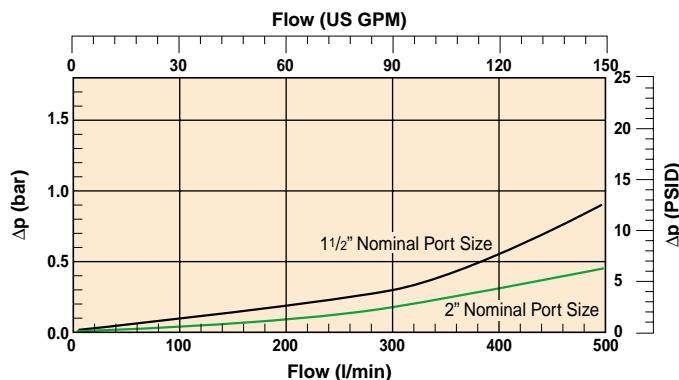

Note: All above data is calculated at 30cSt Rel density 0.856.

Element Service

- A. Stop the system's power unit.
- B. Relieve any system pressure in the filter line.
- C. Drain the filter bowl if drain port option is provided.
- D. Loosen and remove bowl.
- E. Remove element by pulling downward with a slight twisting motion and discard.
- F. Check bowl o-ring and anti-extrusion ring for damage and replace if necessary.
- G. Lubricate element o-ring with system fluid and place on post in filter head.
- H. Install bowl by rotating counter clockwise and tighten to specified torque.
 - 15CN — 15-20ft. lbs (20-27 Nm)
 - 40CN — 42-50ft. lbs (57-68 Nm)
 - 80CN — 60-70ft. lbs (80-95 Nm)
- I. Confirm there are no leaks after powering the system.

CN Filters Parts List

Index	Description
1	Head Options (Consult Factory)
2	Indicators M2-Visual Auto Reset; 1.7 bar M2-Visual Auto Reset; 3.5 bar
3	E2-Electrical/Visual; 1.7 bar c/w DIN 43650 Connector E2-Electrical/Visual; 3.5 bar c/w DIN 43650 Connector
4	Bypass Valve 1.7 bar assembly 3.5 bar assembly
5	Element (See Model Code Page)
6	Bowl Single Length With Drain Single Length Without Drain Double Length With Drain Double Length Without Drain
7	Bowl and Dust Seal Nitrile (Buna N) Fluoroelastomer
8	Drain Plug; SAE-4 Nitrile (Buna N) Fluoroelastomer

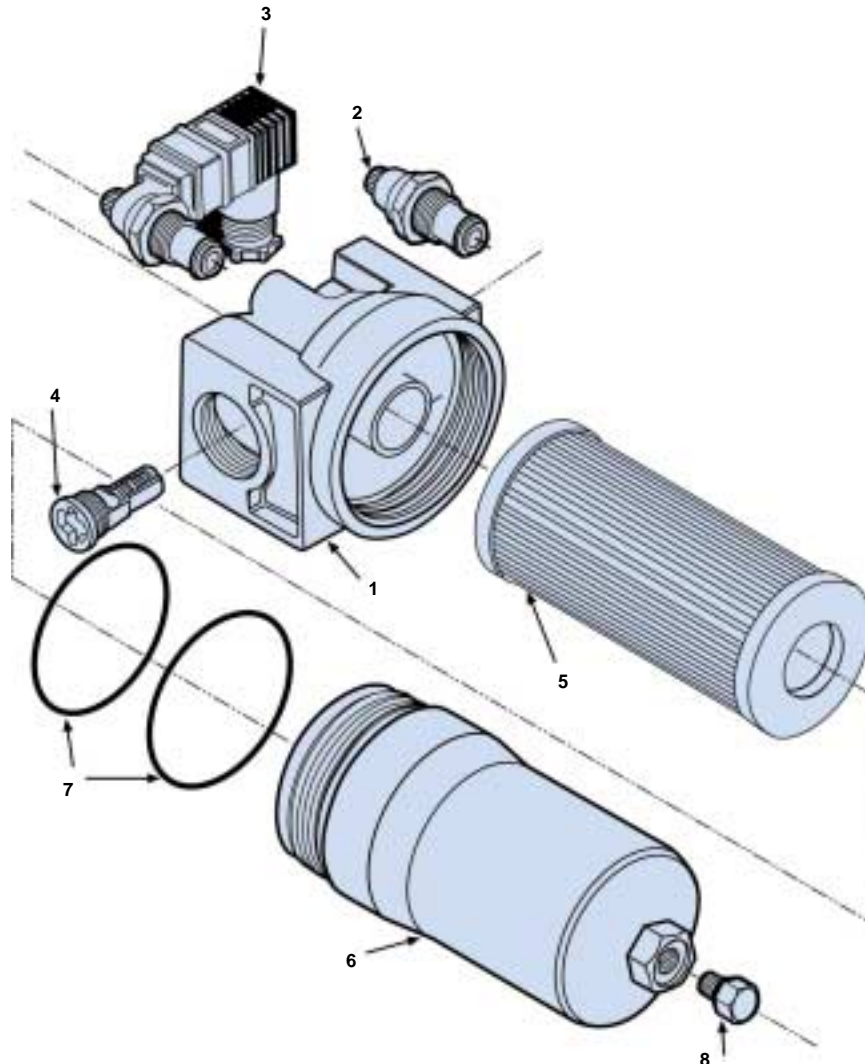

Medium Pressure Filters

15/40/80CN Series

PREFERRED PRODUCTS TABLE

The following standard filters are supplied with 3.4 bar bypass and Nitrile seals.					
Part Number	Part Number	Flow (l/min)	Media Rating	Ports	Replacement Elements
15CN-1-02Q-M2-50-C2C2-1	15CN-1-02Q-E2-50-C2C2-1	10	Q002	G 1	928935Q
15CN-1-05Q-M2-50-C2C2-1	15CN-1-05Q-E2-50-C2C2-1	35	Q005	G 1	G04041Q
15CN-1-10Q-M2-50-C2C2-1	15CN-1-10Q-E2-50-C2C2-1	60	Q010	G 1	928934Q
15CN-1-20Q-M2-50-C2C2-1	15CN-1-20Q-E2-50-C2C2-1	80	Q020	G 1	930367Q
15CN-2-02Q-M2-50-C2C2-1	15CN-2-02Q-E2-50-C2C2-1	25	Q002	G 1	928953Q
15CN-2-05Q-M2-50-C2C2-1	15CN-2-05Q-E2-50-C2C2-1	60	Q005	G 1	G04169Q
15CN-2-10Q-M2-50-C2C2-1	15CN-2-10Q-E2-50-C2C2-1	90	Q010	G 1	928952Q
15CN-2-20Q-M2-50-C2C2-1	15CN-2-20Q-E2-50-C2C2-1	110	Q020	G 1	930368Q
40CN-1-02Q-M2-50-E2E2-1	40CN-1-02Q-E2-50-E2E2-1	60	Q002	G 1½	926696Q
40CN-1-05Q-M2-50-E2E2-1	40CN-1-05Q-E2-50-E2E2-1	100	Q005	G 1½	G04048Q
40CN-1-10Q-M2-50-E2E2-1	40CN-1-10Q-E2-50-E2E2-1	180	Q010	G 1½	926835Q
40CN-1-20Q-M2-50-E2E2-1	40CN-1-20Q-E2-50-E2E2-1	260	Q020	G 1½	930099Q
40CN-2-02Q-M2-50-E2E2-1	40CN-2-02Q-E2-50-E2E2-1	80	Q002	G 1½	926697Q
40CN-2-05Q-M2-50-E2E2-1	40CN-2-05Q-E2-50-E2E2-1	200	Q005	G 1½	G04167Q
40CN-2-10Q-M2-50-E2E2-1	40CN-2-10Q-E2-50-E2E2-1	300	Q010	G 1½	926837Q
40CN-2-20Q-M2-50-E2E2-1	40CN-2-20Q-E2-50-E2E2-1	350	Q020	G 1½	930118Q
80CN-1-10Q-M2-50-F2F2-1	80CN-1-10Q-E2-50-F2F2-1	220	Q010	G 2	932658Q

Note: Filter assemblies ordered from the Part Number Matrix below are on extended lead times. Where possible, please make your selection from the table above.

PART NUMBER MATRIX

Table 1 F3	Table 2 40CN	Table 3 1	Table 4 10Q	Table 5 M2	Table 6 25	Table 7 E2E2	Table 8 1	Table 9 -
----------------------	------------------------	---------------------	-----------------------	----------------------	----------------------	------------------------	---------------------	---------------------

Table 1	Table 2	Table 3	Table 5																																																																																																								
<table border="1"> <thead> <tr><th colspan="2">Seals</th></tr> <tr><th>Description</th><th>SYMBOL</th></tr> </thead> <tbody> <tr><td>Nitrile</td><td>O</td></tr> <tr><td>Fluoroelastomer*</td><td>F3</td></tr> </tbody> </table>	Seals		Description	SYMBOL	Nitrile	O	Fluoroelastomer*	F3	<table border="1"> <thead> <tr><th colspan="2">Model Number</th></tr> <tr><th>Symbol</th><th></th></tr> </thead> <tbody> <tr><td>15CN</td><td></td></tr> <tr><td>40CN</td><td></td></tr> <tr><td>80CN</td><td></td></tr> </tbody> </table>	Model Number		Symbol		15CN		40CN		80CN		<table border="1"> <thead> <tr><th colspan="2">Housing Length</th></tr> <tr><th>Description</th><th>SYMBOL</th></tr> </thead> <tbody> <tr><td>Single Length</td><td>1</td></tr> <tr><td>Double Length</td><td>2</td></tr> </tbody> </table>	Housing Length		Description	SYMBOL	Single Length	1	Double Length	2	<table border="1"> <thead> <tr><th colspan="2">Indicator</th></tr> <tr><th>Description</th><th>SYMBOL</th></tr> </thead> <tbody> <tr><td>No Indicator (use with "11" option, no bypass only)</td><td>N</td></tr> <tr><td>No Indicator (use when model is equipped with bypass valve)</td><td>P</td></tr> <tr><td>Visual/Auto reset</td><td>M2</td></tr> <tr><td>FPC Visual/Auto reset</td><td>V3</td></tr> <tr><td>Electric Switch DIN 43650</td><td>E2</td></tr> <tr><td>FPC Electric DIN 43650</td><td>TW3</td></tr> <tr><td>FPC Electronic L.E.D.</td><td>FW3</td></tr> </tbody> </table>	Indicator		Description	SYMBOL	No Indicator (use with "11" option, no bypass only)	N	No Indicator (use when model is equipped with bypass valve)	P	Visual/Auto reset	M2	FPC Visual/Auto reset	V3	Electric Switch DIN 43650	E2	FPC Electric DIN 43650	TW3	FPC Electronic L.E.D.	FW3																																																												
Seals																																																																																																											
Description	SYMBOL																																																																																																										
Nitrile	O																																																																																																										
Fluoroelastomer*	F3																																																																																																										
Model Number																																																																																																											
Symbol																																																																																																											
15CN																																																																																																											
40CN																																																																																																											
80CN																																																																																																											
Housing Length																																																																																																											
Description	SYMBOL																																																																																																										
Single Length	1																																																																																																										
Double Length	2																																																																																																										
Indicator																																																																																																											
Description	SYMBOL																																																																																																										
No Indicator (use with "11" option, no bypass only)	N																																																																																																										
No Indicator (use when model is equipped with bypass valve)	P																																																																																																										
Visual/Auto reset	M2																																																																																																										
FPC Visual/Auto reset	V3																																																																																																										
Electric Switch DIN 43650	E2																																																																																																										
FPC Electric DIN 43650	TW3																																																																																																										
FPC Electronic L.E.D.	FW3																																																																																																										
<table border="1"> <thead> <tr><th colspan="5">Degree of Filtration</th></tr> <tr><th colspan="5">Average filtration ratio β (ISO 16889) / particle size μm(c)</th></tr> <tr><th>2</th><th>10</th><th>75</th><th>100</th><th>200</th><th>1000</th><th>CODE</th></tr> </thead> <tbody> <tr><td>N/A</td><td>N/A</td><td>N/A</td><td>N/A</td><td>N/A</td><td>4.5</td><td>02Q</td></tr> <tr><td>N/A</td><td>N/A</td><td>4.5</td><td>5</td><td>6</td><td>7</td><td>05Q</td></tr> <tr><td>N/A</td><td>6</td><td>8.5</td><td>9</td><td>10</td><td>12</td><td>10Q</td></tr> <tr><td>6</td><td>11</td><td>17</td><td>18</td><td>20</td><td>22</td><td>20Q</td></tr> <tr><td colspan="6">Water removal 40CN & 80CN only</td><td>WR</td></tr> </tbody> </table>	Degree of Filtration					Average filtration ratio β (ISO 16889) / particle size μm(c)					2	10	75	100	200	1000	CODE	N/A	N/A	N/A	N/A	N/A	4.5	02Q	N/A	N/A	4.5	5	6	7	05Q	N/A	6	8.5	9	10	12	10Q	6	11	17	18	20	22	20Q	Water removal 40CN & 80CN only						WR	<table border="1"> <thead> <tr><th colspan="2">Bypass Indicator Setting</th></tr> <tr><th>Description</th><th>SYMBOL</th></tr> </thead> <tbody> <tr><td>1.7 bar</td><td>25</td></tr> <tr><td>3.4 bar</td><td>50</td></tr> </tbody> </table> <p>If "No Bypass" option (11) & an indicator is selected, above symbols (25, 50) denote indicator settings.</p>	Bypass Indicator Setting		Description	SYMBOL	1.7 bar	25	3.4 bar	50	<table border="1"> <thead> <tr><th colspan="2">Design Number</th></tr> <tr><td colspan="2">Applied to the filter assembly by Parker Filtration.</td></tr> </thead> </table>	Design Number		Applied to the filter assembly by Parker Filtration.																																										
Degree of Filtration																																																																																																											
Average filtration ratio β (ISO 16889) / particle size μm(c)																																																																																																											
2	10	75	100	200	1000	CODE																																																																																																					
N/A	N/A	N/A	N/A	N/A	4.5	02Q																																																																																																					
N/A	N/A	4.5	5	6	7	05Q																																																																																																					
N/A	6	8.5	9	10	12	10Q																																																																																																					
6	11	17	18	20	22	20Q																																																																																																					
Water removal 40CN & 80CN only						WR																																																																																																					
Bypass Indicator Setting																																																																																																											
Description	SYMBOL																																																																																																										
1.7 bar	25																																																																																																										
3.4 bar	50																																																																																																										
Design Number																																																																																																											
Applied to the filter assembly by Parker Filtration.																																																																																																											
<table border="1"> <thead> <tr><th colspan="3">Ports</th></tr> <tr><th>Description</th><th>MODEL</th><th>SYMBOL</th></tr> </thead> <tbody> <tr><td>G½" Thread</td><td>15CN</td><td>B2B2</td></tr> <tr><td>G1</td><td></td><td>C2C2</td></tr> <tr><td>12, SAE Thread</td><td></td><td>M4M4</td></tr> <tr><td>16, SAE Thread</td><td></td><td>N4N4</td></tr> <tr><td>M27, ISO 6149</td><td></td><td>B3B3</td></tr> <tr><td>G1½</td><td>40CN</td><td>D2D2</td></tr> <tr><td>G1½</td><td></td><td>E2E2</td></tr> <tr><td>16, SAE Thread</td><td></td><td>N4N4</td></tr> <tr><td>24, SAE Thread</td><td></td><td>P4P4</td></tr> <tr><td>M33, ISO 6149</td><td></td><td>C3C3</td></tr> <tr><td>G1½</td><td>80CN</td><td>E2E2</td></tr> <tr><td>G2</td><td></td><td>F2F2</td></tr> <tr><td>24, SAE Thread</td><td></td><td>P4P4</td></tr> <tr><td>32, SAE Thread</td><td></td><td>R4R4</td></tr> <tr><td>2" 3000-M Flange Face</td><td></td><td>Y3Y3</td></tr> <tr><td>M42, ISO 6149</td><td></td><td>D3D3</td></tr> <tr><td>M48, ISO 6149</td><td></td><td>E3E3</td></tr> </tbody> </table>	Ports			Description	MODEL	SYMBOL	G½" Thread	15CN	B2B2	G1		C2C2	12, SAE Thread		M4M4	16, SAE Thread		N4N4	M27, ISO 6149		B3B3	G1½	40CN	D2D2	G1½		E2E2	16, SAE Thread		N4N4	24, SAE Thread		P4P4	M33, ISO 6149		C3C3	G1½	80CN	E2E2	G2		F2F2	24, SAE Thread		P4P4	32, SAE Thread		R4R4	2" 3000-M Flange Face		Y3Y3	M42, ISO 6149		D3D3	M48, ISO 6149		E3E3	<table border="1"> <thead> <tr><th colspan="2">Options</th></tr> <tr><th>Description</th><th>SYMBOL</th></tr> </thead> <tbody> <tr><td>None</td><td>1</td></tr> <tr><td>No Bypass</td><td>11</td></tr> <tr><td>Drain port on bowl</td><td>19</td></tr> <tr><td>No bypass and drain port</td><td>21</td></tr> </tbody> </table>	Options		Description	SYMBOL	None	1	No Bypass	11	Drain port on bowl	19	No bypass and drain port	21	<table border="1"> <thead> <tr><th colspan="3">Seal Kits</th></tr> <tr><th>MODEL</th><th>Nitrile (O)</th><th>Fluoroelastomer* (F3)</th></tr> </thead> <tbody> <tr><td>15CN</td><td>S02594</td><td>S02595</td></tr> <tr><td>40CN</td><td>S02596</td><td>S02597</td></tr> <tr><td>80CN</td><td>S03543</td><td>S03544</td></tr> </tbody> </table>	Seal Kits			MODEL	Nitrile (O)	Fluoroelastomer* (F3)	15CN	S02594	S02595	40CN	S02596	S02597	80CN	S03543	S03544																					
Ports																																																																																																											
Description	MODEL	SYMBOL																																																																																																									
G½" Thread	15CN	B2B2																																																																																																									
G1		C2C2																																																																																																									
12, SAE Thread		M4M4																																																																																																									
16, SAE Thread		N4N4																																																																																																									
M27, ISO 6149		B3B3																																																																																																									
G1½	40CN	D2D2																																																																																																									
G1½		E2E2																																																																																																									
16, SAE Thread		N4N4																																																																																																									
24, SAE Thread		P4P4																																																																																																									
M33, ISO 6149		C3C3																																																																																																									
G1½	80CN	E2E2																																																																																																									
G2		F2F2																																																																																																									
24, SAE Thread		P4P4																																																																																																									
32, SAE Thread		R4R4																																																																																																									
2" 3000-M Flange Face		Y3Y3																																																																																																									
M42, ISO 6149		D3D3																																																																																																									
M48, ISO 6149		E3E3																																																																																																									
Options																																																																																																											
Description	SYMBOL																																																																																																										
None	1																																																																																																										
No Bypass	11																																																																																																										
Drain port on bowl	19																																																																																																										
No bypass and drain port	21																																																																																																										
Seal Kits																																																																																																											
MODEL	Nitrile (O)	Fluoroelastomer* (F3)																																																																																																									
15CN	S02594	S02595																																																																																																									
40CN	S02596	S02597																																																																																																									
80CN	S03543	S03544																																																																																																									
Replacement Element Part Numbers																																																																																																											
<table border="1"> <thead> <tr><th colspan="6">Nitrile Seals</th></tr> <tr><th>MODEL</th><th>Q002</th><th>Q005</th><th>Q010</th><th>Q020</th><th>10C</th></tr> </thead> <tbody> <tr><td>15CN-1</td><td>928935Q</td><td>G04041Q</td><td>928934Q</td><td>930367Q</td><td>928932</td></tr> <tr><td>15CN-2</td><td>928953Q</td><td>G04169Q</td><td>928952Q</td><td>930368Q</td><td>928950</td></tr> <tr><td>40CN-1</td><td>926696Q</td><td>G04048Q</td><td>926835Q</td><td>930099Q</td><td>930095</td></tr> <tr><td>40CN-2</td><td>926697Q</td><td>G04167Q</td><td>926837Q</td><td>930118Q</td><td>930114</td></tr> <tr><td>80CN-1</td><td>932656Q</td><td>932657Q</td><td>932658Q</td><td>929899Q</td><td>929909</td></tr> <tr><td>80CN-2</td><td>932662Q</td><td>932663Q</td><td>932664Q</td><td>929923Q</td><td>929933</td></tr> </tbody> </table>						Nitrile Seals						MODEL	Q002	Q005	Q010	Q020	10C	15CN-1	928935Q	G04041Q	928934Q	930367Q	928932	15CN-2	928953Q	G04169Q	928952Q	930368Q	928950	40CN-1	926696Q	G04048Q	926835Q	930099Q	930095	40CN-2	926697Q	G04167Q	926837Q	930118Q	930114	80CN-1	932656Q	932657Q	932658Q	929899Q	929909	80CN-2	932662Q	932663Q	932664Q	929923Q	929933	<table border="1"> <thead> <tr><th colspan="6">Fluoroelastomer Seals</th></tr> <tr><th>MODEL</th><th>Q002</th><th>Q005</th><th>Q010</th><th>Q020</th><th>10C</th></tr> </thead> <tbody> <tr><td>15CN-1</td><td>932610Q</td><td>G04189Q</td><td>932612Q</td><td>930369Q</td><td>925385</td></tr> <tr><td>15CN-2</td><td>932616Q</td><td>G04190Q</td><td>932618Q</td><td>930370Q</td><td>925394</td></tr> <tr><td>40CN-1</td><td>926716Q</td><td>G04191Q</td><td>926836Q</td><td>930100Q</td><td>930096</td></tr> <tr><td>40CN-2</td><td>926717Q</td><td>G04192Q</td><td>926838Q</td><td>930119Q</td><td>930115</td></tr> <tr><td>80CN-1</td><td>932659Q</td><td>932660Q</td><td>932661Q</td><td>929903Q</td><td>929912</td></tr> <tr><td>80CN-2</td><td>932665Q</td><td>932666Q</td><td>932667Q</td><td>929927Q</td><td>929936</td></tr> </tbody> </table>						Fluoroelastomer Seals						MODEL	Q002	Q005	Q010	Q020	10C	15CN-1	932610Q	G04189Q	932612Q	930369Q	925385	15CN-2	932616Q	G04190Q	932618Q	930370Q	925394	40CN-1	926716Q	G04191Q	926836Q	930100Q	930096	40CN-2	926717Q	G04192Q	926838Q	930119Q	930115	80CN-1	932659Q	932660Q	932661Q	929903Q	929912	80CN-2	932665Q	932666Q	932667Q	929927Q	929936
Nitrile Seals																																																																																																											
MODEL	Q002	Q005	Q010	Q020	10C																																																																																																						
15CN-1	928935Q	G04041Q	928934Q	930367Q	928932																																																																																																						
15CN-2	928953Q	G04169Q	928952Q	930368Q	928950																																																																																																						
40CN-1	926696Q	G04048Q	926835Q	930099Q	930095																																																																																																						
40CN-2	926697Q	G04167Q	926837Q	930118Q	930114																																																																																																						
80CN-1	932656Q	932657Q	932658Q	929899Q	929909																																																																																																						
80CN-2	932662Q	932663Q	932664Q	929923Q	929933																																																																																																						
Fluoroelastomer Seals																																																																																																											
MODEL	Q002	Q005	Q010	Q020	10C																																																																																																						
15CN-1	932610Q	G04189Q	932612Q	930369Q	925385																																																																																																						
15CN-2	932616Q	G04190Q	932618Q	930370Q	925394																																																																																																						
40CN-1	926716Q	G04191Q	926836Q	930100Q	930096																																																																																																						
40CN-2	926717Q	G04192Q	926838Q	930119Q	930115																																																																																																						
80CN-1	932659Q	932660Q	932661Q	929903Q	929912																																																																																																						
80CN-2	932665Q	932666Q	932667Q	929927Q	929936																																																																																																						

* Fluoroelastomers are available under various registered trademarks, including Viton (a registered trademark of DuPont) and Fluorel (a registered trademark of 3M)