

SuperSOT

SOT23 NPN SILICON POWER (SWITCHING) TRANSISTORS

ISSUE 3 - NOVEMBER 1995

FMMT617 FMMT618
FMMT619 FMMT624
FMMT625

FEATURES

- * **625mW POWER DISSIPATION**
- * I_C CONT 3A
- * 12A Peak Pulse Current
- * Excellent H_{FE} Characteristics Up To 12A (pulsed)
- * Extremely Low Saturation Voltage E.g. 8mV Typ.
- * Extremely Low Equivalent On Resistance; $R_{CE(sat)}$

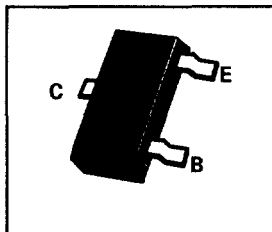

DEVICE TYPE	COMPLEMENT	PARTMARKING	$R_{CE(sat)}$
FMMT617	FMMT717	617	50mΩ at 3A
FMMT618	FMMT718	618	50mΩ at 2A
FMMT619	FMMT720	619	75mΩ at 2A
FMMT624	FMMT723	624	-
FMMT625	-	625	-

ABSOLUTE MAXIMUM RATINGS.

PARAMETER	SYMBOL	FMMT 617	FMMT 618	FMMT 619	FMMT 624	FMMT 625	UNIT
Collector-Base Voltage	V_{CBO}	15	20	50	125	150	V
Collector-Emitter Voltage	V_{CEO}	15	20	50	125	150	V
Emitter-Base Voltage	V_{EBO}	5	5	5	5	5	V
Peak Pulse Current**	I_{CP}	12	6	6	3	3	A
Continuous Collector Current	I_C	3	2.5	2	1	1	A
Base Current	I_B	500					mA
Power Dissipation at $T_{amb}=25^\circ\text{C}$*	P_{tot}	625					mW
Operating and Storage Temperature Range	$T_{j(stg)}$	-55 to +150					$^\circ\text{C}$

* Maximum power dissipation is calculated assuming that the device is mounted on a ceramic substrate measuring 15x15x0.6mm

**Measured under pulsed conditions. Pulse width=300μs. Duty cycle ≤ 2%
Spice parameter data is available upon request for these devices

FMMT617

ELECTRICAL CHARACTERISTICS (at $T_{amb} = 25^{\circ}\text{C}$ unless otherwise stated).

PARAMETER	SYMBOL	MIN.	TYP.	MAX.	UNIT	CONDITIONS.
Collector-Base Breakdown Voltage	$V_{(BR)CBO}$	15	70		V	$I_C=100\mu\text{A}$
Collector-Emitter Breakdown Voltage	$V_{(BR)CEO}$	15	18		V	$I_C=10\text{mA}^*$
Emitter-Base Breakdown Voltage	$V_{(BR)EBO}$	5	8.2		V	$I_E=100\mu\text{A}$
Collector Cut-Off Current	I_{CBO}			100	nA	$V_{CB}=10\text{V}$
Emitter Cut-Off Current	I_{EBO}			100	nA	$V_{EB}=4\text{V}$
Collector Emitter Cut-Off Current	I_{CES}			100	nA	$V_{CES}=10\text{V}$
Collector-Emitter Saturation Voltage	$V_{CE(sat)}$		8 70 150	14 100 200	mV mV mV	$I_C=0.1\text{A}, I_B=10\text{mA}^*$ $I_C=1\text{A}, I_B=10\text{mA}^*$ $I_C=3\text{A}, I_B=50\text{mA}^*$
Base-Emitter Saturation Voltage	$V_{BE(sat)}$		0.9	1.0	V	$I_C=3\text{A}, I_B=50\text{mA}^*$
Base-Emitter Turn-On Voltage	$V_{BE(on)}$		0.84	1.0	V	$I_C=3\text{A}, V_{CE}=2\text{V}^*$
Static Forward Current Transfer Ratio	h_{FE}	200 300 200 150	415 450 320 240 80			$I_C=10\text{mA}, V_{CE}=2\text{V}^*$ $I_C=200\text{mA}, V_{CE}=2\text{V}^*$ $I_C=3\text{A}, V_{CE}=2\text{V}^*$ $I_C=5\text{A}, V_{CE}=2\text{V}^*$ $I_C=12\text{A}, V_{CE}=2\text{V}^*$
Transition Frequency	f_T	80	120		MHz	$I_C=50\text{mA}, V_{CE}=10\text{V}$ $f=50\text{MHz}$
Output Capacitance	C_{obo}		30	40	pF	$V_{CB}=10\text{V}, f=1\text{MHz}$
Turn-On Time	$t_{(on)}$		120		ns	$V_{CC}=10\text{V}, I_C=3\text{A}$ $I_{B1}=I_{B2}=50\text{mA}$
Turn-Off Time	$t_{(off)}$		160		ns	

*Measured under pulsed conditions. Pulse width=300 μs . Duty cycle \leq 2%

TYPICAL CHARACTERISTICS

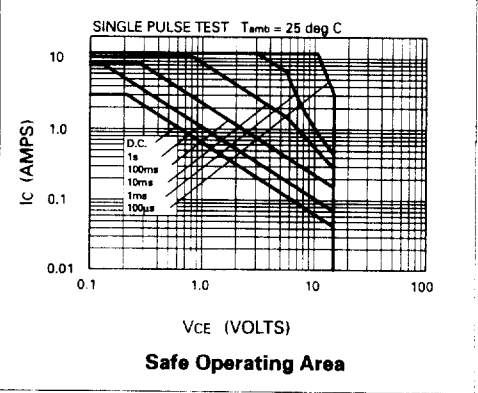
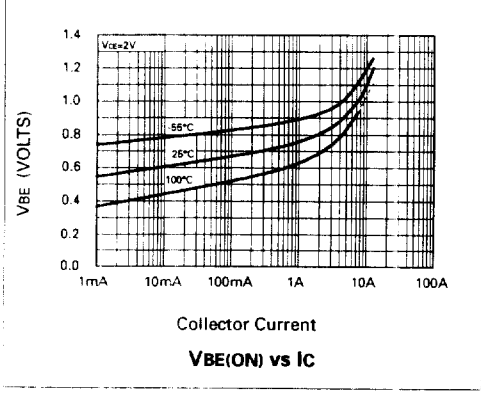
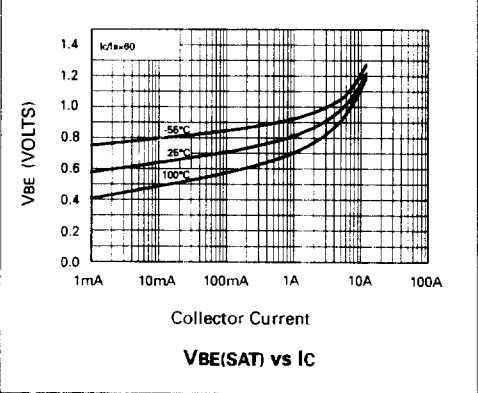
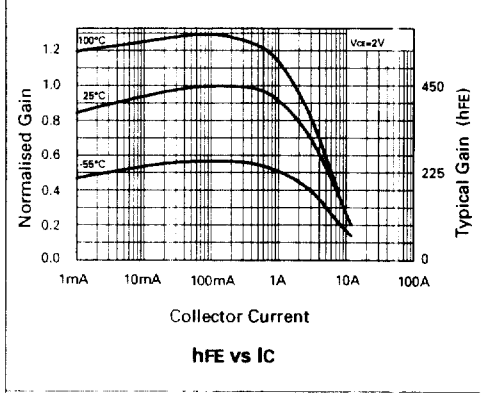
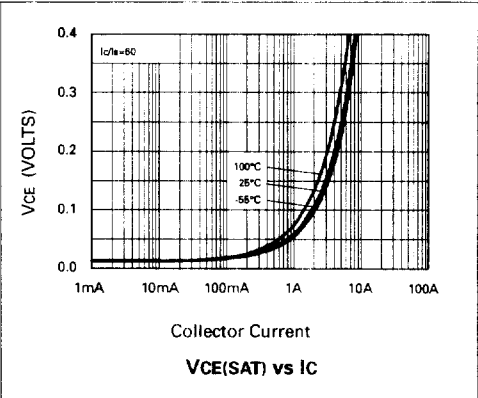
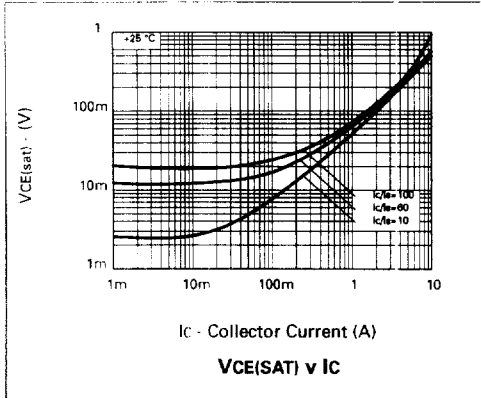

FM6T19

TYPICAL CHARACTERISTICS

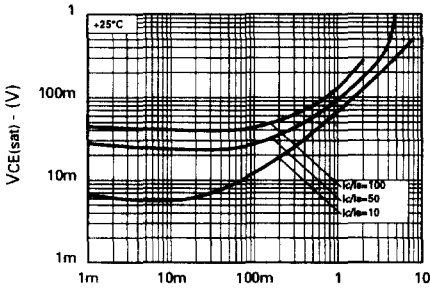

I_C - Collector Current (A)
 $V_{CE(sat)}$ v I_C

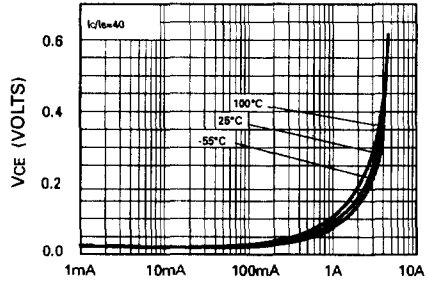

Collector Current
 $V_{CE(SAT)}$ vs I_C

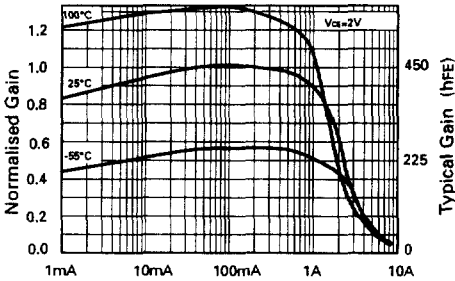

Collector Current
 h_{FE} vs I_C

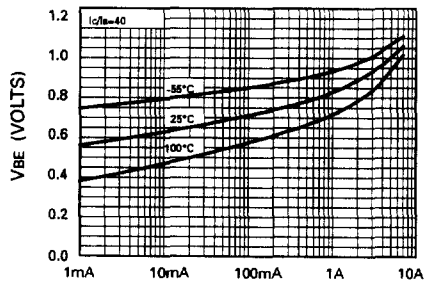

Collector Current
 $V_{BE(SAT)}$ vs I_C

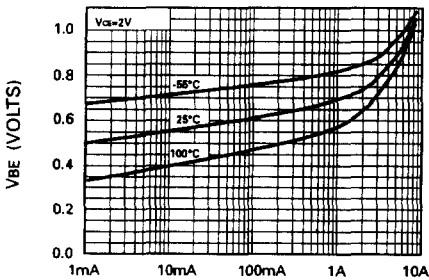

Collector Current
 $V_{BE(ON)}$ vs I_C

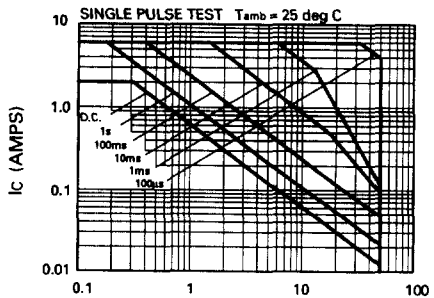

Safe Operating Area

PACKAGE OUTLINE DETAILS

SOT223

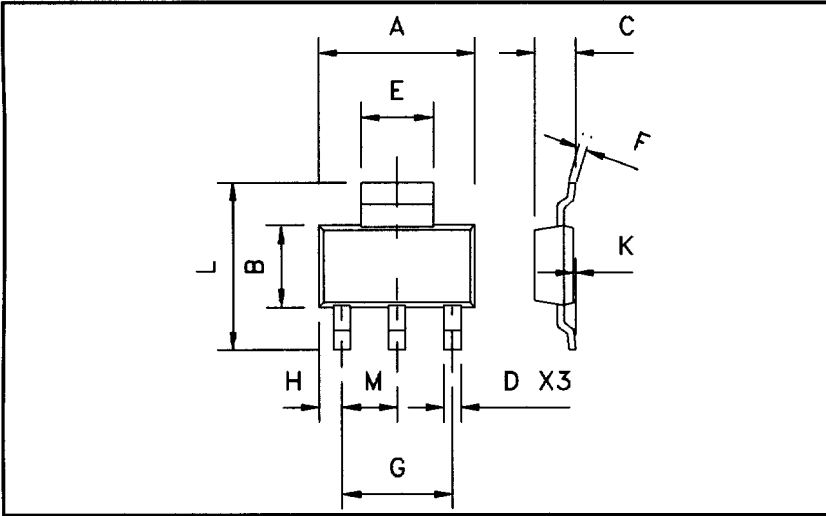

DIM	Millimeters		Inches	
	Min	Max	Min	Max
A	6.3	6.7	0.248	0.264
B	3.3	3.7	0.130	0.146
C	-	1.7	-	0.067
D	0.6	0.8	0.024	0.031
E	2.9	3.1	0.114	0.122
F	0.24	0.32	0.009	0.013
G	NOM 4.6		NOM 0.181	
H	0.85	1.05	0.033	0.041
K	0.02	0.10	0.0008	0.004
L	6.7	7.3	0.264	0.287
M	NOM 2.3		NOM 0.0905	

SOT89

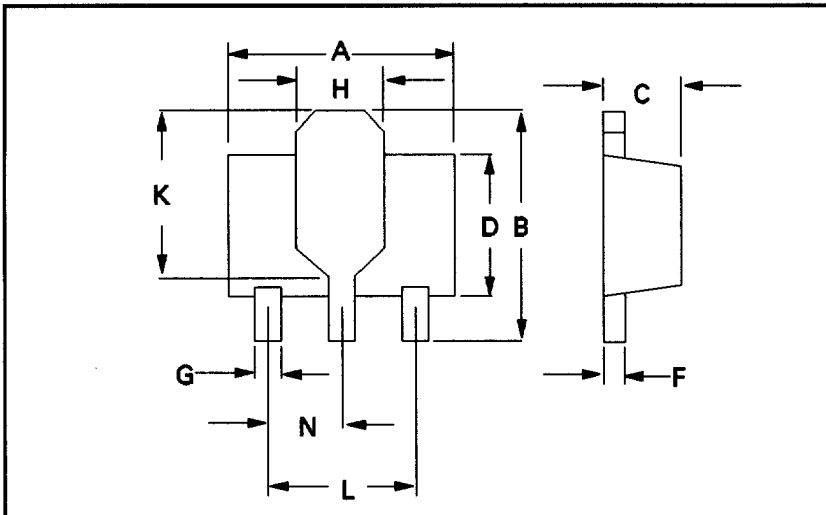

DIM	Millimeters		Inches	
	Min	Max	Min	Max
A	4.40	4.60	0.173	0.181
B	3.75	4.25	0.150	0.167
C	1.40	1.60	0.550	0.630
D	-	2.60	-	0.102
F	0.28	0.45	0.011	0.018
G	0.38	0.55	0.015	0.022
H	1.50	1.80	0.060	0.072
K	2.60	2.85	0.102	0.112
L	2.90	3.10	0.114	0.122
N	1.40	1.60	0.055	0.063

SOT23

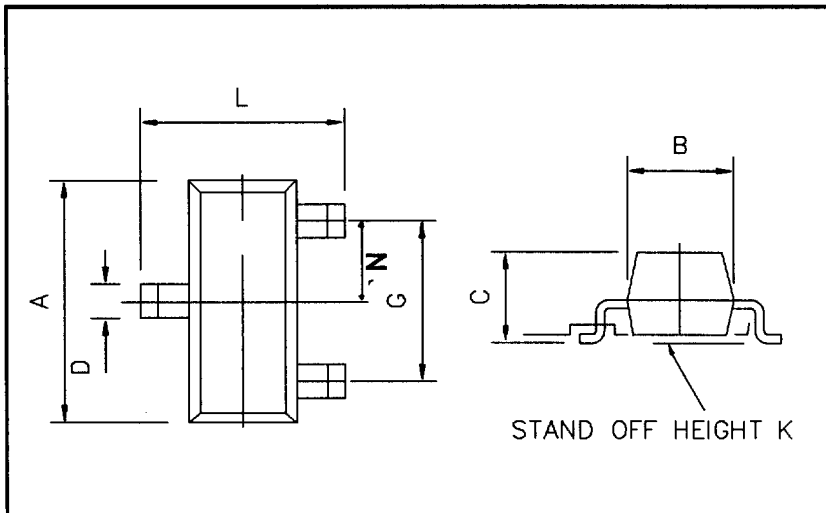

DIM	Millimeters		Inches	
	Min	Max	Min	Max
A	2.67	3.05	0.105	0.120
B	1.20	1.40	0.047	0.055
C	-	1.10	-	0.043
D	0.37	0.53	0.0145	0.021
F	0.085	0.15	0.0033	0.0059
G	NOM 1.9		NOM 0.075	
K	0.01	0.10	0.0004	0.004
L	2.10	2.50	0.0825	0.0985
N	NOM 0.95		NOM 0.37	

THERMAL RESISTANCE AND DERATING INFORMATION

D) SOT23 625 mW devices

θ_{j-c} = 100°C/W Typical
 θ_{j-a} = 190°C/W Typical
 = 200°C/W Maximum

Mounted on a 15 x 15 x 0.6 mm alumina substrate connected using 25mm x 0.5mm dia copper wire

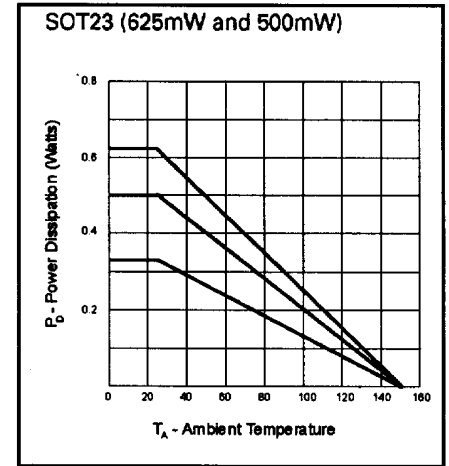
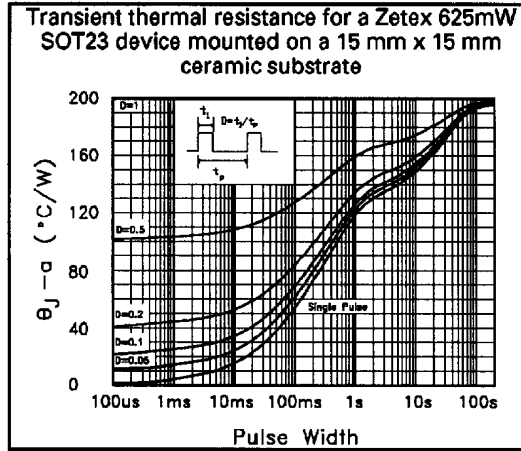

*330mW shown for reference only

E) SOT23 500 mW devices

θ_{j-c} = 110°C/W Typical
 θ_{j-a} = 200°C/W Typical
 = 250°C/W Maximum

Mounted on a 15 x 15 x 0.6 mm alumina substrate connected using 25mm x 0.5mm dia copper wire

