



Gated Cameo Development Kit Userguide

1. Product Overview

Thank you for purchasing the Gated Cameo Development Kit. The laser diode module in this kit emits a red spot or projection.

The Gated Cameo Development Kit is a unique, interchangeable, low cost, plug and play laser system designed primarily for aligning and positioning of garments, cloth, paper, wood and metal. The Gated Cameo Development Kit has user adjustable focus making it easy to focus over a wide range of distances and includes five interchangeable pattern optics. A swivel mounting clamp and a power supply is included in a rugged and attractive plastic carrying case designed to securely store all the kits components.

If you have any queries or require help when using the please call us on +44 (0)1495 212213 or contact your local representative.



2. Production Operation

Operating with a PS1:

The Gated Cameo Development Kit is supplied as standard with a 110V/240V to 3.5Volt PS1. The following items are included:

- Gated Cameo 635nm, 3mW, A Lens Laser
- x5 Interchangeable Optics
- 1 Meter JST to DC Cable
- Swivel Mounting Clamp M12
- 110V/240V to 3.5Volt PS1
- IEC to Euro mains power lead
- Euro to US Adaptor
- Euro to UK Adaptor (fitted to the IEC lead as standard)

1. Using the 1 Meter JST to DC Cable, plug the male DC jack end of the extension lead into the DC socket on the PS1, then plug the JST connector in to the Gated Cameo.
2. If you wish to use the power lead with a Euro socket simply unscrew the two screws in the front of the adaptor and open the lid. Remove the adaptor from the power lead.
3. If you wish to use the power lead in a US socket simply unscrews the two screws in the front of the adaptor and open the lid. Remove the adaptor from the power lead. Fit the plug in to the US adaptor, close the lid and tighten the screws.
4. Connect IEC plug to PS-1 power adaptor.
5. Plug the mains plug/adaptor into a mains socket.
6. Switch on at the mains socket.

Operating in CW Mode:

To operate laser in CW mode the Red, Black, Yellow and Blue leads should be connected to the following:

		1260 Gated Cameo
Pin 1	Red Lead	3.3Vdc to +5 Vdc
Pin 2	Black Lead	0 Vdc
Pin 3	Yellow Lead	+V Supply
Pin 4	Blue Lead	+V on,)v off

Should you require to use the Gating features of the Gated Cameo please refer to the Cameo Userguide (9090-02-034) or contact us directly for further assistance.

3. Focus Adjustment

The focus of the laser can be adjusted by using the supplied focus key. Should you need to adjust the focus please follow the instructions below:

1. Remove any interchangeable pattern optics, if fitted.
2. Insert focus key into laser barrel and align with focus control grooves.
3. Turn the focus key until desired focus is achieved.
4. Replace the interchangeable pattern optics if needed and rotate lens to achieve the desired projection.

4. Fan Angle & Working Distance

The size of the fan angle (or spread of the beam) will determine how long the line is. As an example when viewed from the same distance and at 90° angle to the surface a line with a fan angle of 33° will be longer than a line with a fan angle of 16°.

As a guide to the relationship between working distance, line length and fan angle please see the table below.

		Fan Angle (Degrees)				
		4.57	16	33	100	105
Distance From Object (mm)	250	20	70	148	596	652
	500	40	141	296	1192	1303
	750	60	211	444	1788	1995
	1000	80	281	592	2384	2606
	1250	100	351	741	2979	3258
	1500	120	422	889	3575	3910
	1750	140	492	1037	4171	4561
	2000	160	562	1185	4767	5213
	2250	180	632	1333	5363	5865
	2500	200	703	1481	5959	6516
	2750	219	773	1629	6555	7168
	3000	239	843	1777	7151	7819
	3250	259	914	1925	7746	8471
	3500	279	984	2073	8342	9123
	3750	299	1054	2222	8938	9774
	4000	319	1124	2370	9534	10426
	4250	339	1195	2518	10130	11077
4500	359	1265	2666	10726	11729	
4750	379	1335	2814	11322	12381	
5000	399	1405	2962	11918	13032	

Line Length (mm)

5. Changing The Optics

A set of 5 interchangeable pattern optics are supplied with the Gated Cameo Development Kit including:

4x4 Grid - 4.57° fan angle

Large Cross – 100° fan angle

L8 Line – 16° fan angle

Medium Line– 33° fan angle

Long Line – 105° fan angle

To change the pattern please follow the instructions below:

1. Remove any interchangeable pattern optics if fitted.
2. Replace the interchangeable pattern optics and rotate to achieve the desired projection.
3. Please ensure that any optics not fitted to the laser module is kept away from sources of dust etc.

6. Mounting

Mounting the Gated Cameo in the Swivel Mount

1. Un-tighten Allen screw A.
2. Slide the laser into the mounting hole and tighten Allen key A.
3. For vertical adjustment of the laser un-tighten Allen screw B. This will allow the section which mounts the laser to be adjusted. When the vertical positioning is complete retighten Allen screw B.
4. For horizontal adjustment of the laser un-tighten Allen screw C. This will allow the main body of the mount to be moved. When the horizontal positioning is complete retighten Allen screw C.
5. To secure the swivel mount to a surface screws, machine screw can be used in conjunction with the base section.

Please refer to diagram B for thread details.

7. Warranty & Repair

If your product develops a fault within 24 months from the date of purchase Global Laser will repair / replace the product. If you wish to return a faulty product contact your local representative or Global Laser to obtain a RMA (Return Material Authorisation code) and return to the address below:

Global Laser Ltd
Units 9-10
Roseheyworth Business Park
Abertillery
Gwent, NP13 1SP
United Kingdom

8. Safety & Classification

These modules are intended for incorporation into customer equipment. They are classified in accordance with IEC60825-1 2007, which should be consulted prior to designing or using any laser product. The following labels are supplied for attachment to the customer's equipment, but responsibility for compliance with the standard remains with the user.

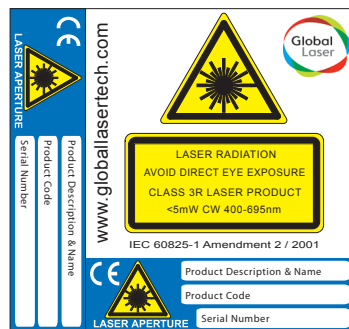

Class 3R Laser Label

IEC 60825 Warning Labels (examples)

9. Diagrams

A) Gated Cameo Laser Diode Module

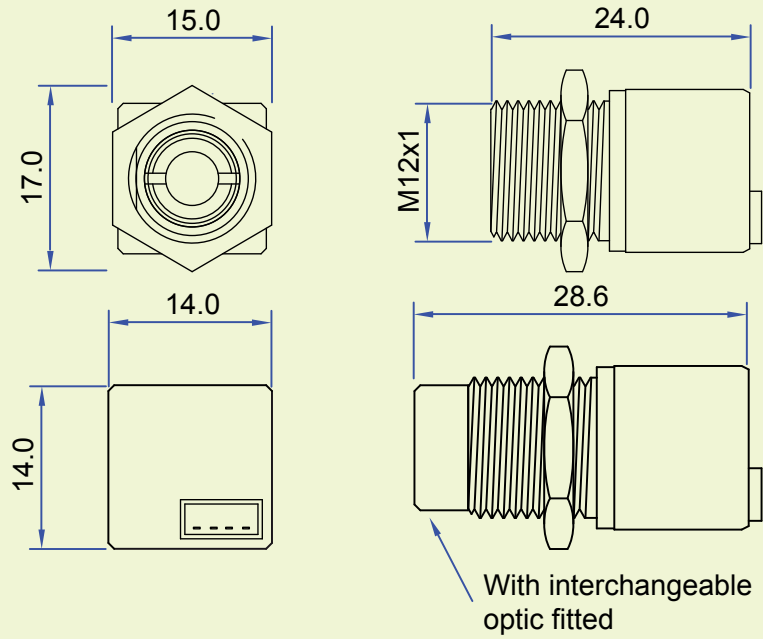

B) Heavy Duty Mounting Clamp

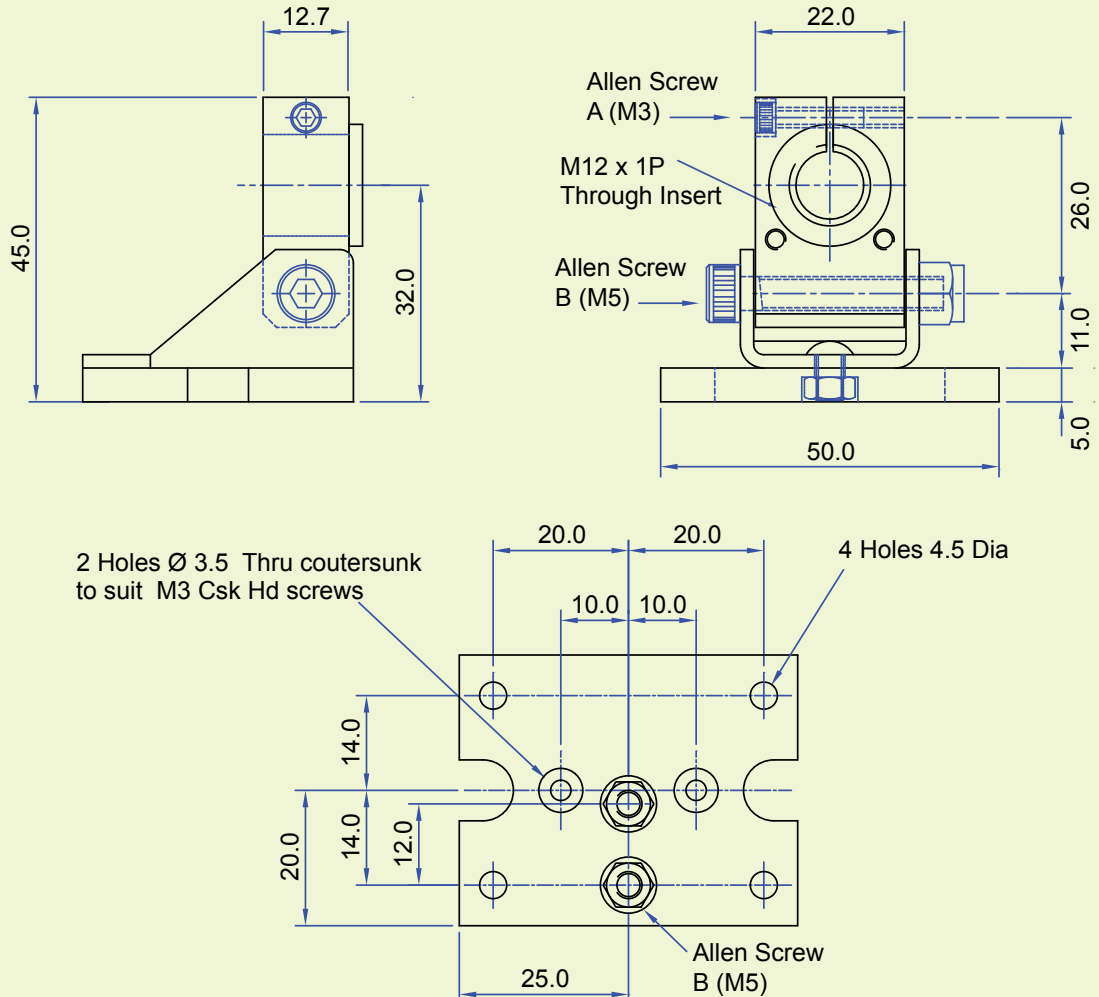

9. Diagrams

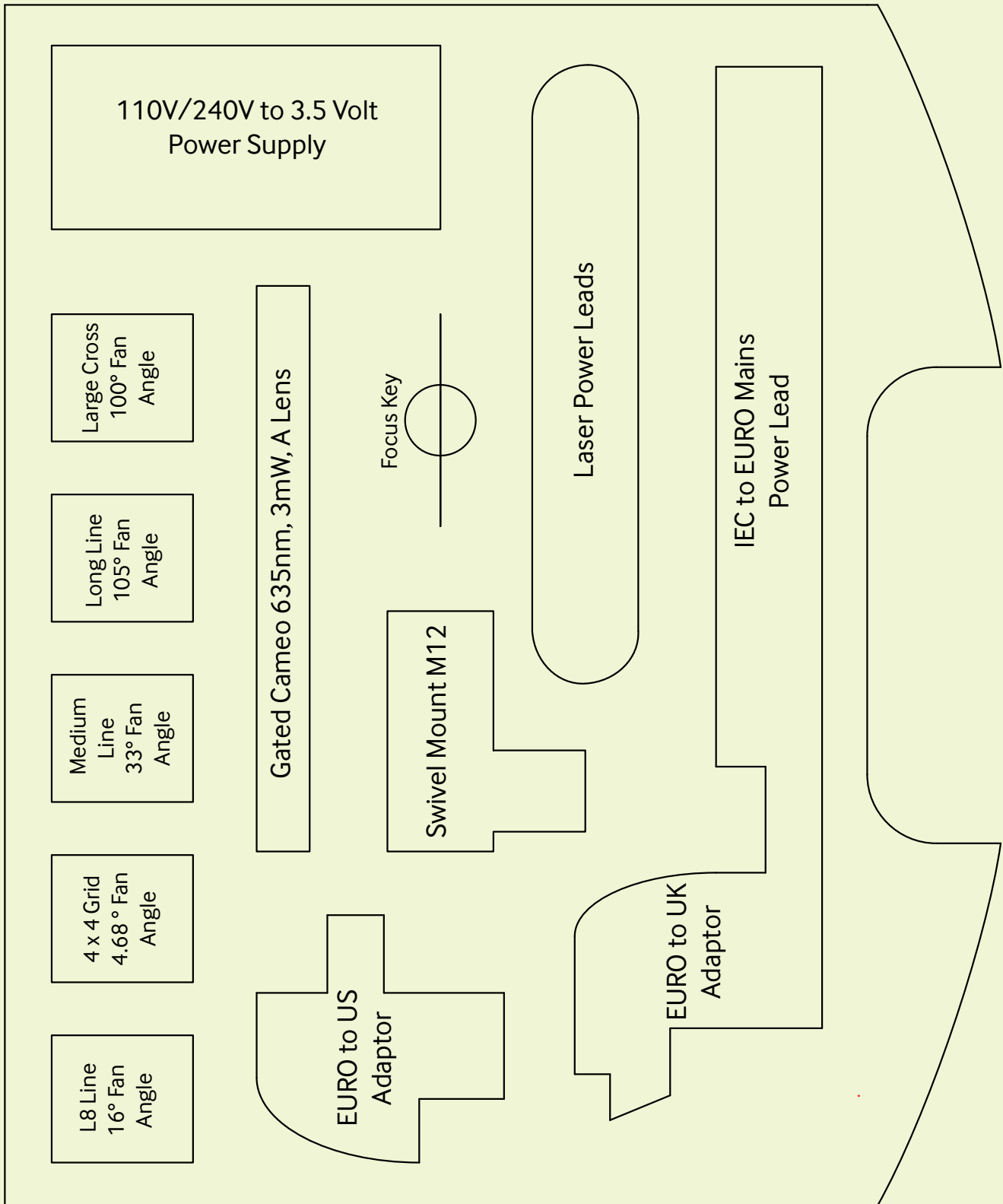

Notes.

Please Note: Global Laser reserve the right to change descriptions and specifications without notice.



9090-02-107 Rev 1 30/01/2017



T: +44 (0)1495 212213
F: +44 (0)1495 214004
E: sales@globallasertech.com
www.globallasertech.com

Global Laser Ltd
Units 9-10
Roseheyworth Business Park
Abertillery, Gwent NP13 1SP UK