

# HG277/HG2277/HG4277

## High Precision Operational Amplifiers

### Features

- Ultralow Offset Voltage: 10  $\mu$ V
- Ultralow Drift:  $\pm 0.1 \mu$ V/ $^{\circ}$ C
- High Open-Loop Gain: 134 dB
- High Common-Mode Rejection: 140 dB
- High Power Supply Rejection: 130 dB
- Low Bias Current: 1-nA maximum
- Wide Supply Range:  $\pm 2$  V to  $\pm 18$  V
- Low Quiescent Current: 800  $\mu$ A/amplifier
- Single, Dual, and Quad Versions

### Applications

- Transducer Amplifiers
- Bridge Amplifiers
- Temperature Measurements
- Strain Gage Amplifiers
- Precision Integrators
- Battery-Powered Instruments
- Test Equipment

### Description

The HGx277 series precision operational amplifiers replace the industry standard HG-177. They offer improved noise, wider output voltage swing, and are twice as fast with half the quiescent current. Features include ultralow offset voltage and drift, low bias current, high common-mode rejection, and high power supply rejection. Single, dual, and quad versions have identical specifications, for maximum design flexibility.

HGx277 series operational amplifiers operate from  $\pm 2$ -V to  $\pm 18$ -V supplies with excellent performance. Unlike most operational amplifiers which are specified at only one supply voltage, the HGx277 series is specified for real-world applications; a single limit applies over the  $\pm 5$ -V to  $\pm 15$ -V supply range. High performance is maintained as the amplifiers swing to their specified limits. Because the initial offset voltage ( $\pm 20 \mu$ V maximum) is so low, user adjustment is usually not required. However, the single version (HG277) provides external trim pins for special applications.

HG277 operational amplifiers are easy to use and free from phase inversion and the overload problems found in some other operational amplifiers. They are stable in unity gain and provide excellent dynamic behavior over a wide range of load conditions. Dual and quad versions feature completely independent circuitry for lowest crosstalk and freedom from interaction, even when overdriven or overloaded.

**0.1 Hz to 10 Hz Noise**

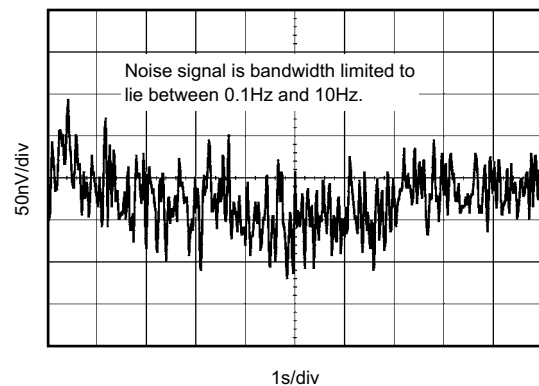

### ORDERING INFORMATION

DEVICE	Package Type	MARKING	Packing	Packing Qty
HG277N	DIP8L	HG277	TUBE	2000pcs/box
HG2277N	DIP8L	HG2277	TUBE	2000pcs/box
HG4277N	DIP14L	HG4277	TUBE	1000pcs/box
HG277M/TR	SOP8L	HG277	REEL	2500pcs/reel
HG2277M/TR	SOP8L	HG2277	REEL	2500pcs/reel
HG4277M/TR	SOP14L	HG4277	REEL	2500pcs/reel
HG277DQ/TR	DFN-8	HG277	REEL	3000pcs/reel
HG2277DQ/TR	DFN-8	HG2277	REEL	3000pcs/reel

**Pin Configuration and Functions**

**HG277 N and M Packages**  
8-Pin PDIP and SOIC  
Top View

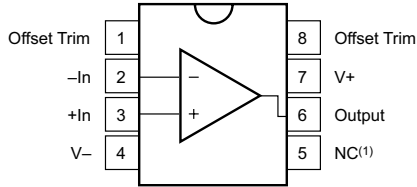

**HG277 DQ Package**  
8-Pin DFN  
Top View

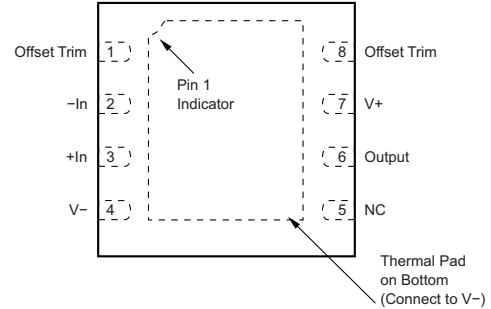

**Pin Functions: HG277**

PIN		I/O	DESCRIPTION
NO.	NAME		
1	Offset Trim	I	Input offset voltage trim (leave floating if not used)
2	-In	I	Inverting input
3	+In	I	Noninverting input
4	V-	—	Negative (lowest) power supply
5	NC	—	No internal connection (can be left floating)
6	Output	O	Output
7	V+	—	Positive (highest) power supply
8	Offset Trim	—	Input offset voltage trim (leave floating if not used)

**HG2277 N and M Packages**  
8-Pin PDIP and SOIC  
Top View

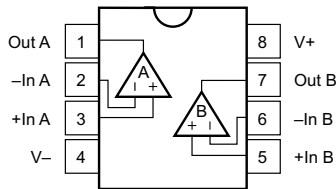

**HG2277 DQ Package**  
8-Pin DFN  
Top View

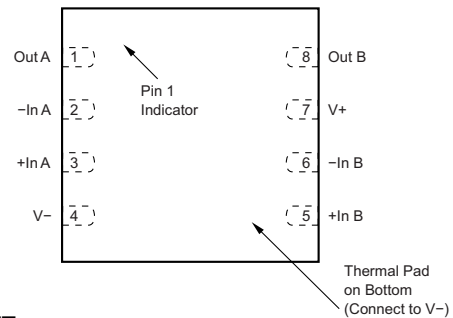

**Pin Functions: HG2277**

PIN			I/O	DESCRIPTION
NAME	PDIP, SOIC NO.	DFN NO.		
Out A	1	1	O	Output channel A
-In A	2	2	I	Inverting input channel A
+In A	3	3	I	Noninverting input channel A
V-	4	4	—	Negative (lowest) power supply
+In B	5	5	I	Noninverting input channel B
-In B	6	6	I	Inverting input channel B
Out B	7	8	O	Output channel B
V+	8	7	—	Positive (highest) power supply

**HG4277 N and M Packages  
14 Pins PDIP and SOIC  
Top View**

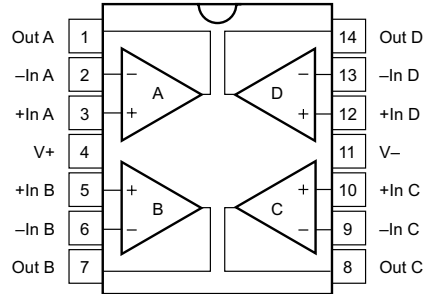

**Pin Functions: HG4277**

PIN		I/O	DESCRIPTION
NO.	NAME		
1	Out A	O	Output channel A
2	-In A	I	Inverting input channel A
3	+In A	I	Noninverting input channel A
4	V+	—	Positive (highest) power supply
5	+In B	I	Noninverting input channel B
6	-In B	I	Inverting input channel B
7	Out B	O	Output channel B
8	Out C	O	Output channel C
9	-In C	I	Inverting input channel C
10	+In C	I	Noninverting input channel C
11	V-	—	Negative (lowest) power supply
12	+In D	I	Noninverting input channel D
13	-In D	I	Inverting input channel D
14	Out D	O	Output channel D

## Specifications

### Absolute Maximum Ratings

over operating free-air temperature range (unless otherwise noted) <sup>(1)</sup>

	MIN	MAX	UNIT
Supply voltage, $V_s = (V+) - (V-)$		36	V
Input voltage	(V-) -0.7	(V+) +0.7	V
Output short-circuit <sup>(2)</sup>	Continuous		
Operating temperature	0	70	°C
Junction temperature		150	°C
Lead temperature		300	°C
Storage temperature, $T_{stg}$	0	70	°C

- (1) Stresses beyond those listed under *Absolute Maximum Ratings* may cause permanent damage to the device. These are stress ratings only, which do not imply functional operation of the device at these or any other conditions beyond those indicated under *Recommended Operating Conditions*. Exposure to absolute-maximum-rated conditions for extended periods may affect device reliability.
- (2) Short-circuit to ground, one amplifier per package.

### ESD Ratings

		VALUE	UNIT
$V_{(ESD)}$ Electrostatic discharge	Human-body model (HBM), per ANSI/ESDA/JEDEC JS-001 <sup>(1)</sup>	±2000	V
	Charged-device model (CDM), per JEDEC specification JESD22-C101 <sup>(2)</sup>	±500	

- (1) JEDEC document JEP155 states that 500-V HBM allows safe manufacturing with a standard ESD control process.
- (2) JEDEC document JEP157 states that 250-V CDM allows safe manufacturing with a standard ESD control process.

### Recommended Operating Conditions

over operating free-air temperature range (unless otherwise noted)

	MIN	NOM	MAX	UNIT
Supply voltage, $V_s = (V+) - (V-)$	4 (±2)	30 (±15)	36 (±18)	V
Specified temperature	0		+70	°C

### Thermal Information for HG277

THERMAL METRIC <sup>(1)</sup>	HG277			UNIT
	N (PDIP)	M (SOIC)	DQ (DFN)	
	8 PINS			
$R_{\theta JA}$ Junction-to-ambient thermal resistance	49.2	110.1	40.7	°C/W
$R_{\theta JC(top)}$ Junction-to-case (top) thermal resistance	39.4	52.2	41.3	°C/W
$R_{\theta JB}$ Junction-to-board thermal resistance	26.4	52.3	16.7	°C/W
$\Psi_{JT}$ Junction-to-top characterization parameter	15.4	10.4	0.6	°C/W
$\Psi_{JB}$ Junction-to-board characterization parameter	26.3	51.5	16.9	°C/W
$R_{\theta JC(bot)}$ Junction-to-case (bottom) thermal resistance	—	—	3.3	°C/W

- (1) For more information about traditional and new thermal metrics, see the *Semiconductor and IC Package Thermal Metrics* application report, [SPRA953](#).

### Thermal Information for HG2277

THERMAL METRIC <sup>(1)</sup>	HG2277			UNIT
	N (PDIP)	M (SOIC)	DQ (DFN)	
	8 PINS			
$R_{\theta JA}$ Junction-to-ambient thermal resistance	47.2	107.4	39.3	°C/W
$R_{\theta JC(top)}$ Junction-to-case (top) thermal resistance	36.0	45.8	36.9	°C/W

- (1) For more information about traditional and new thermal metrics, see the *Semiconductor and IC Package Thermal Metrics* application report, [SPRA953](#).

**Thermal Information for HG2277 (continued)**

THERMAL METRIC <sup>(1)</sup>		HG2277			UNIT
		N (PDIP)	M (SOIC)	DQ (DFN)	
		8 PINS			
R <sub>θJB</sub>	Junction-to-board thermal resistance	24.4	47.9	15.4	°C/W
ψ <sub>JT</sub>	Junction-to-top characterization parameter	13.4	5.7	0.4	°C/W
ψ <sub>JB</sub>	Junction-to-board characterization parameter	24.3	47.3	15.6	°C/W
R <sub>θJC(bot)</sub>	Junction-to-case (bottom) thermal resistance	—	—	2.2	°C/W

**Thermal Information for HG4277**

THERMAL METRIC <sup>(1)</sup>		HG4277		UNIT
		N (SOIC)	M (PDIP)	
		14 PINS		
R <sub>θJA</sub>	Junction-to-ambient thermal resistance	67.0	66.3	°C/W
R <sub>θJC(top)</sub>	Junction-to-case (top) thermal resistance	24.1	20.5	°C/W
R <sub>θJB</sub>	Junction-to-board thermal resistance	22.5	26.8	°C/W
ψ <sub>JT</sub>	Junction-to-top characterization parameter	2.2	2.1	°C/W
ψ <sub>JB</sub>	Junction-to-board characterization parameter	22.1	26.2	°C/W
R <sub>θJC(bot)</sub>	Junction-to-case (bottom) thermal resistance	—	—	°C/W

(1) For more information about traditional and new thermal metrics, see the *Semiconductor and IC Package Thermal Metrics* application report, [SPRA953](#).

**Electrical Characteristics for HGx277N, HGx277M, and HGx277x**

At T<sub>A</sub> = 25°C, and R<sub>L</sub> = 2 kΩ, unless otherwise noted

PARAMETER		TEST CONDITIONS	HG277N, M HG2277N, M			HG277x HG2277x HG4277x			UNIT
			MIN	TYP <sup>(1)</sup>	MAX	MIN	TYP <sup>(1)</sup>	MAX	
<b>OFFSET VOLTAGE</b>									
V <sub>OS</sub>	Input Offset Voltage			±10	±20		±20	±50	μV
	Input Offset Voltage Over Temperature	HG277N, M (high-grade, single)	T <sub>A</sub> = 0°C to 65°C		±30				μV
		HG2277N, M (high-grade, dual)			±50				
		All Versions					±100		
		AIDRM Versions							
dV <sub>OS</sub> /dT	Input Offset Voltage Drift	HG277N, M (high-grade, single)	T <sub>A</sub> = 0°C to 65°C	±0.1	±0.15				μV/°C
		HG2277N, M (high-grade, dual)		±0.1	±0.25				
		All AIDRM Versions				±0.15	±1		
	Input Offset Voltage: (all models)	vs Time		0.2			See <sup>(2)</sup>		μV/mo
		vs Power Supply (PSRR)	V <sub>S</sub> = ±2 V to ±18 V T <sub>A</sub> = 0°C to 65°C		±0.3	±0.5		See <sup>(2)</sup>	±1
	Channel Separation (dual, quad)	DC		0.1			See <sup>(2)</sup>		μV/V

(1) V<sub>S</sub> = ±15 V

(2) Specifications are the same as HG277N,M

**Electrical Characteristics for HGx277N, HGx277M, and HGx277x (continued)**

At  $T_A = 25^\circ\text{C}$ , and  $R_L = 2\text{ k}\Omega$ , unless otherwise noted

PARAMETER		TEST CONDITIONS	HG277N, M HG2277N, M			HG277x HG2277x HG4277x			UNIT
			MIN	TYP <sup>(1)</sup>	MAX	MIN	TYP <sup>(1)</sup>	MAX	
<b>INPUT BIAS CURRENT</b>									
$I_B$	Input Bias Current	$T_A = 0^\circ\text{C}$ to $65^\circ\text{C}$		$\pm 0.5$	$\pm 1$		See <sup>(2)</sup>	$\pm 2.8$	nA
								$\pm 4$	
$I_{OS}$	Input Offset Current	$T_A = 0^\circ\text{C}$ to $65^\circ\text{C}$		$\pm 0.5$	$\pm 1$		See <sup>(2)</sup>	$\pm 2.8$	nA
								$\pm 4$	
<b>NOISE</b>									
	Input Voltage Noise, $f = 0.1$ to $10\text{ Hz}$			0.22			See <sup>(2)</sup>		$\mu\text{V}_{PP}$
$e_n$	Input Voltage Noise Density			$f = 10\text{ Hz}$			See <sup>(2)</sup>		nV/ $\sqrt{\text{Hz}}$
				$f = 100\text{ Hz}$	12		See <sup>(2)</sup>		
				$f = 1\text{ kHz}$	8		See <sup>(2)</sup>		
				$f = 10\text{ kHz}$	8		See <sup>(2)</sup>		
$i_n$	Current Noise Density, $f = 1\text{ kHz}$			0.2			See <sup>(2)</sup>		pA/ $\sqrt{\text{Hz}}$
<b>INPUT VOLTAGE RANGE</b>									
$V_{CM}$	Common-Mode Voltage Range			(V <sup>-</sup> )+2	(V <sup>+</sup> )-2		See <sup>(2)</sup>	See <sup>(2)</sup>	V
CMRR	Common-Mode Rejection	$V_{CM} = (V^-) + 2\text{ V}$ to $(V^+) - 2\text{ V}$		130	140		115	See <sup>(2)</sup>	dB
		$T_A = 0^\circ\text{C}$ to $65^\circ\text{C}$		128			115		
<b>INPUT IMPEDANCE</b>									
	Differential			100    3			See <sup>(2)</sup>		M $\Omega$    pF
	Common-Mode	$V_{CM} = (V^-) + 2\text{ V}$ to $(V^+) - 2\text{ V}$		250    3			See <sup>(2)</sup>		G $\Omega$    pF
<b>OPEN-LOOP GAIN</b>									
$A_{OL}$	Open-Loop Voltage Gain	$V_O = (V^-) + 0.5\text{ V}$ to $(V^+) - 1.2\text{ V}$ , $R_L = 10\text{ k}\Omega$		140			See <sup>(2)</sup>		dB
		$V_O = (V^-) + 1.5\text{ V}$ to $(V^+) - 1.5\text{ V}$ , $R_L = 2\text{ k}\Omega$		126	134		See <sup>(2)</sup>	See <sup>(2)</sup>	
		$V_O = (V^-) + 1.5\text{ V}$ to $(V^+) - 1.5\text{ V}$ , $R_L = 2\text{ k}\Omega$		126			See <sup>(2)</sup>		dB
		$T_A = 0^\circ\text{C}$ to $65^\circ\text{C}$							
<b>FREQUENCY RESPONSE</b>									
GBW	Gain-Bandwidth Product			1			See <sup>(2)</sup>		MHz
SR	Slew Rate			0.8			See <sup>(2)</sup>		V/ $\mu\text{s}$
	Settling Time	0.1%	$V_S = \pm 15\text{ V}$ , $G = 1$ , 10-V Step	14			See <sup>(2)</sup>		$\mu\text{s}$
		0.01%		16		See <sup>(2)</sup>			
	Overload Recovery Time	$V_{IN} \times G = V_S$		3			See <sup>(2)</sup>		$\mu\text{s}$
THD+N	Total Harmonic Distortion + Noise	1 kHz, $G = 1$ , $V_O = 3.5\text{ V}_{rms}$		0.002%			See <sup>(2)</sup>		

**Electrical Characteristics for HGx277N, HGx277M, and HGx277x (continued)**

At  $T_A = 25^\circ\text{C}$ , and  $R_L = 2\text{ k}\Omega$ , unless otherwise noted

PARAMETER	TEST CONDITIONS	HG277N,M HG2277N,M			HG277x HG2277x HG4277x			UNIT
		MIN	TYP <sup>(1)</sup>	MAX	MIN	TYP <sup>(1)</sup>	MAX	
<b>OUTPUT</b>								
$V_O$	Voltage Output	$R_L = 10\text{ k}\Omega$	(V-) +0.5	(V+) -1.2	See <sup>(2)</sup>	See <sup>(2)</sup>	V	
		$T_A = 0^\circ\text{C}$ to $+65^\circ\text{C}$	(V-) +0.5	(V+) -1.2	See <sup>(2)</sup>	See <sup>(2)</sup>		
		$R_L = 2\text{ k}\Omega$	(V-) +1.5	(V+) -1.5	See <sup>(2)</sup>	See <sup>(2)</sup>		
		$T_A = 0^\circ\text{C}$ to $+65^\circ\text{C}$	(V-) +1.5	(V+) -1.5	See <sup>(2)</sup>	See <sup>(2)</sup>		
$I_{SC}$	Short-Circuit Current		$\pm 35$		See <sup>(2)</sup>		mA	
$C_{LOAD}$	Capacitive Load Drive		See <sup>(3)</sup>					
$Z_O$	Open-loop output impedance	$f = 1\text{ MHz}$	40		See <sup>(2)</sup>		$\Omega$	
<b>POWER SUPPLY</b>								
$V_S$	Specified Voltage Range		$\pm 5$	$\pm 15$	See <sup>(2)</sup>	See <sup>(2)</sup>	V	
	Operating Voltage Range		$\pm 2$	$\pm 18$	See <sup>(2)</sup>	See <sup>(2)</sup>	V	
$I_Q$	Quiescent Current (per amplifier)	$I_O = 0$	$\pm 790$	$\pm 825$	See <sup>(2)</sup>	See <sup>(2)</sup>	$\mu\text{A}$	
		$T_A = 0^\circ\text{C}$ to $65^\circ\text{C}$		$\pm 900$		See <sup>(2)</sup>		See <sup>(2)</sup>
<b>TEMPERATURE RANGE</b>								
	Specified Range		0	65	See <sup>(2)</sup>	See <sup>(2)</sup>	$^\circ\text{C}$	
	Operating Range		0	70	See <sup>(2)</sup>	See <sup>(2)</sup>	$^\circ\text{C}$	

(3) See [Typical Characteristics](#)

**Electrical Characteristics for HGx277DQ**

At  $T_A = 25^\circ\text{C}$ , and  $R_L = 2\text{ k}\Omega$ , unless otherwise noted

PARAMETER	TEST CONDITIONS	HG277DQ HG2277DQ			UNIT	
		MIN	TYP <sup>(1)</sup>	MAX		
<b>OFFSET VOLTAGE</b>						
$V_{OS}$	Input Offset Voltage		$\pm 35$	$\pm 100$	$\mu\text{V}$	
	Input Offset Voltage Over Temperature	HG277N, M (high-grade, single)	$T_A = 0^\circ\text{C}$ to $65^\circ\text{C}$		$\mu\text{V}$	
		HG2277N,M (high-grade, dual)				
		All Versions				
		AIDRM Versions		$\pm 165$		
$dV_{OS}/dT$	Input Offset Voltage Drift	HG277N,M (high-grade, single)	$T_A = 0^\circ\text{C}$ to $65^\circ\text{C}$		$\mu\text{V}/^\circ\text{C}$	
		HG2277N,M (high-grade, dual)				
		All AIDRM Versions		$\pm 0.15$		$\pm 1$
	Input Offset Voltage: (all models)	vs Time		See <sup>(2)</sup>	$\mu\text{V}/\text{mo}$	
		vs Power Supply (PSRR)	$V_S = \pm 2\text{ V}$ to $\pm 18\text{ V}$	See <sup>(2)</sup>	$\pm 1$	$\mu\text{V}/\text{V}$
			$T_A = 0^\circ\text{C}$ to $65^\circ\text{C}$		$\pm 1$	
	Channel Separation (dual, quad)	DC		See <sup>(2)</sup>	$\mu\text{V}/\text{V}$	

(1)  $V_S = \pm 15\text{ V}$

(2) Specifications are the same as HG277N,M

**Electrical Characteristics for HGx277DQ (continued)**

At  $T_A = 25^\circ\text{C}$ , and  $R_L = 2\text{ k}\Omega$ , unless otherwise noted

PARAMETER		TEST CONDITIONS	HG277DQ HG2277DQ			UNIT
			MIN	TYP <sup>(1)</sup>	MAX	
<b>INPUT BIAS CURRENT</b>						
$I_B$	Input Bias Current	$T_A = 0^\circ\text{C to } 65^\circ\text{C}$			$\pm 2.8$ $\pm 4$	nA
$I_{OS}$	Input Offset Current	$T_A = 0^\circ\text{C to } 65^\circ\text{C}$			$\pm 2.8$ $\pm 4$	nA
<b>NOISE</b>						
	Input Voltage Noise, $f = 0.1$ to $10\text{ Hz}$			See <sup>(2)</sup>		$\mu\text{V}_{PP}$
$e_n$	Input Voltage Noise Density		$f = 10\text{ Hz}$	See <sup>(2)</sup>		nV/ $\sqrt{\text{Hz}}$
			$f = 100\text{ Hz}$	See <sup>(2)</sup>		
			$f = 1\text{ kHz}$	See <sup>(2)</sup>		
			$f = 10\text{ kHz}$	See <sup>(2)</sup>		
$i_n$	Current Noise Density, $f = 1\text{ kHz}$			See <sup>(2)</sup>		pA/ $\sqrt{\text{Hz}}$
<b>INPUT VOLTAGE RANGE</b>						
$V_{CM}$	Common-Mode Voltage Range			See <sup>(2)</sup>	See <sup>(2)</sup>	V
CMRR	Common-Mode Rejection	$V_{CM} = (V^-) + 2\text{ V to } (V^+) - 2\text{ V}$ $T_A = 0^\circ\text{C to } 65^\circ\text{C}$	115	See <sup>(2)</sup>		dB
<b>INPUT IMPEDANCE</b>						
	Differential			See <sup>(2)</sup>		M $\Omega$    pF
	Common-Mode	$V_{CM} = (V^-) + 2\text{ V to } (V^+) - 2\text{ V}$		See <sup>(2)</sup>		G $\Omega$    pF
<b>OPEN-LOOP GAIN</b>						
$A_{OL}$	Open-Loop Voltage Gain		$V_O = (V^-) + 0.5\text{ V to } (V^+) - 1.2\text{ V}$ , $R_L = 10\text{ k}\Omega$	See <sup>(2)</sup>		dB
			$V_O = (V^-) + 1.5\text{ V to } (V^+) - 1.5\text{ V}$ , $R_L = 2\text{ k}\Omega$	See <sup>(2)</sup>	See <sup>(2)</sup>	
			$V_O = (V^-) + 1.5\text{ V to } (V^+) - 1.5\text{ V}$ , $R_L = 2\text{ k}\Omega$ $T_A = 0^\circ\text{C to } 65^\circ\text{C}$	See <sup>(2)</sup>		dB
<b>FREQUENCY RESPONSE</b>						
GBW	Gain-Bandwidth Product			See <sup>(2)</sup>		MHz
SR	Slew Rate			See <sup>(2)</sup>		V/ $\mu\text{s}$
	Settling Time		0.1%	$V_S = \pm 15\text{ V}$ , $G = 1$ , 10-V Step	See <sup>(2)</sup>	$\mu\text{s}$
			0.01%		See <sup>(2)</sup>	
	Overload Recovery Time		$V_{IN} \times G = V_S$	See <sup>(2)</sup>		$\mu\text{s}$
THD+N	Total Harmonic Distortion + Noise		1 kHz, $G = 1$ , $V_O = 3.5\text{ V}_{rms}$	See <sup>(2)</sup>		
<b>OUTPUT</b>						
$V_O$	Voltage Output		$R_L = 10\text{ k}\Omega$	See <sup>(2)</sup>	See <sup>(2)</sup>	V
			$T_A = 0^\circ\text{C to } +65^\circ\text{C}$	See <sup>(2)</sup>	See <sup>(2)</sup>	
			$R_L = 2\text{ k}\Omega$	See <sup>(2)</sup>	See <sup>(2)</sup>	
			$T_A = 0^\circ\text{C to } +65^\circ\text{C}$	See <sup>(2)</sup>	See <sup>(2)</sup>	
$I_{SC}$	Short-Circuit Current			See <sup>(2)</sup>		mA
$C_{LOAD}$	Capacitive Load Drive					
$Z_O$	Open-loop output impedance		$f = 1\text{ MHz}$	See <sup>(2)</sup>		$\Omega$



**Electrical Characteristics for HGx277DQ (continued)**

At  $T_A = 25^\circ\text{C}$ , and  $R_L = 2\text{ k}\Omega$ , unless otherwise noted

PARAMETER		TEST CONDITIONS	HG277DQ HG2277DQ			UNIT
			MIN	TYP <sup>(1)</sup>	MAX	
<b>POWER SUPPLY</b>						
$V_S$	Specified Voltage Range		See <sup>(2)</sup>		See <sup>(2)</sup>	V
	Operating Voltage Range		See <sup>(2)</sup>		See <sup>(2)</sup>	V
$I_Q$	Quiescent Current (per amplifier)	$I_O = 0$		See <sup>(2)</sup>	See <sup>(2)</sup>	$\mu\text{A}$
		$T_A = 0^\circ\text{C to } 65^\circ\text{C}$			See <sup>(2)</sup>	
<b>TEMPERATURE RANGE</b>						
	Specified Range		See <sup>(2)</sup>		See <sup>(2)</sup>	$^\circ\text{C}$
	Operating Range		See <sup>(2)</sup>		See <sup>(2)</sup>	$^\circ\text{C}$

**Typical Characteristics**

At  $T_A = 25^\circ\text{C}$ ,  $V_S = \pm 15\text{ V}$ , and  $R_L = 2\text{ k}\Omega$ , unless otherwise noted.

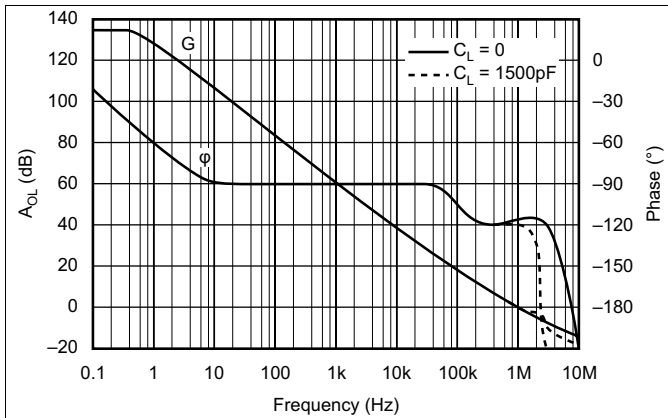

**Figure 1. Open-Loop Gain and Phase vs Frequency**

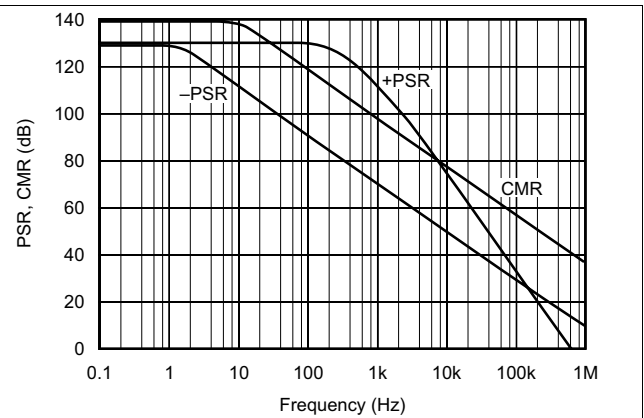

**Figure 2. Power Supply and Common-Mode Rejection vs Frequency**

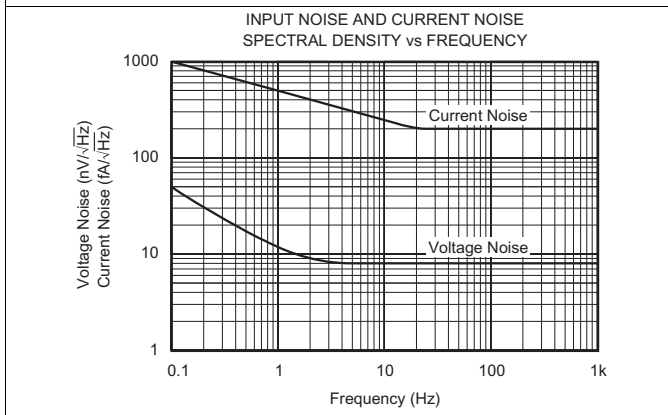

**Figure 3. Input Noise and Current Noise Spectral Density vs Frequency**

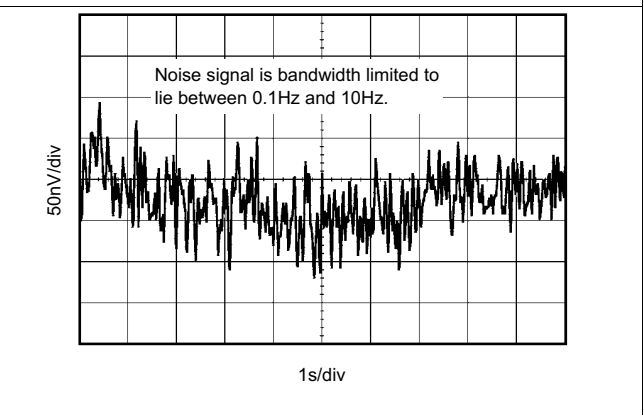

**Figure 4. Input Noise Voltage vs Time**

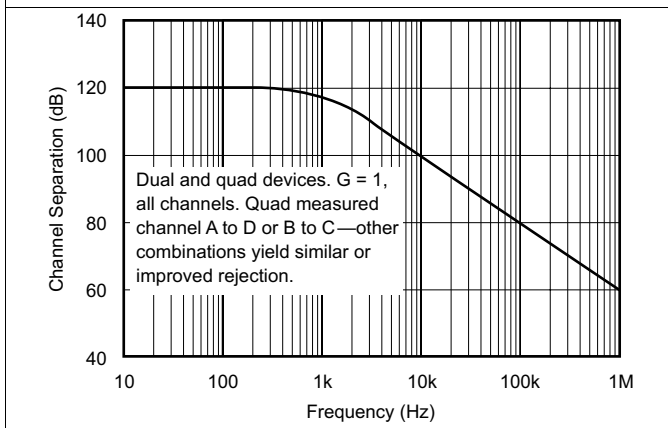

**Figure 5. Channel Separation vs Frequency**

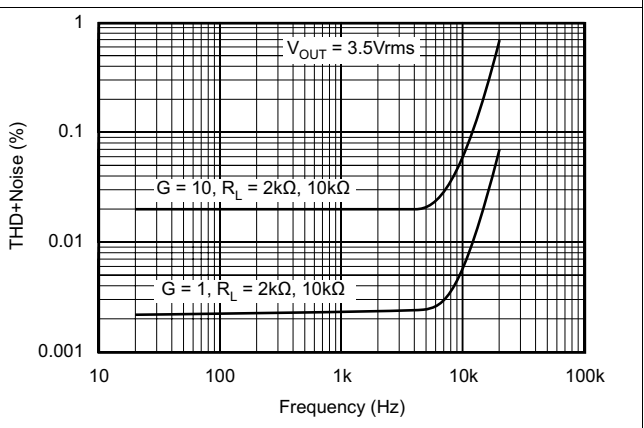

**Figure 6. Total Harmonic Distortion + Noise vs Frequency**

**Typical Characteristics (continued)**

At  $T_A = 25^\circ\text{C}$ ,  $V_S = \pm 15\text{ V}$ , and  $R_L = 2\text{ k}\Omega$ , unless otherwise noted.

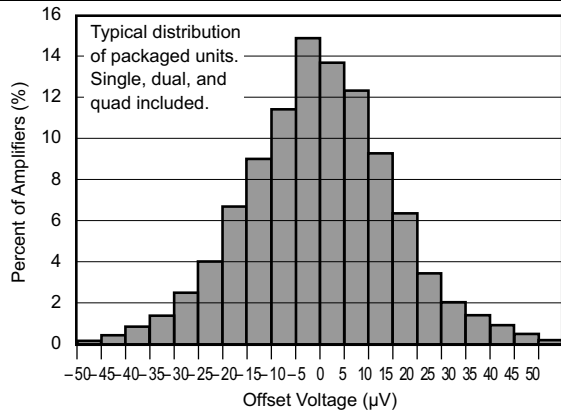

**Figure 7. Offset Voltage Production Distribution**

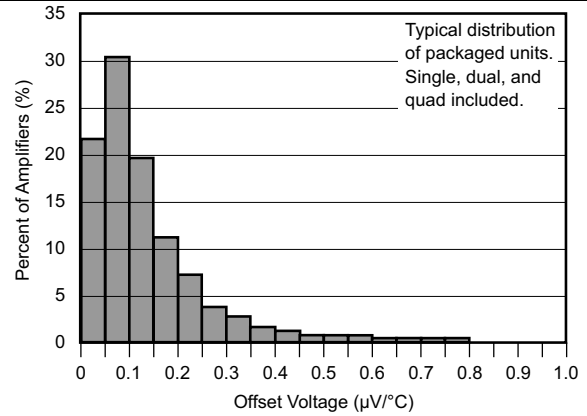

**Figure 8. Offset Voltage Drift Production Distribution**

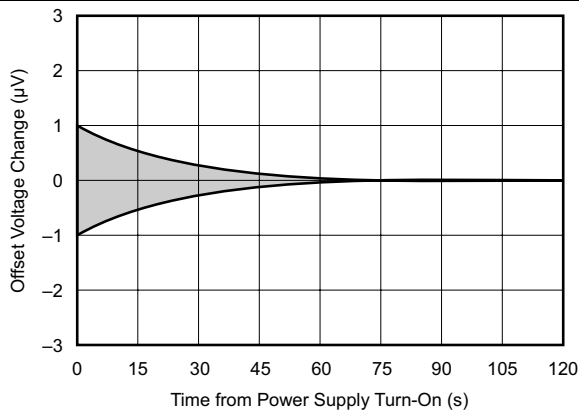

**Figure 9. Warm-Up Offset Voltage Drift**

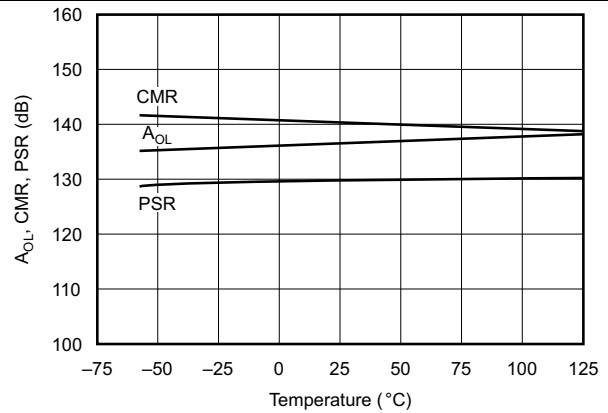

**Figure 10.  $A_{OL}$ , CMR, PSR vs Temperature**

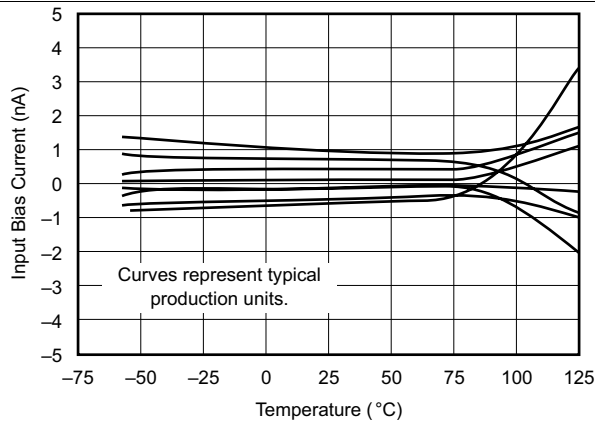

**Figure 11. Input Bias Current vs Temperature**

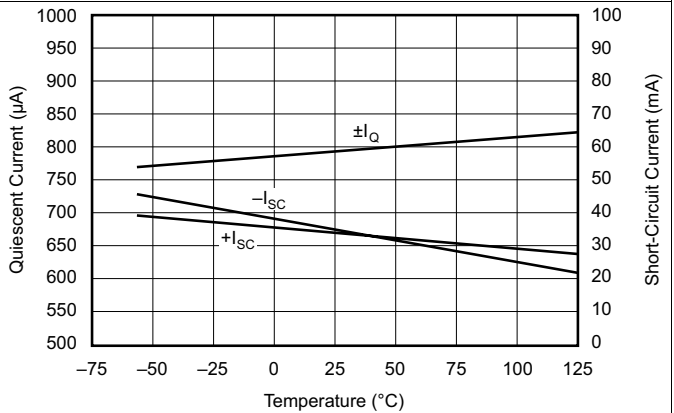

**Figure 12. Quiescent Current and Short-Circuit Current vs Temperature**

**Typical Characteristics (continued)**

At  $T_A = 25^\circ\text{C}$ ,  $V_S = \pm 15\text{ V}$ , and  $R_L = 2\text{ k}\Omega$ , unless otherwise noted.

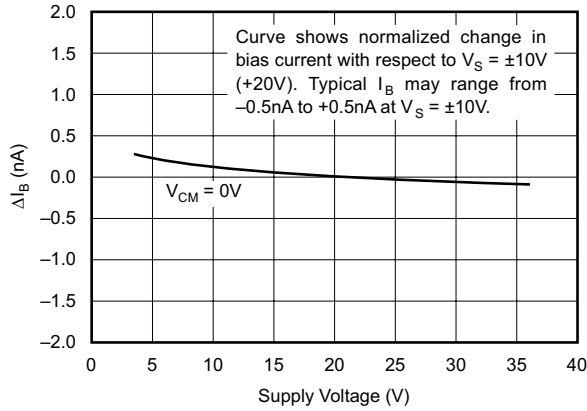

**Figure 13. Change in Input Bias Current vs Power Supply Voltage**

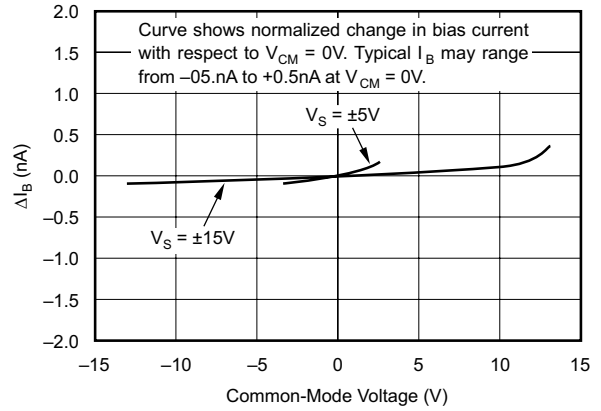

**Figure 14. Change in Input Bias Current vs Common-Mode Voltage**

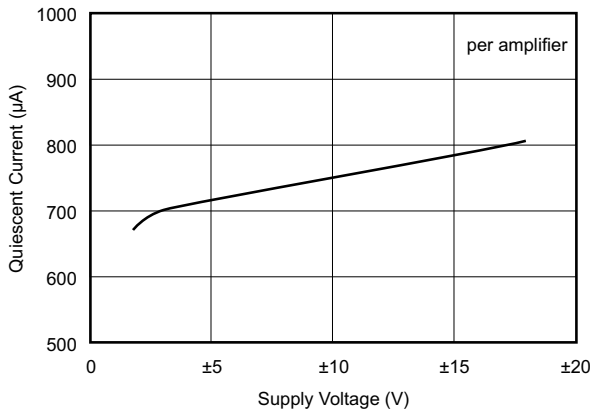

**Figure 15. Quiescent Current vs Supply Voltage**

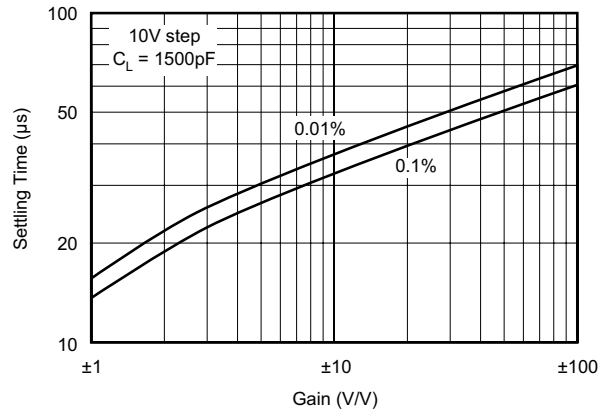

**Figure 16. Settling Time vs Closed-Loop Gain**

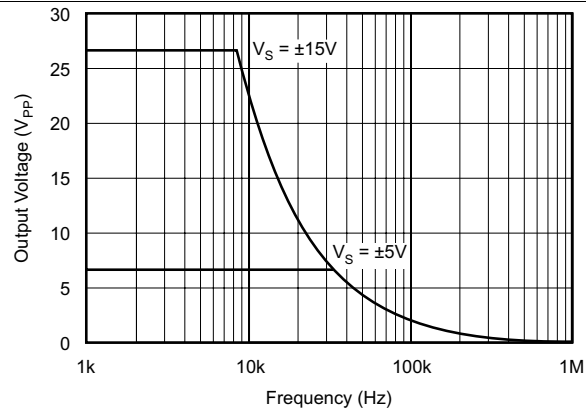

**Figure 17. Maximum Output Voltage vs Frequency**

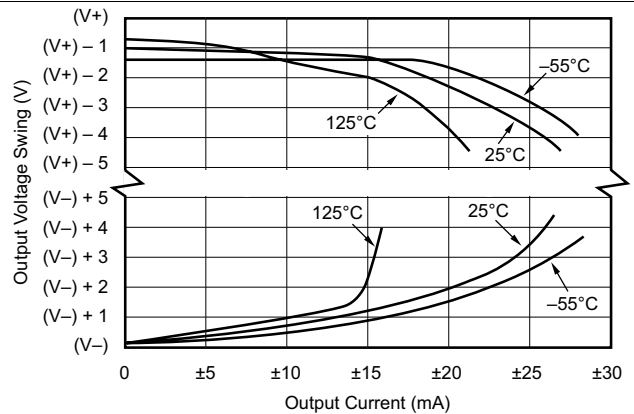

**Figure 18. Output Voltage Swing vs Output Current**

**Typical Characteristics (continued)**

At  $T_A = 25^\circ\text{C}$ ,  $V_S = \pm 15\text{ V}$ , and  $R_L = 2\text{ k}\Omega$ , unless otherwise noted.

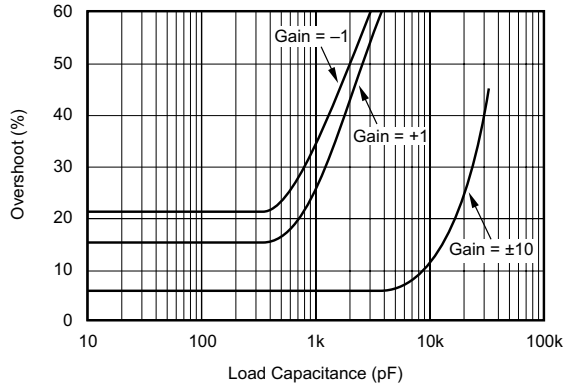

**Figure 19. Small-Signal Overshoot vs Load Capacitance**

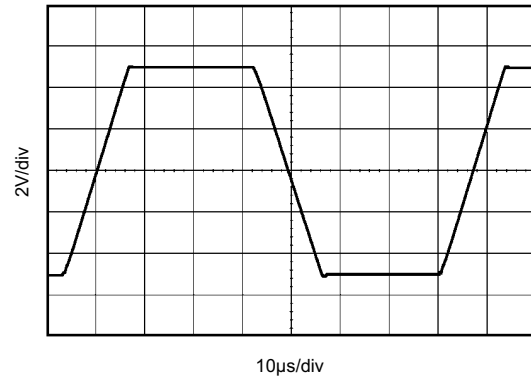

**Figure 20. Large-Signal Step Response**  
 $G = 1$ ,  $C_L = 1500\text{ pF}$ ,  $V_S = \pm 15\text{ V}$

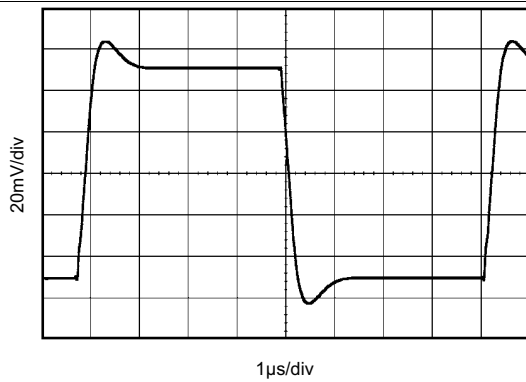

**Figure 21. Small-Signal Step Response**  
 $G = +1$ ,  $C_L = 0$ ,  $V_S = \pm 15\text{ V}$

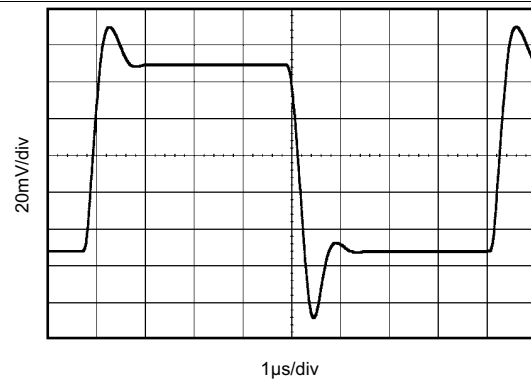

**Figure 22. Small-Signal Step Response**  
 $G = 1$ ,  $C_L = 1500\text{ pF}$ ,  $V_S = \pm 15\text{ V}$

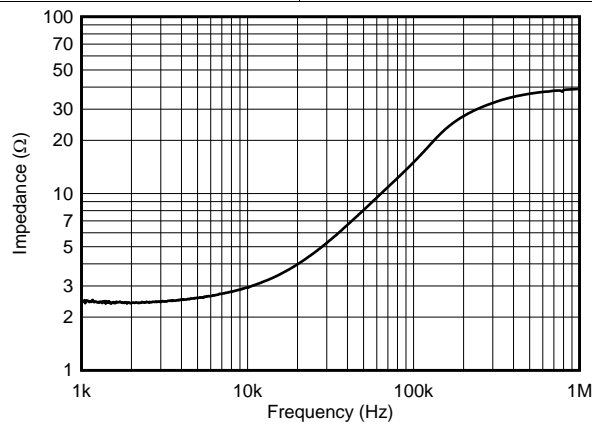

**Figure 23. Open-Loop Output Impedance**  
 $V_S = \pm 15\text{ V}$

## Detailed Description

### Overview

The HGx277 series precision operational amplifiers replace the industry standard HG-177. They offer improved noise, wider output voltage swing, and are twice as fast with half the quiescent current. Features include ultralow offset voltage and drift, low bias current, high common-mode rejection, and high power supply rejection. Single, dual, and quad versions have identical specifications, for maximum design flexibility.

### Functional Block Diagram

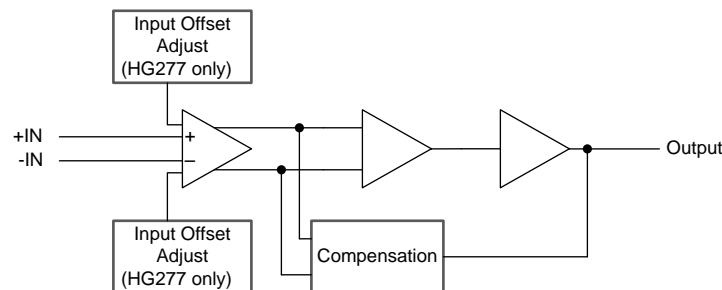

### Feature Description

The HGx277 series is unity-gain stable and free from unexpected output phase reversal, making it easy to use in a wide range of applications. Applications with noisy or high-impedance power supplies may require decoupling capacitors close to the device pins. In most cases 0.1- $\mu$ F capacitors are adequate.

The HGx277 series has low offset voltage and drift. To achieve highest performance, the circuit layout and mechanical conditions should be optimized. Offset voltage and drift can be degraded by small thermoelectric potentials at the operational amplifier inputs. Connections of dissimilar metals generate thermal potential, which can degrade the ultimate performance of the HGx277 series. These thermal potentials can be made to cancel by assuring that they are equal in both input terminals.

- Keep the thermal mass of the connections to the two input terminals similar
- Locate heat sources as far as possible from the critical input circuitry
- Shield operational amplifier and input circuitry from air currents, such as cooling fans

### Operating Voltage

HGx277 series operational amplifiers operate from  $\pm 2$ -V to  $\pm 18$ -V supplies with excellent performance. Unlike most operational amplifiers, which are specified at only one supply voltage, the HG277 series is specified for real-world applications; a single limit applies over the  $\pm 5$ -V to  $\pm 15$ -V supply range. This allows a customer operating at  $V_S = \pm 10$  V to have the same assured performance as a customer using  $\pm 15$ -V supplies. In addition, key parameters are assured over the specified temperature range, 0 °C to 65°C. Most behavior remains unchanged through the full operating voltage range ( $\pm 2$  V to  $\pm 18$  V). Parameters which vary significantly with operating voltage or temperature are shown in [Typical Characteristics](#).

### Offset Voltage Adjustment

The HGx277 series is laser-trimmed for low offset voltage and drift, so most circuits do not require external adjustment. However, offset voltage trim connections are provided on pins 1 and 8. Offset voltage can be adjusted by connecting a potentiometer, as shown in [Figure 24](#). Only use this adjustment to null the offset of the operational amplifier. This adjustment should not be used to compensate for offsets created elsewhere in a system, because this can introduce additional temperature drift.

**Feature Description (continued)**

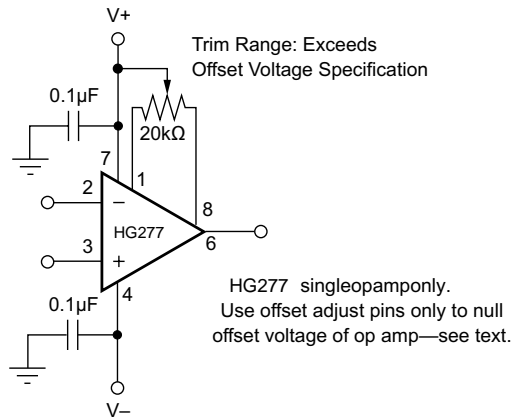

**Figure 24. HG277 Offset Voltage Trim Circuit**

**Input Protection**

The inputs of the HGx277 series are protected with 1-kΩ series input resistors and diode clamps. The inputs can withstand ±30-V differential inputs without damage. The protection diodes conduct current when the inputs are over-driven. This may disturb the slewing behavior of unity-gain follower applications, but will not damage the operational amplifier.

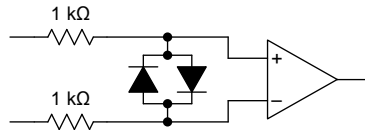
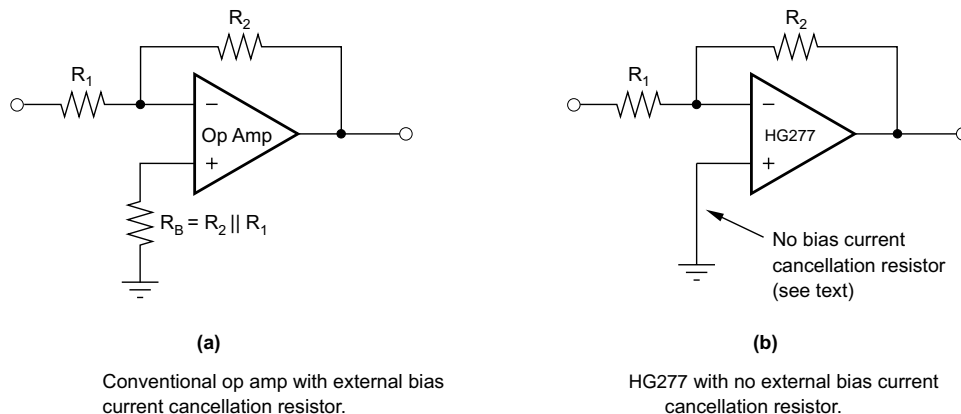

**Figure 25. HGx277 Input Protection**

**Input Bias Current Cancellation**

The input stage base current of the HGx277 series is internally compensated with an equal and opposite cancellation circuit. The resulting input bias current is the difference between the input stage base current and the cancellation current. This residual input bias current can be positive or negative.

When the bias current is canceled in this manner, the input bias current and input offset current are approximately the same magnitude. As a result, it is not necessary to use a bias current cancellation resistor, as is often done with other operational amplifiers (see Figure 26). A resistor added to cancel input bias current errors may actually increase offset voltage and noise.



**Figure 26. Input Bias Current Cancellation**

**Feature Description (continued)**

**EMI Rejection Ratio (EMIRR)**

The electromagnetic interference (EMI) rejection ratio, or EMIRR, describes the EMI immunity of operational amplifiers. An adverse effect that is common to many operational amplifiers is a change in the offset voltage as a result of RF signal rectification. An operational amplifier that is more efficient at rejecting this change in offset as a result of EMI has a higher EMIRR and is quantified by a decibel value. Measuring EMIRR can be performed in many ways, but this report provides the EMIRR IN+, which specifically describes the EMIRR performance when the RF signal is applied to the noninverting input pin of the operational amplifier. In general, only the noninverting input is tested for EMIRR for the following three reasons:

1. Operational amplifier input pins are known to be the most sensitive to EMI, and typically rectify RF signals better than the supply or output pins.
2. The noninverting and inverting operational amplifier inputs have symmetrical physical layouts and exhibit nearly matching EMIRR performance.
3. EMIRR is easier to measure on noninverting pins than on other pins because the noninverting input terminal can be isolated on a printed circuit board (PCB). This isolation allows the RF signal to be applied directly to the noninverting input terminal with no complex interactions from other components or connecting PCB traces.

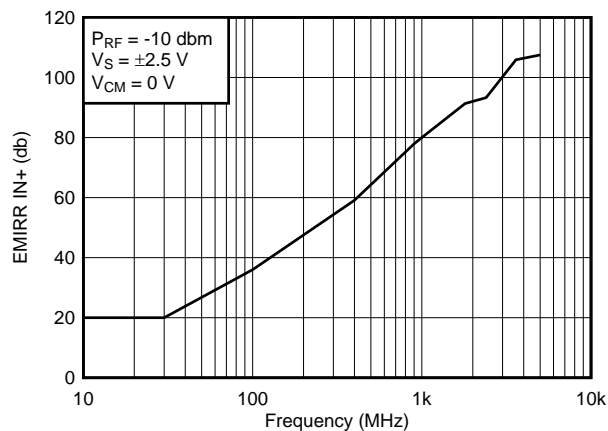

**Figure 27. HG277 EMIRR IN+ vs Frequency**

If available, any dual and quad operational amplifier device versions have nearly similar EMIRR IN+ performance. The HG277 unity-gain bandwidth is 1 MHz. EMIRR performance below this frequency denotes interfering signals that fall within the operational amplifier bandwidth.



**Feature Description (continued)**

Table 1 shows the EMIRR IN+ values for the HG277 at particular frequencies commonly encountered in real-world applications. Applications listed in Table 1 may be centered on or operated near the particular frequency shown. This information may be of special interest to designers working with these types of applications, or working in other fields likely to encounter RF interference from broad sources, such as the industrial, scientific, and medical (ISM) radio band.

**Table 1. HG277 EMIRR IN+ for Frequencies of Interest**

FREQUENCY	APPLICATION/ALLOCATION	EMIRR IN+
400 MHz	Mobile radio, mobile satellite/space operation, weather, radar, UHF	59.1 dB
900 MHz	GSM, radio com/nav./GPS (to 1.6 GHz), ISM, aeronautical mobile, UHF	77.9 dB
1.8 GHz	GSM, mobile personal comm. broadband, satellite, L-band	91.3 dB
2.4 GHz	802.11b/g/n, Bluetooth™, mobile personal comm., ISM, amateur radio/satellite, S-band	93.3 dB
3.6 GHz	Radiolocation, aero comm./nav., satellite, mobile, S-band	105.9 dB
5.0 GHz	802.11a/n, aero comm./nav., mobile comm., space/satellite operation, C-band	107.5 dB

**EMIRR IN+ Test Configuration**

Figure 28 shows the circuit configuration for testing the EMIRR IN+. An RF source is connected to the operational amplifier noninverting input terminal using a transmission line. The operational amplifier is configured in a unity gain buffer topology with the output connected to a low-pass filter (LPF) and a digital multimeter (DMM). Note that a large impedance mismatch at the operational amplifier input causes a voltage reflection; however, this effect is characterized and accounted for when determining the EMIRR IN+. The resulting dc offset voltage is sampled and measured by the multimeter. The LPF isolates the multimeter from residual RF signals that may interfere with multimeter accuracy.

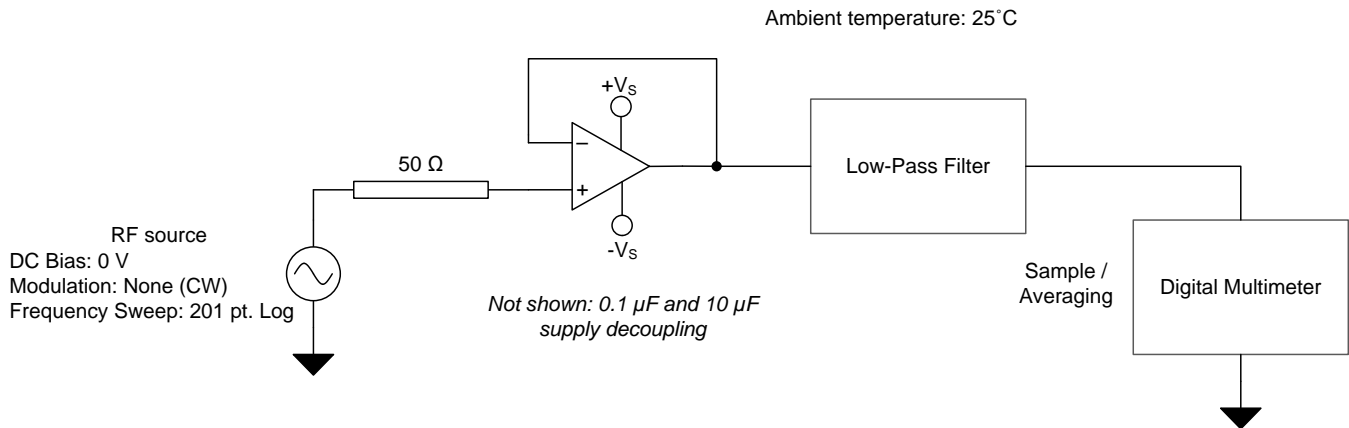

**Figure 28. EMIRR IN+ Test Configuration Schematic**

**Device Functional Modes**

The HGx277 has a single functional mode and is operational when the power-supply voltage is greater than 4 V (±2 V). The maximum power supply voltage for the HGx277 is 36 V (±18 V).

## Application and Implementation

### Application Information

The HGx277 family offers outstanding dc precision and ac performance. These devices operate up to 36-V supply rails and offer ultralow offset voltage and offset voltage drift, as well as 1-MHz bandwidth and high capacitive load drive. These features make the HGx277 a robust, high-performance operational amplifier for high-voltage industrial applications.

### Typical Applications

#### Second-Order Lowpass Filter

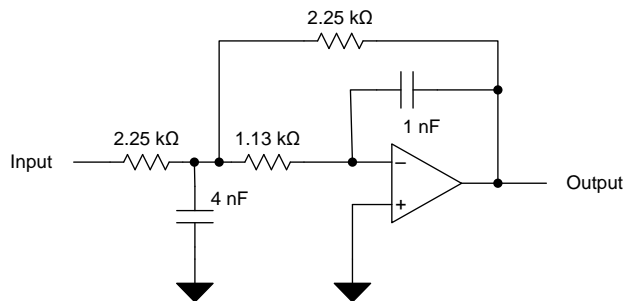

Figure 29. Second-Order Lowpass Filter

#### Design Requirements

- Gain = 1 V/V
- Lowpass cutoff frequency = 50 kHz
- -40 db/dec filter response
- Maintain less than 3-dB gain peaking in the gain versus frequency response

Typical Applications (continued)

Application Curve

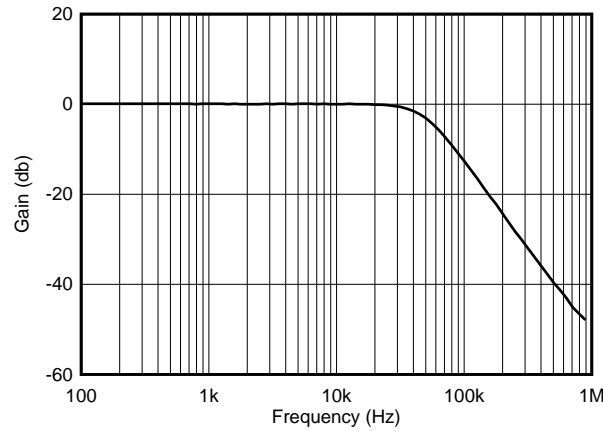

Figure 30. HG277 Second-Order 50-kHz, Lowpass Filter

Load Cell Amplifier

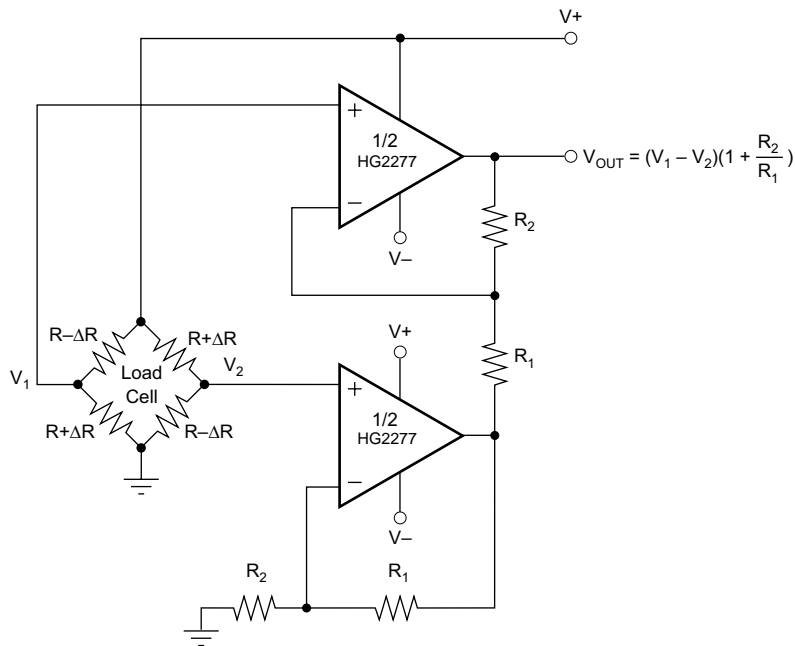
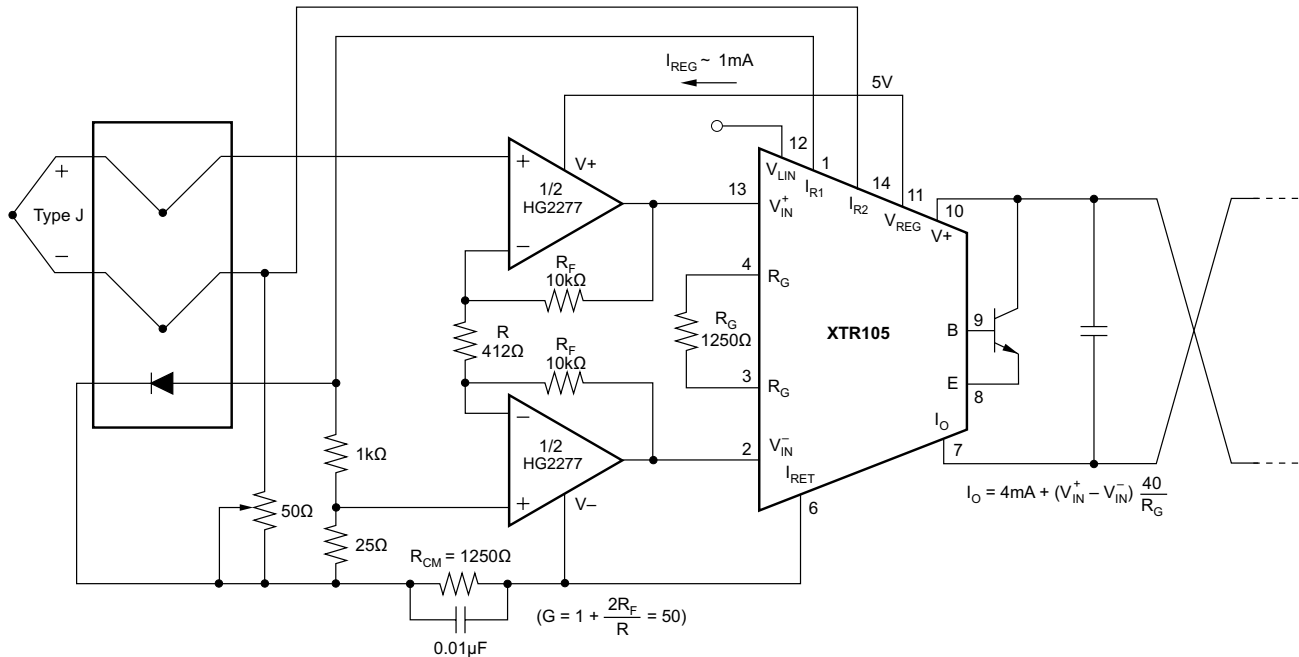

Figure 31. Load Cell Amplifier

**Typical Applications (continued)**

**Thermocouple Low-Offset, Low-Drift Loop Measurement With Diode Cold Junction Compensation**



**Figure 32. Thermocouple Low-Offset, Low-Drift Loop Measurement With Diode Cold Junction Compensation**

**DFN Package**

The HGx277 series uses the 8-lead DFN (also known as SON), a QFN package with contacts on only two sides of the package bottom. This leadless, near-chip-scale package maximizes board space and enhances thermal and electrical characteristics through an exposed pad.

DFN packages are physically small, have a smaller routing area, improved thermal performance, and improved electrical parasitics, with a pinout scheme that is consistent with other commonly-used packages, such as SO and MSOP. Additionally, the absence of external leads eliminates bent-lead issues.

The exposed leadframe die pad on the bottom of the package should be connected to V-.

**PACKAGE**

SOP8

The SOP8 package is shown in two views. The top view shows a rectangular package with dimensions B (width) and C (height). The lead width is labeled 'a' and the lead spacing is 'b'. The lead height is 'C1'. The side view shows the lead height 'A', the lead thickness 'A1', the lead width 'D', and the lead angle 'Q'. A dimension of 0.25 is also indicated for the lead thickness.

Dimensions In Millimeters					
Symbol :	Min :	Max :	Symbol :	Min :	Max :
A	1.225	1.570	D	0.400	0.950
A1	0.100	0.250	Q	0°	8°
B	4.800	5.100	a	0.420 TYP	
C	5.800	6.250	b	1.270 TYP	
C1	3.800	4.000			

DIP8

The DIP8 package is shown in three views. The top view shows dimensions B (width) and E (height). The lead width is 'a' and the lead spacing is 'b'. The lead height is 'L1'. The side view shows the lead height 'L', the lead width 'D', and the lead angle 'D1'. The bottom view shows the package width 'A' and the lead width 'a' and 'b'. The lead height is 'L'.

Dimensions In Millimeters					
Symbol :	Min :	Max :	Symbol :	Min :	Max :
A	6.100	6.680	L1	3.000	3.600
B	9.000	9.500	a	1.524 TYP	
D	8.400	9.000	b	0.889 TYP	
D1	7.420	7.820	c	0.457 TYP	
E	3.100	3.550	d	2.540 TYP	
L	0.500	0.700			

**PACKAGE**

SOP14

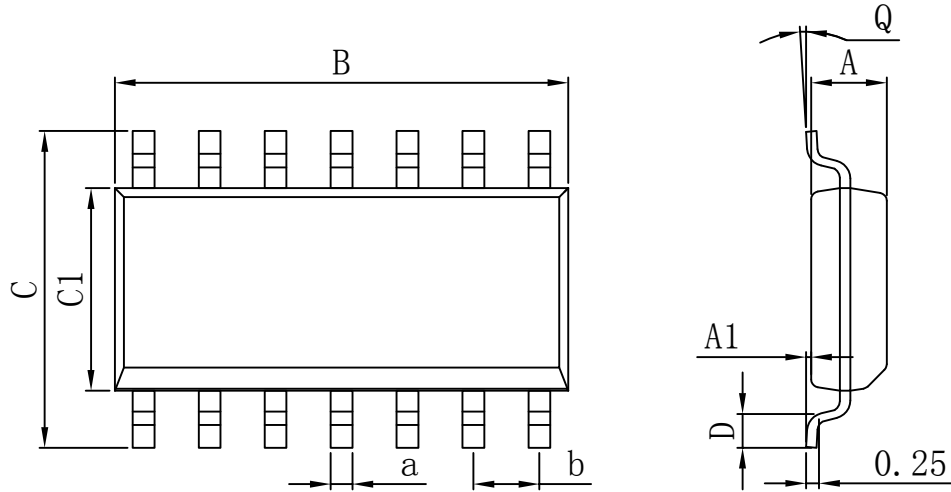

Dimensions In Millimeters					
Symbol :	Min :	Max :	Symbol :	Min :	Max :
A	1.225	1.570	D	0.400	0.950
A1	0.100	0.250	Q	0°	8°
B	8.500	9.000	a	0.420 TYP	
C	5.800	6.250	b	1.270 TYP	
C1	3.800	4.000			

DIP14

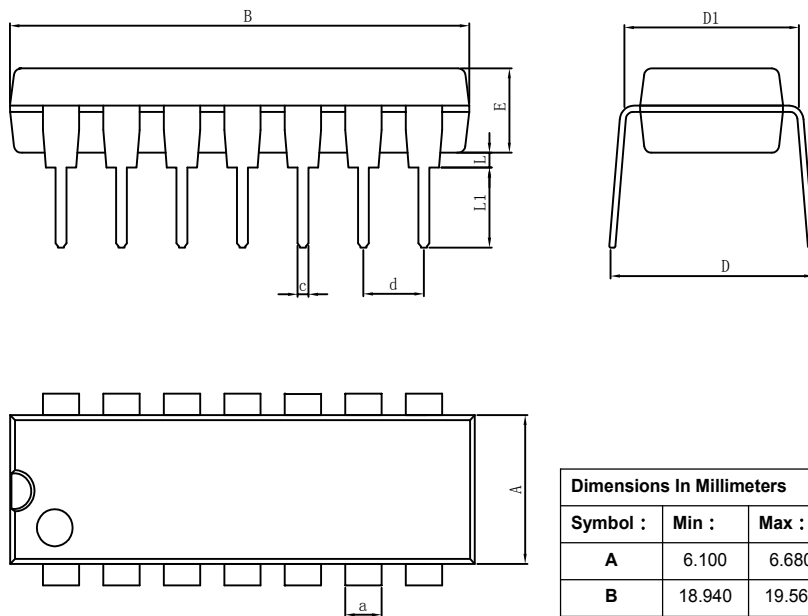

Dimensions In Millimeters					
Symbol :	Min :	Max :	Symbol :	Min :	Max :
A	6.100	6.680	L	0.500	0.800
B	18.940	19.560	L1	3.000	3.600
D	8.200	9.200	a	1.524 TYP	
D1	7.42	7.820	c	0.457 TYP	
E	3.100	3.550	d	2.540 TYP	

**PACKAGE**

DFN-8

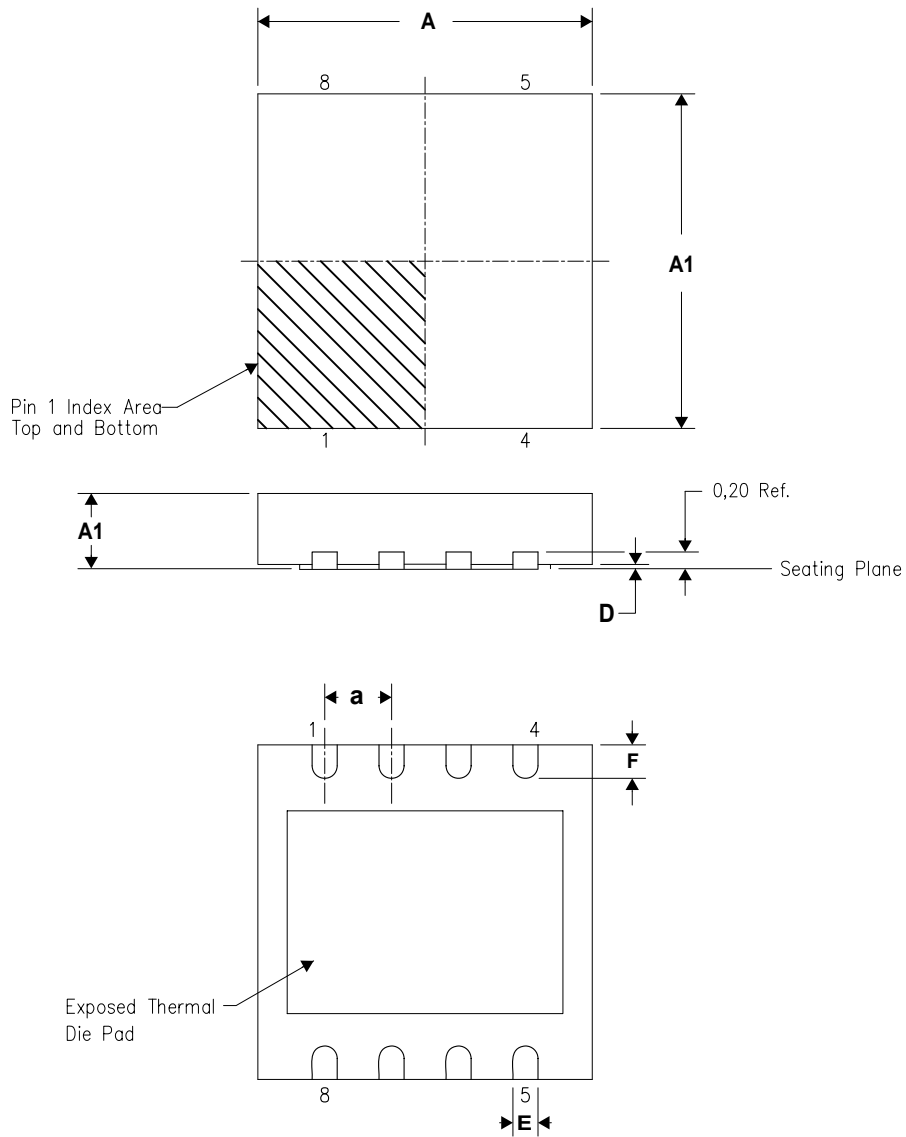

Dimensions In Millimeters					
Symbol :	Min :	Max :	Symbol :	Min :	Max :
<b>A</b>	3.900	4.100	<b>E</b>	0.230	0.380
<b>A1</b>	3.900	4.100	<b>F</b>	0.300	0.500
<b>B</b>	0.800	1.000	<b>a</b>	0.80 TYP	
<b>D</b>	0.000	0.050			

Important statement:

Huaguan Semiconductor Co,Ltd. reserves the right to change the products and services provided without notice. Customers should obtain the latest relevant information before ordering, and verify the timeliness and accuracy of this information.

Customers are responsible for complying with safety standards and taking safety measures when using our products for system design and machine manufacturing to avoid potential risks that may result in personal injury or property damage.

Our products are not licensed for applications in life support, military, aerospace, etc., so we do not bear the consequences of the application of these products in these fields.

Our documentation is only permitted to be copied without any tampering with the content, so we do not accept any responsibility or liability for the altered documents.