

Incremental encoders

| | | |
|------------------------|---|---|
| Compact optical | Sendix Base KIS40 / KIH40 (shaft / hollow shaft) | Push-pull / RS422 / Open collector |
|------------------------|---|---|

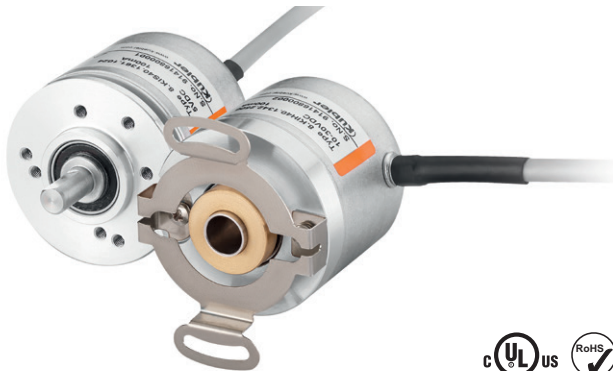

The incremental encoders type Sendix Base KIS40 / KIH40 with optical sensor technology have been designed for highest cost-effectiveness. They are available with a resolution of up to 2560 pulses per revolution.

They are particularly suitable for tight mounting spaces and small machines and appliances.



| | | | | | | | |
|--------------|-----------------------|-------------------|-----------------------------|---------------------|-----------------------------|----------------------|----------------|
| | | | | | | | |
| Safety-Lock™ | High rotational speed | Temperature range | Shock / vibration resistant | Short-circuit proof | Reverse polarity protection | Magnetic field proof | Optical sensor |

Compact and robust

- Only 40 mm outer diameter.
- Ideally suited for use where space is tight.
- Sturdy bearing construction in Safety Lock™ design.
- Safe commissioning: reverse polarity protection and short-circuit proof.

Flexible

- Maximum resolution of 2560 pulses per revolution.
- Supply voltage 5 V DC, 10 ... 30 V DC or 5 ... 30 V DC.
- Push-pull, RS422 or open collector
- Radial or axial cable.

| | | | | |
|----------------------|----------------|-----------------|---------------|---------------------------|
| Order code | 8.KIS40 | . 1 XXXX | . XXXX | . P03¹⁾ |
| Shaft version | Type | a b c d | e | f |

a Flange

1 = clamping-synchro flange, ø 40 mm [1.57"]

b Shaft (ø x L)

3 = ø 6 x 12.5 mm [0.24 x 0.49"], with flat
 5 = ø 1/4" x 12.5 mm [1/4" x 0.49"], with flat
 6 = ø 8 x 12.5 mm [0.32 x 0.49"], with flat

c Output circuit / supply voltage

3 = open collector NPN (with inverted signal) / 10 ... 30 V DC
 4 = push-pull (with inverted signal) / 10 ... 30 V DC
 6 = RS422 (with inverted signal) / 5 V DC
 7 = open collector NPN (without inverted signal) / 10 ... 30 V DC
 8 = push-pull (without inverted signal) / 10 ... 30 V DC
 A = open collector NPN (with inverted signal) / 5 ... 30 V DC
 B = push-pull (with inverted signal) / 5 ... 30 V DC
 C = RS422 (with inverted signal) / 5 ... 30 V DC

d Type of connection

1 = axial cable, 2 m [6.56'] PVC
 2 = radial cable, 2 m [6.56'] PVC
 4 = radial cable, 0.5 m [1.64'] PVC, with M12 connector, 5-pin
 6 = radial cable, 0.5 m [1.64'] PVC, with M12 connector, 8-pin
 A = axial cable, special length PVC *)
 B = radial cable, special length PVC *)

*) Available special lengths (connection types A, B):
 3, 5, 8, 10, 15 m [9.84, 16.40, 26.25, 32.80, 49.21']
 order code expansion .XXXX = length in dm
 e.g.: 8.KIS40.134A.1024. (P03.) 0050 (for cable length 5 m)

e Pulse rate

10, 25, 50, 60, 88, 100, 120, 150, 200, 250, 314, 360, 500, 512, 600, 1000, 1024, 1500, 1800, 2000, 2048, 2500, 2560
 (e.g. 500 pulses => 0500)

f Special signal format

P03 = see page 4

Optional on request

- other pulse rates

1) Is only necessary when a special output signal format is required.

Incremental encoders

| | | |
|------------------------|---|---|
| Compact optical | Sendix Base KIS40 / KIH40 (shaft / hollow shaft) | Push-pull / RS422 / Open collector |
|------------------------|---|---|

| | | | | | |
|--|--|---------------|--------------|--------------------------|--|
| Order code | 8.KIH40 | .XXXXX | .XXXX | .P03¹⁾ | |
| Hollow shaft | Type | a b c d | e | f | |
| a Flange | 2 = with spring element, long 5 = with stator coupling, ø 46 mm [1.81"] | | | | e Pulse rate |
| b Blind hollow shaft (insertion depth max. 18 mm [0.71"]) | 2 = ø 6 mm [0.24"] 4 = ø 8 mm [0.32"] 3 = ø 1/4" | | | | 10, 25, 50, 60, 88, 100, 120, 150, 200, 250, 314, 360, 500, 512, 600, 1000, 1024, 1500, 1800, 2000, 2048, 2500, 2560 (e.g. 500 pulses => 0500) |
| c Output circuit / supply voltage | 3 = open collector NPN (with inverted signal) / 10 ... 30 V DC 4 = push-pull (with inverted signal) / 10 ... 30 V DC 6 = RS422 (with inverted signal) / 5 V DC 7 = open collector NPN (without inverted signal) / 10 ... 30 V DC 8 = push-pull (without inverted signal) / 10 ... 30 V DC A = open collector NPN (with inverted signal) / 5 ... 30 V DC B = push-pull (with inverted signal) / 5 ... 30 V DC C = RS422 (with inverted signal) / 5 ... 30 V DC | | | | f Special signal format |
| d Type of connection | 1 = axial cable, 2 m [6.56'] PVC 2 = radial cable, 2 m [6.56'] PVC 4 = radial cable, 0.5 m [1.64'] PVC, with M12 connector, 5-pin 6 = radial cable, 0.5 m [1.64'] PVC, with M12 connector, 8-pin A = axial cable, special length PVC *) B = radial cable, special length PVC *) | | | | P03 = see page 4 |
| *) Available special lengths (connection types A, B): | 3, 5, 8, 10, 15 m [9.84, 16.40, 26.25, 32.80, 49.21'] order code expansion .XXXX = length in dm ex.: 8.KIH40.544A.1024. (P03.) 0050 (for cable length 5 m) | | | | Optional on request - other pulse rates |

| | |
|--|---|
| Mounting accessory for shaft encoders | Order no. |
| Coupling | bellows coupling ø 15 mm [0.59"] for shaft 6 mm [0.24"] |
| | 8.0000.1202.0606 |

Further Kübler accessories can be found at: kuebler.com/accessories

1) Is only necessary when a special output signal format is required.

Incremental encoders

| | | |
|------------------------|---|---|
| Compact optical | Sendix Base KIS40 / KIH40 (shaft / hollow shaft) | Push-pull / RS422 / Open collector |
|------------------------|---|---|

Technical data

| Electrical characteristics | | | |
|---|--|--------------------------------------|--------------------------------|
| Output circuit | RS422 (TTL comp.) | Push-pull ¹⁾ (7272 comp.) | Open collector NPN (7273) |
| Supply voltage | 5 V DC (±5 %) / 5 ... 30 V DC | 10 ... 30 V DC / 5 ... 30 V DC | 10 ... 30 V DC / 5 ... 30 V DC |
| Power consumption with inverted signal (no load) | typ. 40 mA max. 90 mA / max. 165 mA | typ. 50 mA max. 100 mA | 100 mA |
| Permissible load / channel | max. +/- 20 mA | max. +/- 20 mA | 20 mA sink at 30 V DC |
| Pulse frequency | max. 250 kHz | max. 250 kHz | max. 250 kHz |
| Signal level | HIGH min. 2.5 V LOW max. 0.5 V | min. +V - 2.0 V max. 0.5 V | |
| Rising edge time t_r | max. 200 ns | max. 1 µs | |
| Falling edge time t_f | max. 200 ns | max. 1 µs | |
| Short circuit proof outputs ²⁾ | yes ³⁾ | yes | yes |
| Reverse polarity protection of the supply voltage | no/yes | yes | yes |

| Mechanical characteristics | | |
|---|---------|---|
| Maximum speed | | 4500 min ⁻¹ |
| Mass moment of inertia | | approx. 0.2 x 10 ⁻⁶ kgm ² |
| Starting torque – at 20 °C [68 °F] | | < 0.05 Nm |
| Shaft load capacity | radial | 40 N |
| | axial | 20 N |
| Weight | | ca. 0.17 kg [6.00 oz] |
| Protection acc. to EN 60529 | | IP64 |
| Working temperature range | | -20 °C ... +70 °C [-4 °F ... +158 °F] |
| Materials | shaft | stainless steel |
| | flange | aluminum |
| | housing | aluminum |
| | cable | PVC |
| Shock resistance acc. to EN 60068-2-27 | | 1000 m/s ² , 6 ms |
| Vibration resistance acc. to EN 60068-2-6 | | 100 m/s ² , 55 ... 2000 Hz |

| Approvals | |
|--|---------------------------------|
| UL compliant in accordance with | File no. E224618 |
| CE compliant in accordance with | EMC Directive 2014/30/EU |
| | RoHS Directive 2011/65/EU |
| UKCA compliant in accordance with | EMC Regulations S.I. 2016/1091 |
| | RoHS Regulations S.I. 2012/3032 |

1) Max. recommended cable length 30 m [98.43'].
 2) If supply voltage correctly applied.
 3) Only one channel allowed to be shorted-out:
 at +V= 5 V DC, short-circuit to channel, 0 V, or +V is permitted.
 at +V= 5 ... 30 V DC, short-circuit to channel or 0 V is permitted.

Incremental encoders

Compact optical

Sendix Base KIS40 / KIH40 (shaft / hollow shaft)

Push-pull / RS422 / Open collector

Terminal assignment

| Output circuit | Type of connection | Cable (isolate unused cores individually before initial start-up) | | | | | | | | |
|--------------------------------------|--------------------|---|-----|----|----|-----------|----|-----------|----|-----------|
| 3, 4, 6, A, B, C with inv. signal | 1, 2, A, B | Signal: | 0 V | +V | A | \bar{A} | B | \bar{B} | 0 | $\bar{0}$ |
| | | Core color: | WH | BN | GN | YE | GY | PK | BU | RD |

| Output circuit | Type of connection | Cable (isolate unused cores individually before initial start-up) | | | | | | | | |
|-----------------------------|--------------------|---|-----|----|----|---|----|---|----|---|
| 7, 8 without inv. signal | 1, 2, A, B | Signal: | 0 V | +V | A | – | B | – | 0 | – |
| | | Core color: | WH | BN | GN | – | GY | – | BU | – |

| Output circuit | Type of connection | M12 connector, 8-pin | | | | | | | | | |
|---|--------------------|----------------------|-----|----|---|-----------|---|-----------|---|-----------|------------------|
| 3, 4, 6, A, B, C without inv. signal | 6 | Signal: | 0 V | +V | A | \bar{A} | B | \bar{B} | 0 | $\bar{0}$ | \perp |
| | | Pin: | 1 | 2 | 3 | 4 | 5 | 6 | 7 | 8 | PH ¹⁾ |

| Output circuit | Type of connection | M12 connector, 5-pin | | | | | | |
|-----------------------------|--------------------|----------------------|-----|----|---|---|---|------------------|
| 7, 8 without inv. signal | 4 | Signal: | 0 V | +V | A | B | 0 | \perp |
| | | Pin: | 1 | 2 | 3 | 4 | 5 | PH ¹⁾ |

- +V: Supply voltage encoder +V DC
- 0 V: Supply voltage encoder ground GND (0 V)
- A, \bar{A} : Incremental output channel A
- B, \bar{B} : Incremental output channel B
- 0, $\bar{0}$: Reference signal

Output signal formats

All Kübler encoders come standard with six channels where A leads B in the clockwise direction and the standard index is gated with A & B. The tolerance of the wave form affects the control and, in some cases, may affect the smoothness of system operation.

| A leads B | | |
|---|---|--|
| when the shaft is rotated in the clockwise direction viewing the shaft or collet end. This is the Kübler standard. This format applies to the pin key codes listed below. | | |
| Order code | | |
| 1 | | |
| standard | 0 gated with A & B. This is the Kübler standard. 0 is 90° wide. | |
| P03 | 0 ungated. 0 is 330° to 360° wide. | |

Signal tolerances

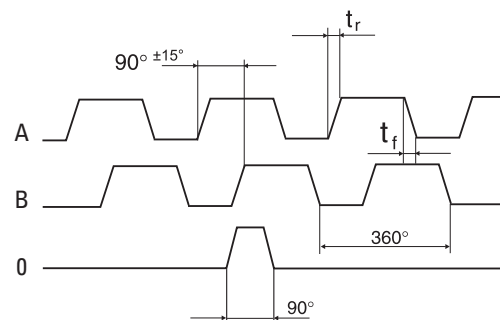

t_r = rising edge time
 t_f = falling edge time

1) PH = shield is attached to connector housing.

Incremental encoders

Compact optical **Sendix Base KIS40 / KIH40 (shaft / hollow shaft)** **Push-pull / RS422 / Open collector**

Dimensions shaft version

Dimensions in mm [inch]

Clamping-synchro flange, ø 40 [1.57]

Flange type 1

- 1 3 x M3, 4 [0.16] deep
- 2 4 x M3, 4 [0.16] deep

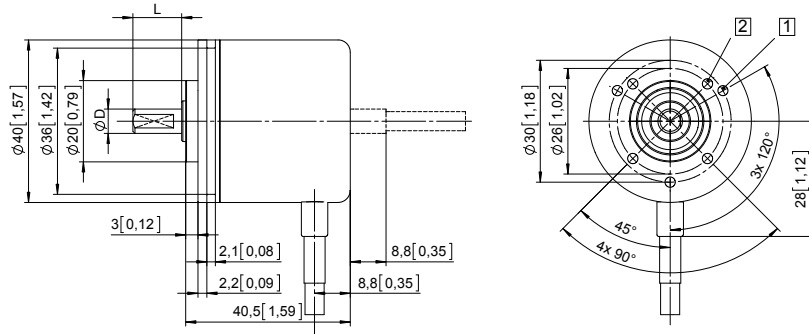

| D | Fit | L |
|----------|-----|-------------|
| 6 [0.24] | h7 | 12.5 [0.49] |
| 1/4" | h7 | 12.5 [0.49] |
| 8 [0.32] | h7 | 12.5 [0.49] |

Dimensions hollow shaft version

Dimensions in mm [inch]

Flange with spring element, long

Flange type 2

- 1 M2,5, 4 [0.16] deep

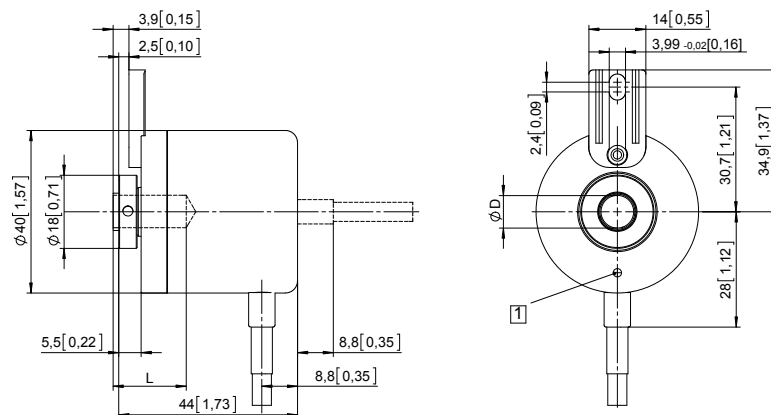

| D | Fit | L |
|----------|-----|-----------|
| 6 [0.24] | H7 | 18 [0.71] |
| 8 [0.32] | H7 | 18 [0.71] |
| 1/4" | H7 | 18 [0.71] |

L = insertion depth max. blind hollow shaft
insertion depth min. = 15 mm [0.59]

Flange with stator coupling, ø 46 [1.81]

Flange type 5

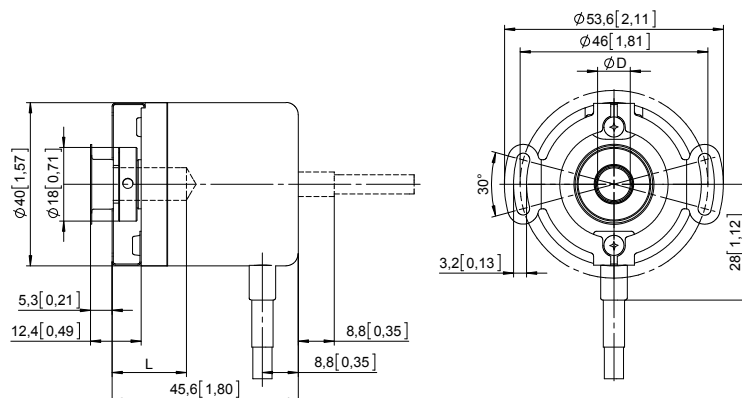

| D | Fit | L |
|----------|-----|-----------|
| 6 [0.24] | H7 | 18 [0.71] |
| 8 [0.32] | H7 | 18 [0.71] |
| 1/4" | H7 | 18 [0.71] |

L = insertion depth max. blind hollow shaft
insertion depth min. = 15 mm [0.59]