



TAI-SAW TECHNOLOGY CO., LTD.

No. 3, Industrial 2nd Rd., Ping-Chen Industrial District,
Taoyuan, 324, Taiwan, R.O.C.

TEL: 886-3-4690038 FAX: 886-3-4697532

E-mail: tstsales@mail.taisaw.com Web: www.taisaw.com

Product Specifications Approval Sheet

Product Description: SAW Rx Filter 942.5MHz LTE Band 8 SMD 1109

TST Part No.: TA1839C

Customer Part No.: _____

Customer signature required
Company: _____
Division: _____
Approved by : _____
Date: _____

Checked by: _____ Hayley Chou *Hayley Chou*

Approved by: _____ Andy Yu *Andy Yu*

Date: _____ 2017, 04. 05

1. Customer signed back is required before TST can proceed with sample build and receive orders.
2. Orders received without customer signed back will be regarded as agreement on the specifications.
3. Any specifications changes must be approved upon by both parties and a new revision of specifications shall be released to reflect the changes.



TAI-SAW TECHNOLOGY CO., LTD.

No. 3, Industrial 2nd Rd., Ping-Chen Industrial District,
Taoyuan, 324, Taiwan, R.O.C.

TEL: 886-3-4690038 FAX: 886-3-4697532

E-mail: tstsales@mail.taisaw.com Web: www.taisaw.com

SAW Rx Filter 942.5MHz LTE Band 8 SMD 1109 (35MHz BW)

MODEL NO.: TA1839C

REV. NO.:2

A. MAXIMUM RATING:

1. Maximum input power: +10 dBm (In Passband)
2. Maximum DC Voltage : +/-5 V (Device only)
3. Operating temperature: -20 °C to +85 °C
4. Device storage temperature: -40 °C to +100 °C
5. Moisture Sensitive Level: Level 1
6. ESD 100V(MM) 200V(HBM)

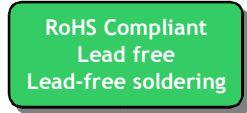

Electrostatic Sensitive Device (ESD)

B. ELECTRICAL CHARACTERISTICS:

Terminating source impedance: $Z_s = 50 \Omega$ (Single-ended)

Terminating load impedance: $Z_L = 50 \Omega$ (Single-ended)

Parameters Description		Unit	Min.	Typ.	Max.	Remark
Center Frequency		MHz	-	942.5	-	
Insertion Loss(*1)	925~960 MHz	dB	-	2.0	3.0	
Amplitude Ripple	925~960 MHz	dB	-	1.3	2.3	
VSWR	Input	925~960 MHz	-	1.9	2.3	
	Output	925~960 MHz	-	2.0	2.3	
Attenuation:						
880~915 MHz		dB	46	48	-	
980~1558 MHz		dB	15	26	-	
1559~1607 MHz		dB	40	51	-	
1850~1920 MHz		dB	35	44	-	
2400`2500 MHz		dB	30	38	-	
2775~2880 MHz		dB	28	36	-	
3700~3840 MHz		dB	25	32	-	
4625~4800 MHz		dB	20	30	-	
4900~5950 MHz		dB	18	27	-	
5550~5725 MHz		dB	18	27	-	
6475~6720 MHz		dB	15	25	-	
7400~7680 MHz		dB	15	23	-	

(*1) Specification of insertion loss excludes loss that comes from the test board.

C. FREQUENCY CHARACTERISTICS:

Frequency Response

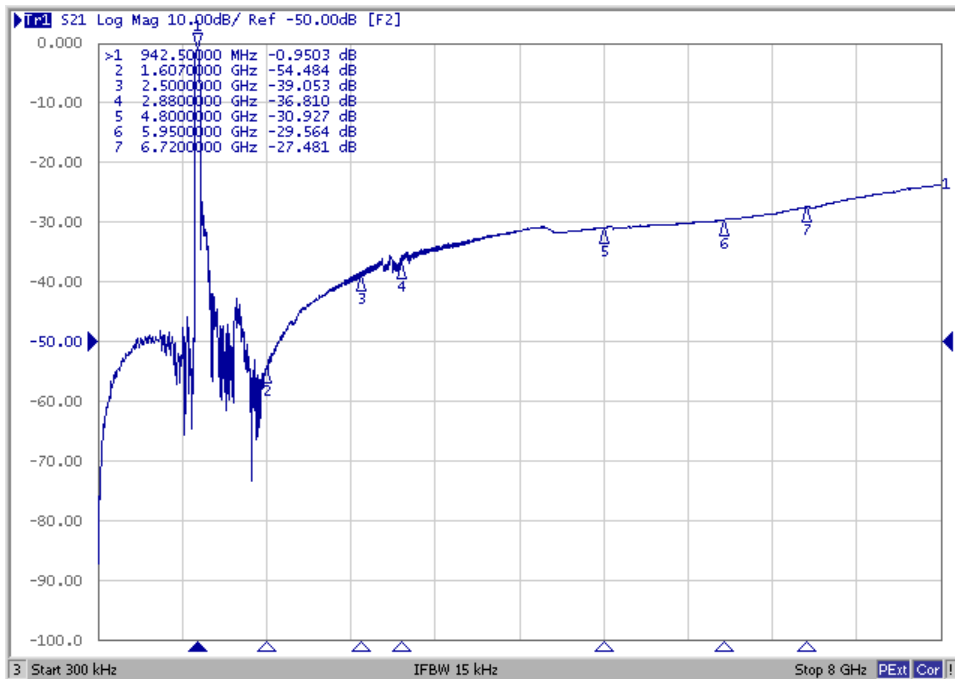
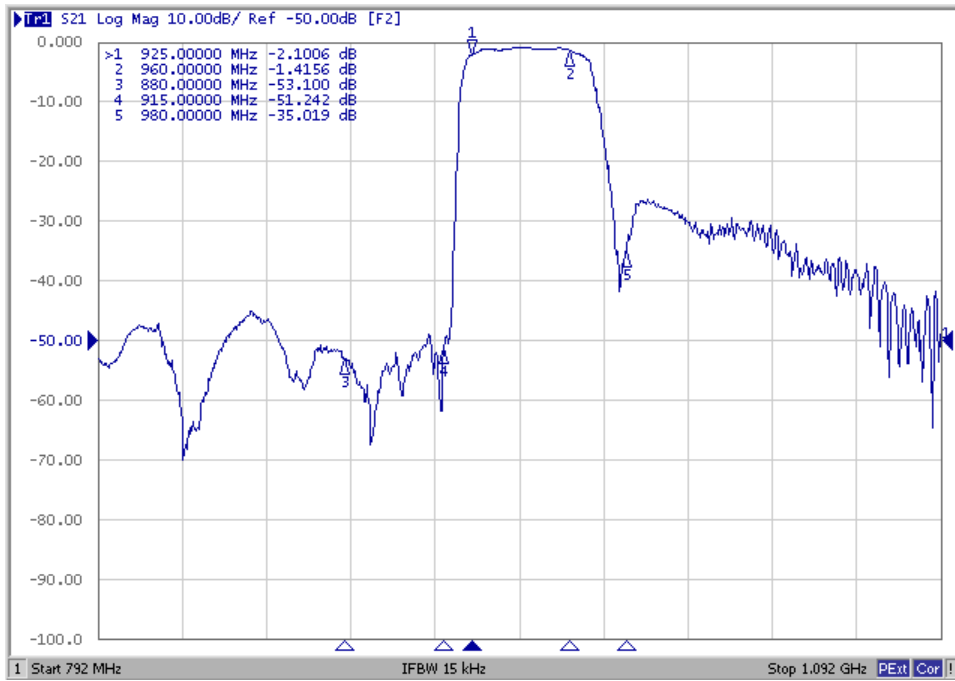

Ripple

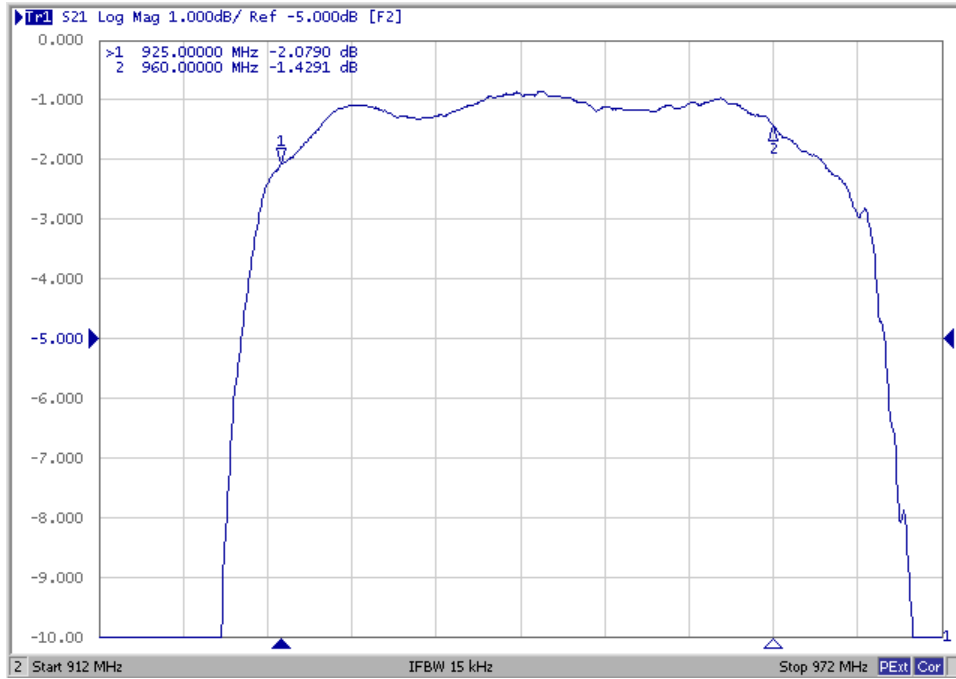

VSWR

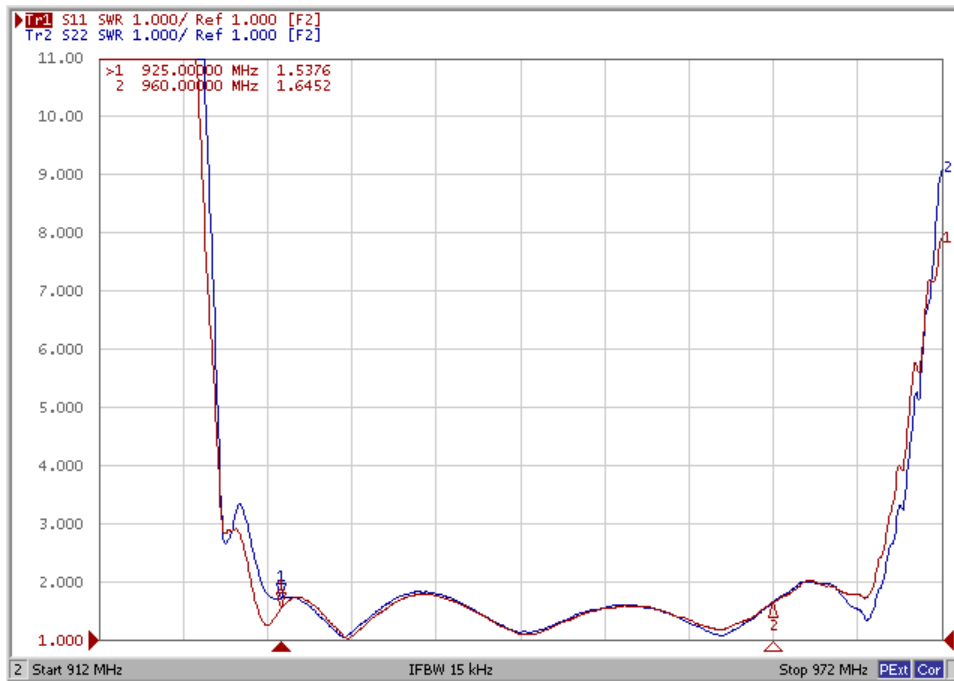

S11

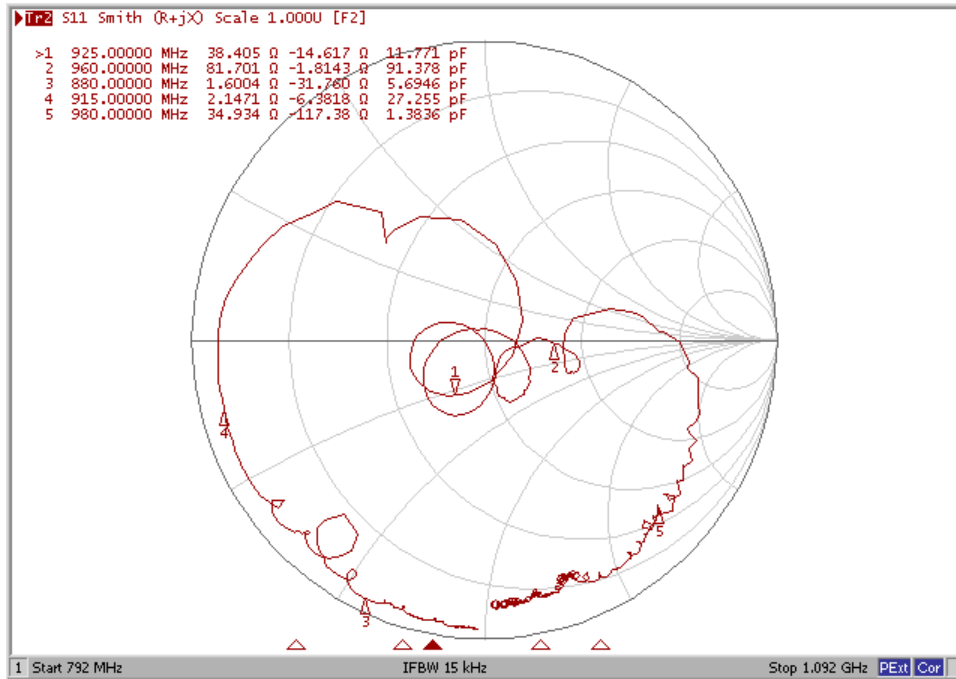

S22

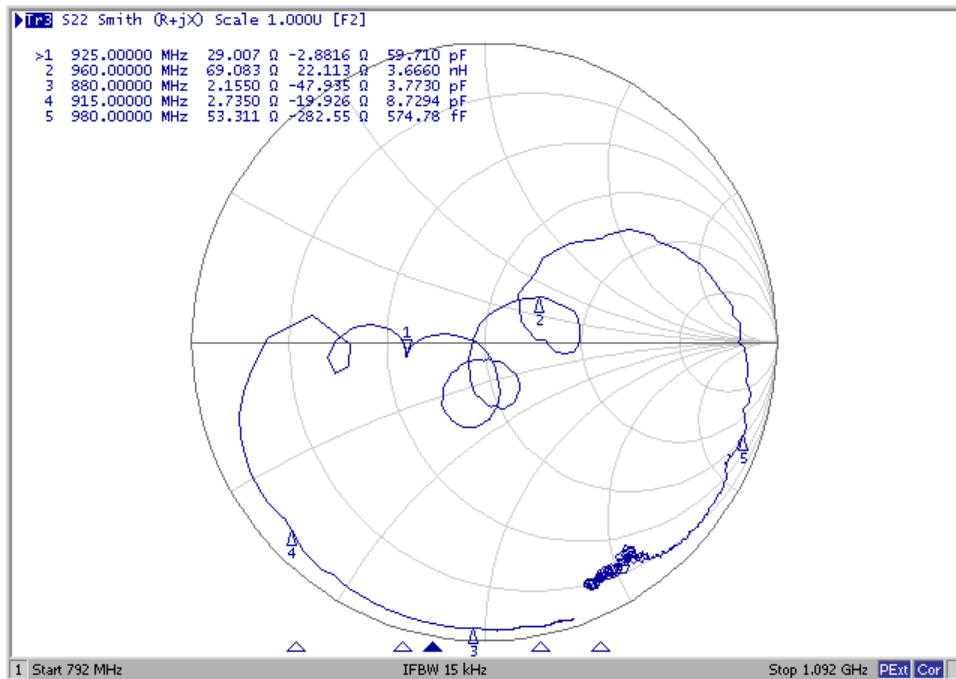

D. MEASUREMENT CIRCUIT:

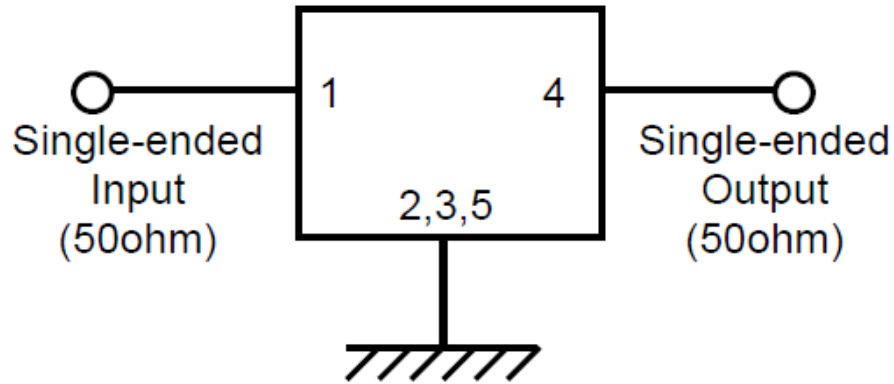

E. OUTLINE DRAWING:

Device size: 1.1typ. x 0.9typ. x 0.5max

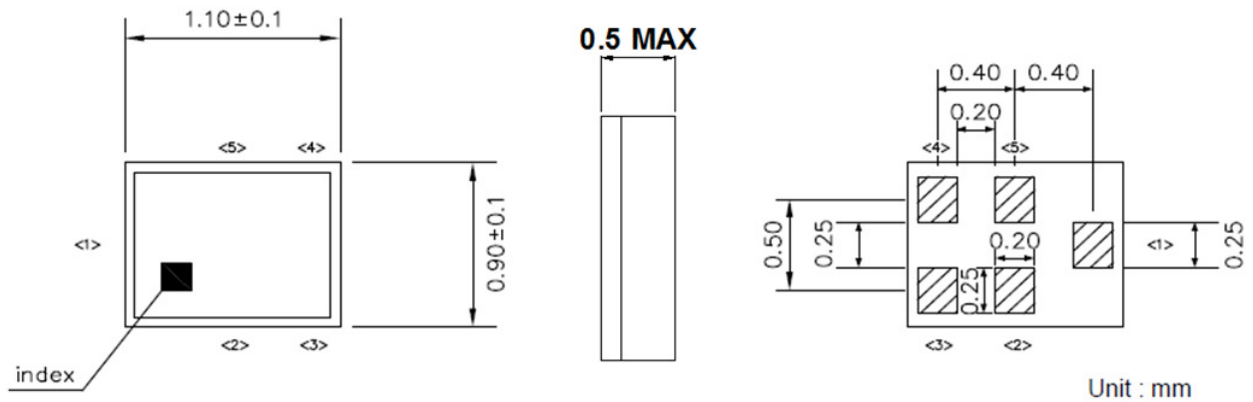

Pin Configuration

Pin No.	Symbol	Function
1	IN	Single-ended pin
2	GND	Ground
3	GND	Ground
4	OUT	Single-ended pin
5	GND	Ground

Top View (Sample Production):

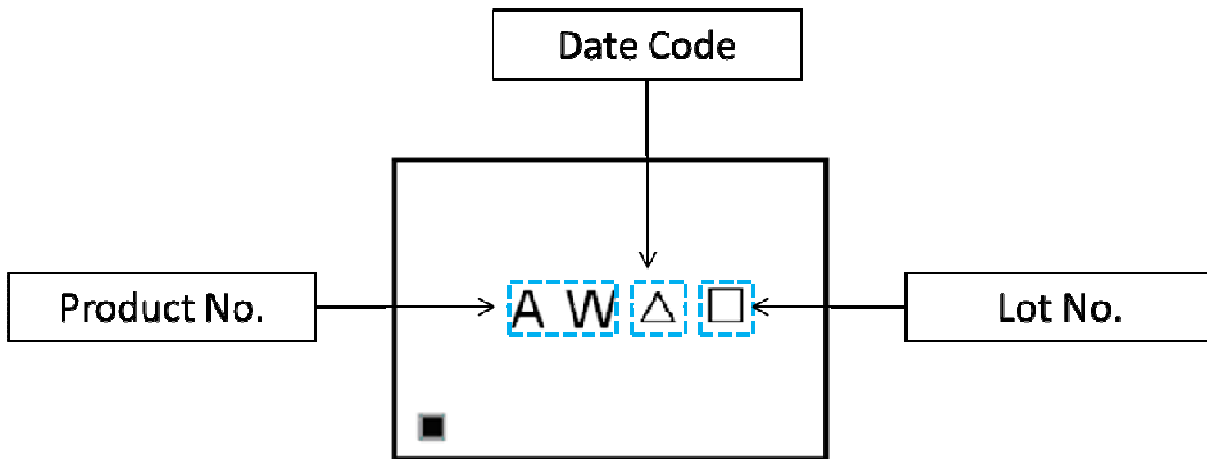

Top View (Mass Production):

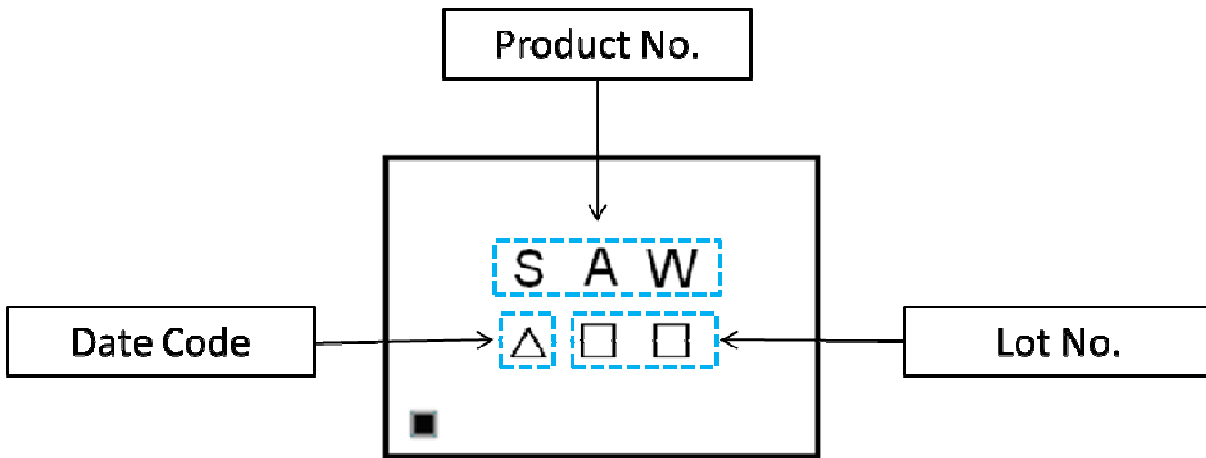

△ : Date Code

□ : Lot No. (Indicated by 0~9 or A to Z and a to z, except I, O, i, o and l)

Product date Code (EIAJ)

Year	Jan	Feb	Mar	Apr	May	Jun	Jul	Aug	Sep	Oct	Nov	Dec
2015	a	b	c	d	e	f	g	h	j	k	l	m
2016	n	p	q	r	s	t	u	v	w	x	y	z
2017	A	B	C	D	E	F	G	H	J	K	L	M
2018	N	P	Q	R	S	T	U	V	W	X	Y	Z

F. PACKING:

1. REEL DIMENSION

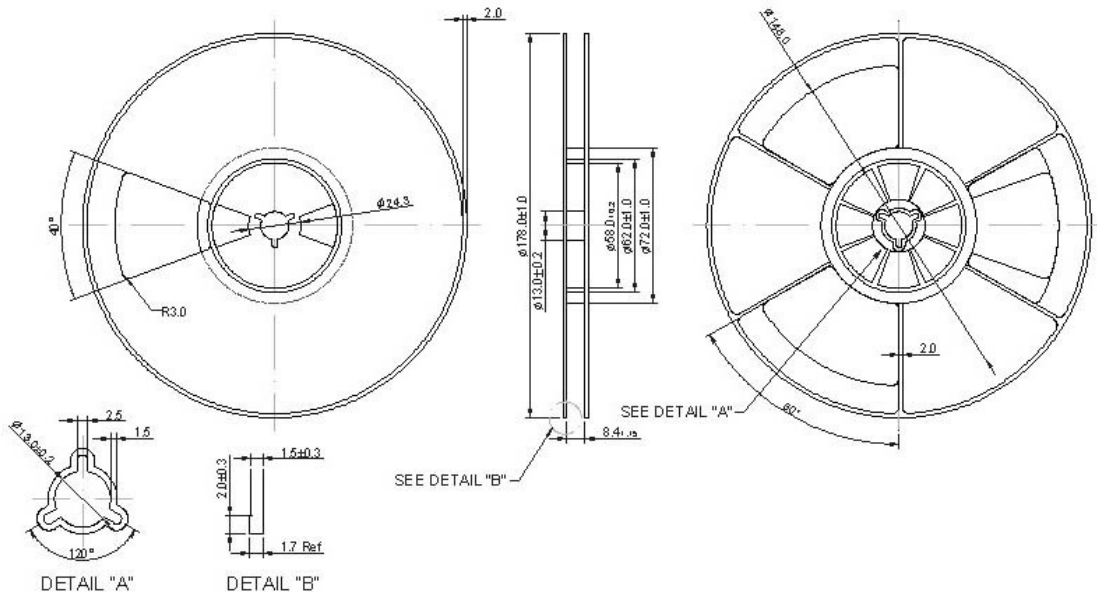

2. TAPE DIMENSION

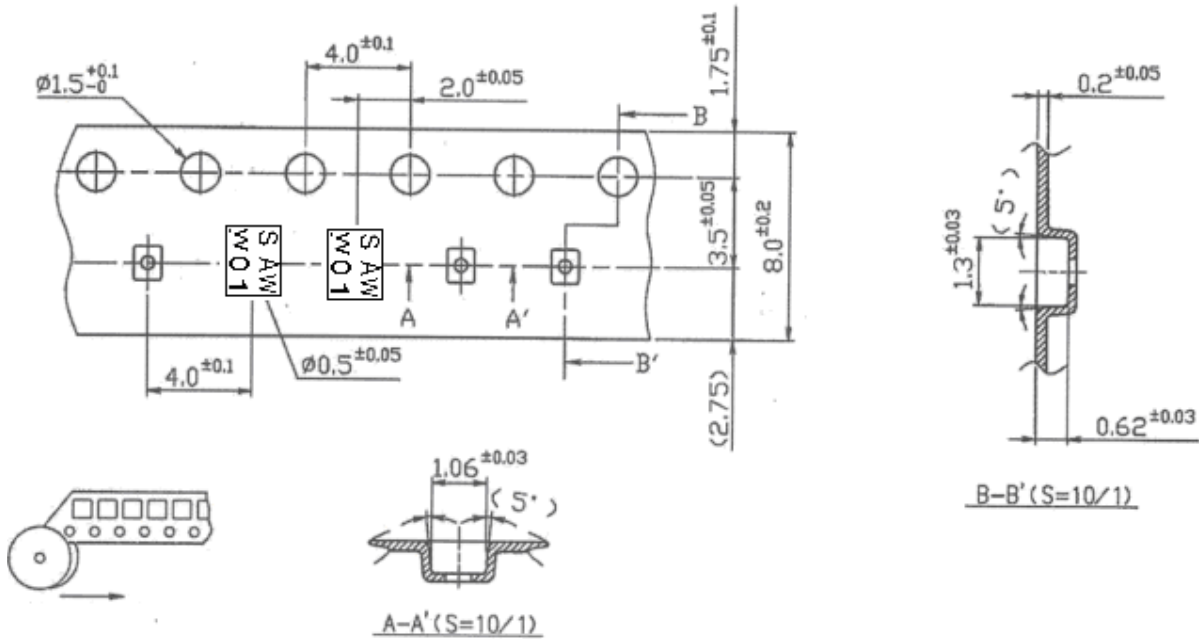

G. RECOMMENDED REFLOW PROFILE:

1. Preheating shall be fixed at 150~180°C for 60~90 seconds.
2. Ascending time to preheating temperature 150°C shall be 30 seconds min.
3. Heating shall be fixed at 220°C for 50~80 seconds and at 260°C+0/-5°C peak (20~40sec).
4. Time: 2 times.

