

LOC		DIST		REVISIONS			
P	LTN	DESCRIPTION	DATE	DWN	APVD		
A		RELEASE	01NOV2016	JY	SH		
B		REVISED PER ECO-17-011899	15AUG2017	RG	SH		
C		ADD SOME DIMENSIONS	10JAN2018	JY	SH		
D		REVISED PER ECO-19-013580	04SEP2019	SH	SH		

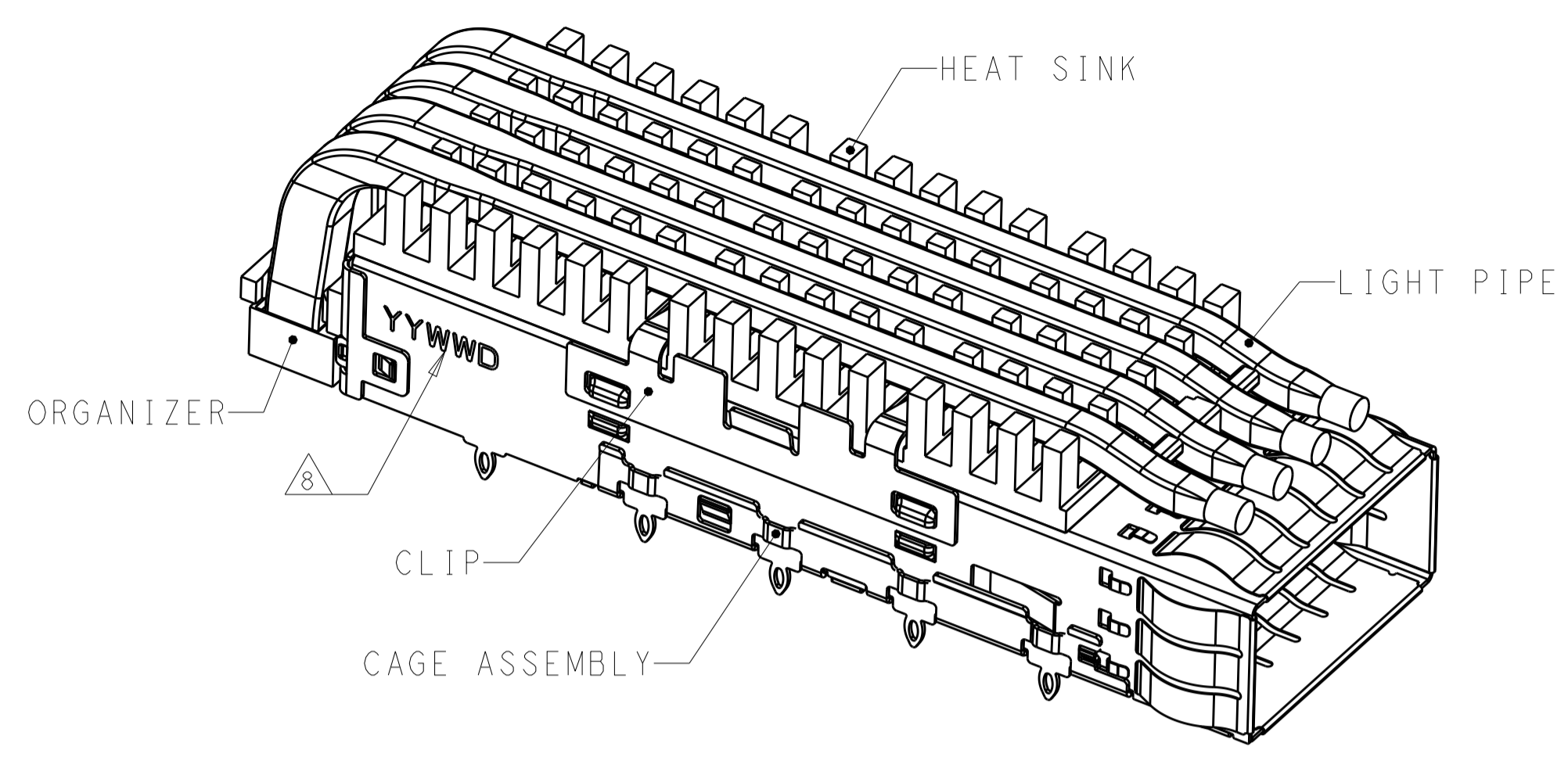

4-2170705-2 SHOWN
SCALE 3:1

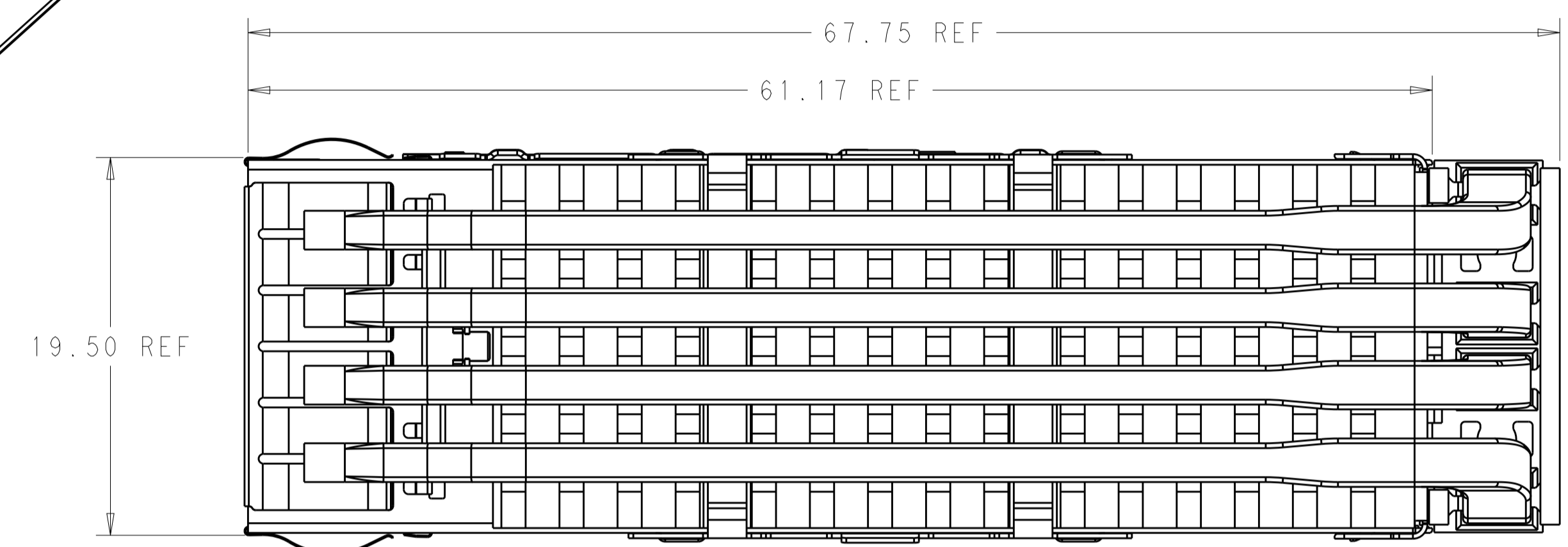

- MATERIAL: CAGE MATERIAL : 0.25 THICK NICKEL SILVER.
 SPRING MATERIAL: COPPER ALLOY
 HEAT SINK MATERIAL: ALUMINUM
 CLIP MATERIAL: STAINLESS STEEL
 LIGHT PIPE MATERIAL: POLYCARBONATE
 ORGANIZER MATERIAL: POLYESTER
- FINISH: SPRING: NICKEL PLATING
 HEAT SINK: BLACK ANODIZE

- ⚠ DIMENSION APPLIES WITH MODULE INSTALLED IN THE CAGE TO TOP OF HEAT SINK.
- ⚠ REFERENCE APPLICATION SPEC 114-32023 FOR RECOMMENDED DRILL HOLE DIAMETER AND PLATING THICKNESS.
- ⚠ DATUM AND BASIC DIMENSIONS ESTABLISHED BY CUSTOMERS.
- 6. MINIMUM PC BOARD THICKNESS : SINGLES SIDED: 1.57 MIN
 DOUBLE SIDED: 2.20 MIN
- ⚠ DATUM [-A-] IS TOP SURFACE OF THE HOST BOARD.
- ⚠ DATE CODE (YYWWD) MARKED APPROXIMATELY AS SHOWN
- ⚠ THESE HOLES ARE OPTIONAL WHEN THE REAR PINS ARE REMOVED.
- 10. MATES WITH QSFP28 MSA COMPATIBLE TRANSCEIVER.
- ⚠ PRELIMINARY PART - NOT RELEASE TO PRODUCTION.

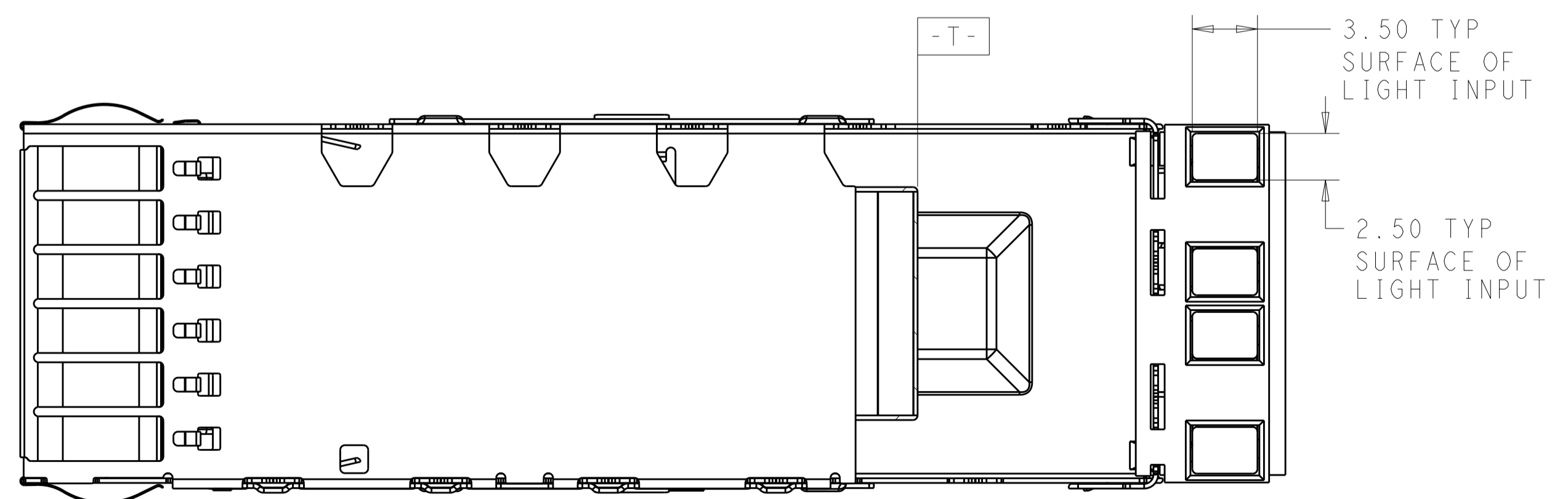
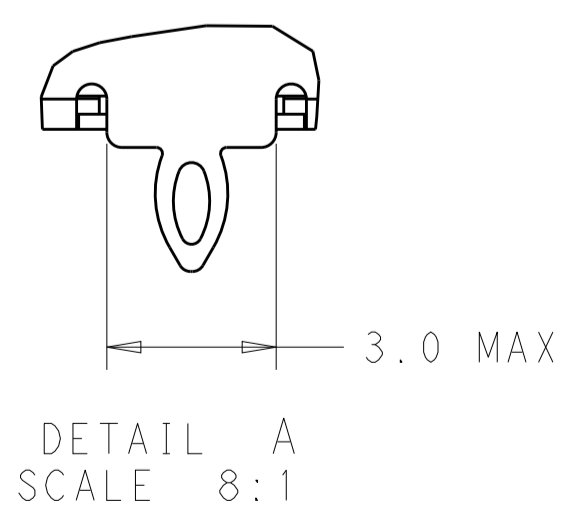
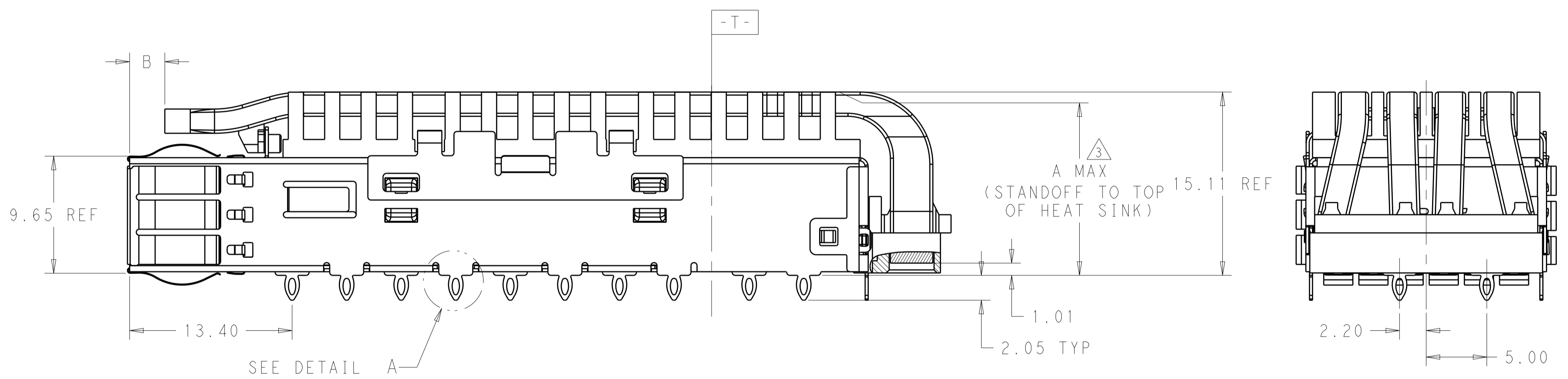
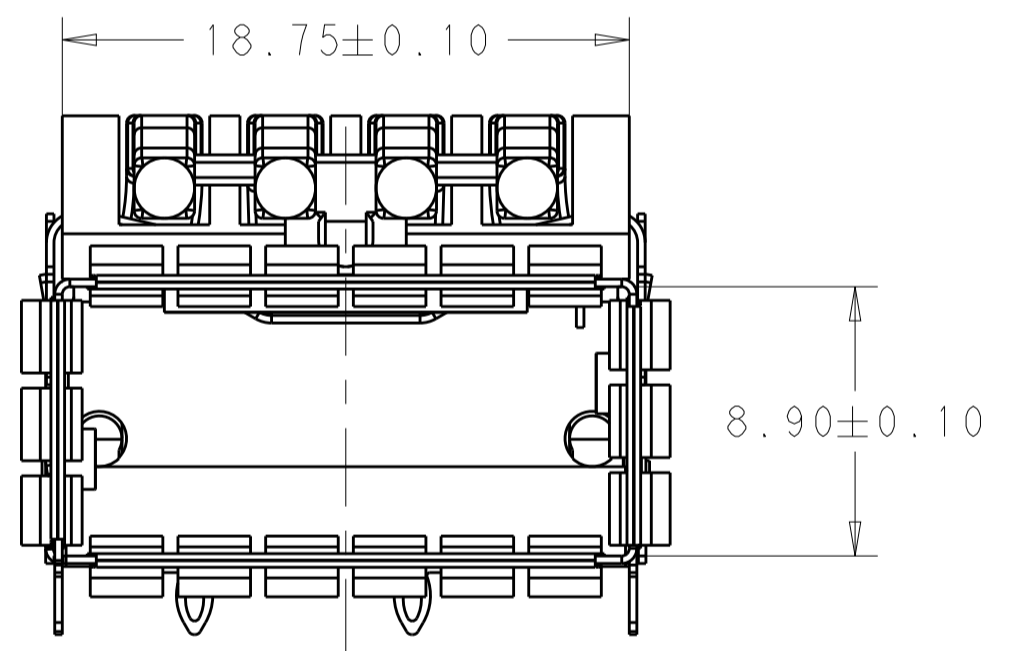

4-2170705-2 AS SHOWN

THIS DRAWING IS A CONTROLLED DOCUMENT.		DWN: JASON YANG 07MAR2014	TE Connectivity
DIMENSIONS: mm		CHK: SEAN HAN 26JAN2016	
TOLERANCES UNLESS OTHERWISE SPECIFIED:		APVD:	NAME: CAGE ASSEMBLY, QSFP28, THRU BEZEL WITH EMI SPRING FINGER HEAT SINK, LIGHT PIPE
0 PLC ±0.25		PRODUCT SPEC: 108-19428	SIZE: CAGE CODE DRAWING NO: A100779C=2170705
1 PLC ±0.25		APPLICATION SPEC: 114-32023	RESTRICTED TO: -
2 PLC ±0.20		WEIGHT: -	SCALE: 2:1 SHEET 1 OF 7 REV D
3 PLC ±0.100		CUSTOMER DRAWING	
4 PLC ±			
ANGLES °			
FINISH			

LOC		DIST		REVISIONS			
				REV	DATE	BY	APPV

HEAT SINK OPTIONS

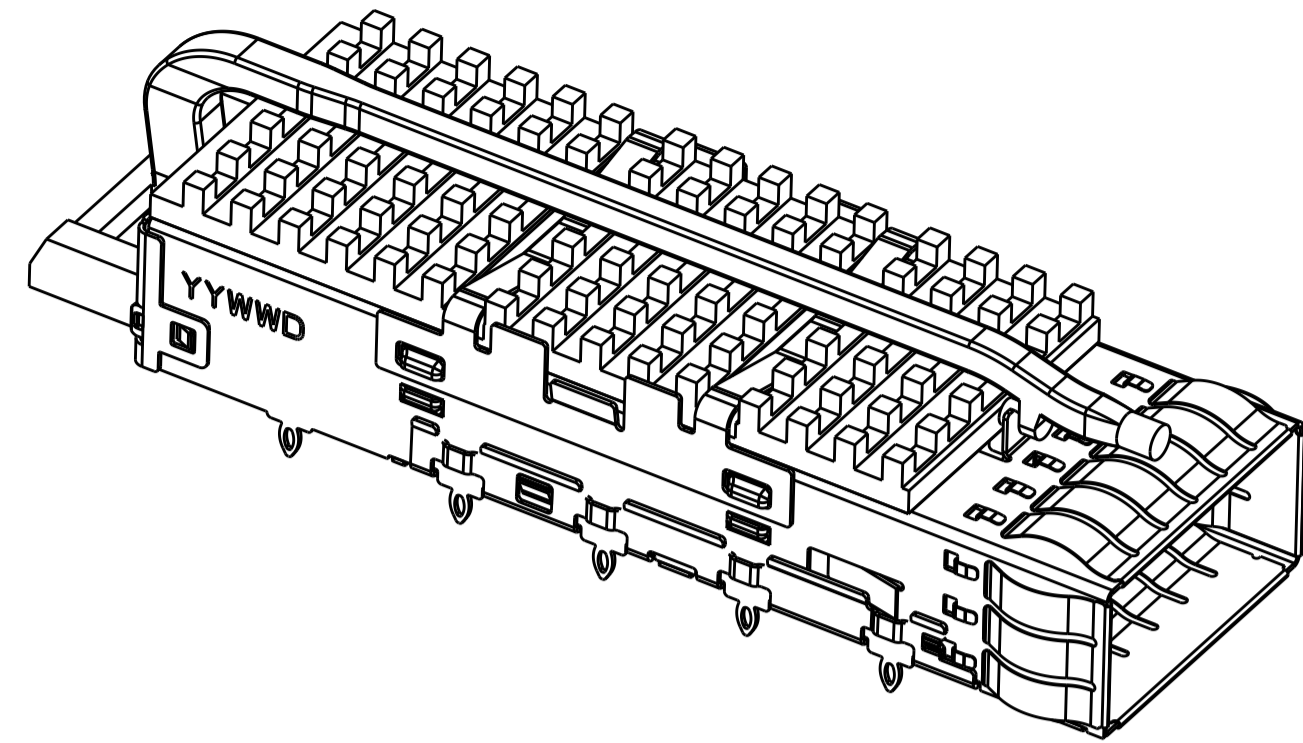

PCI HEAT SINK
SCALE 5:2

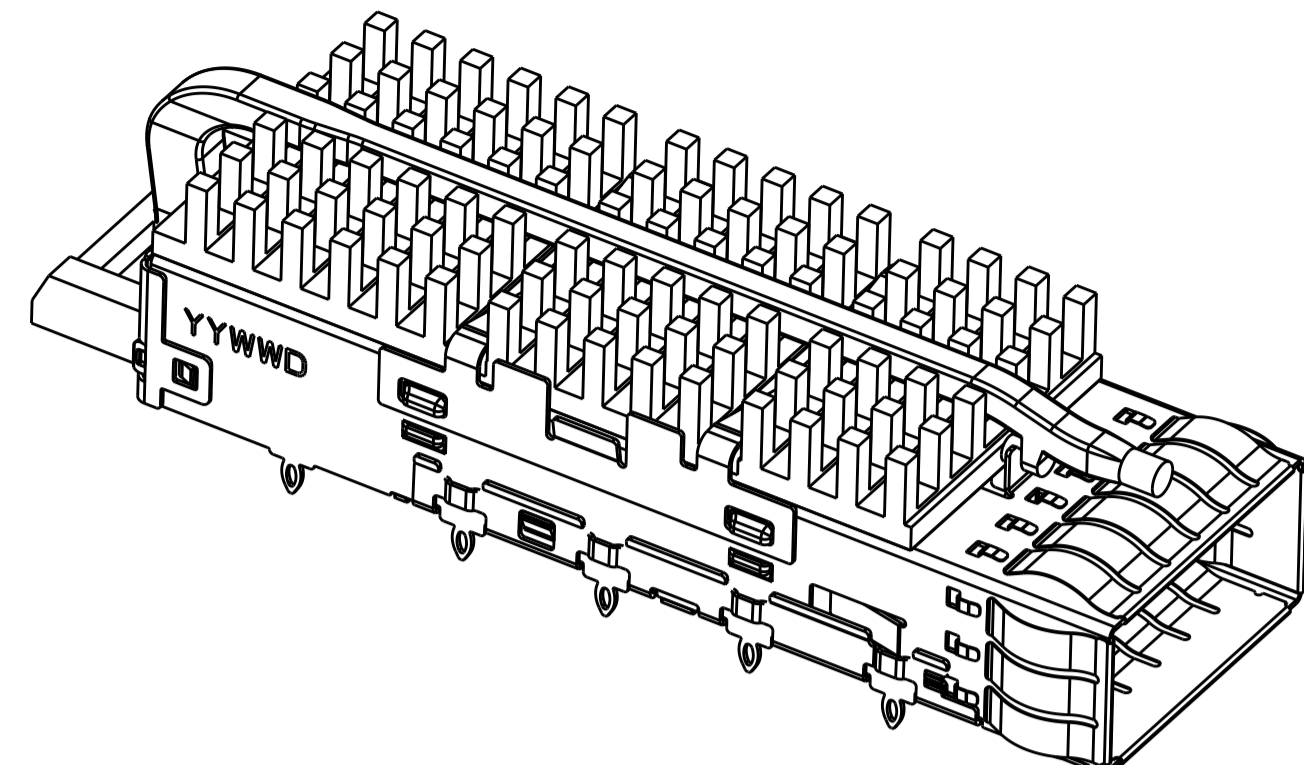

SAN HEAT SINK
SCALE 5:2

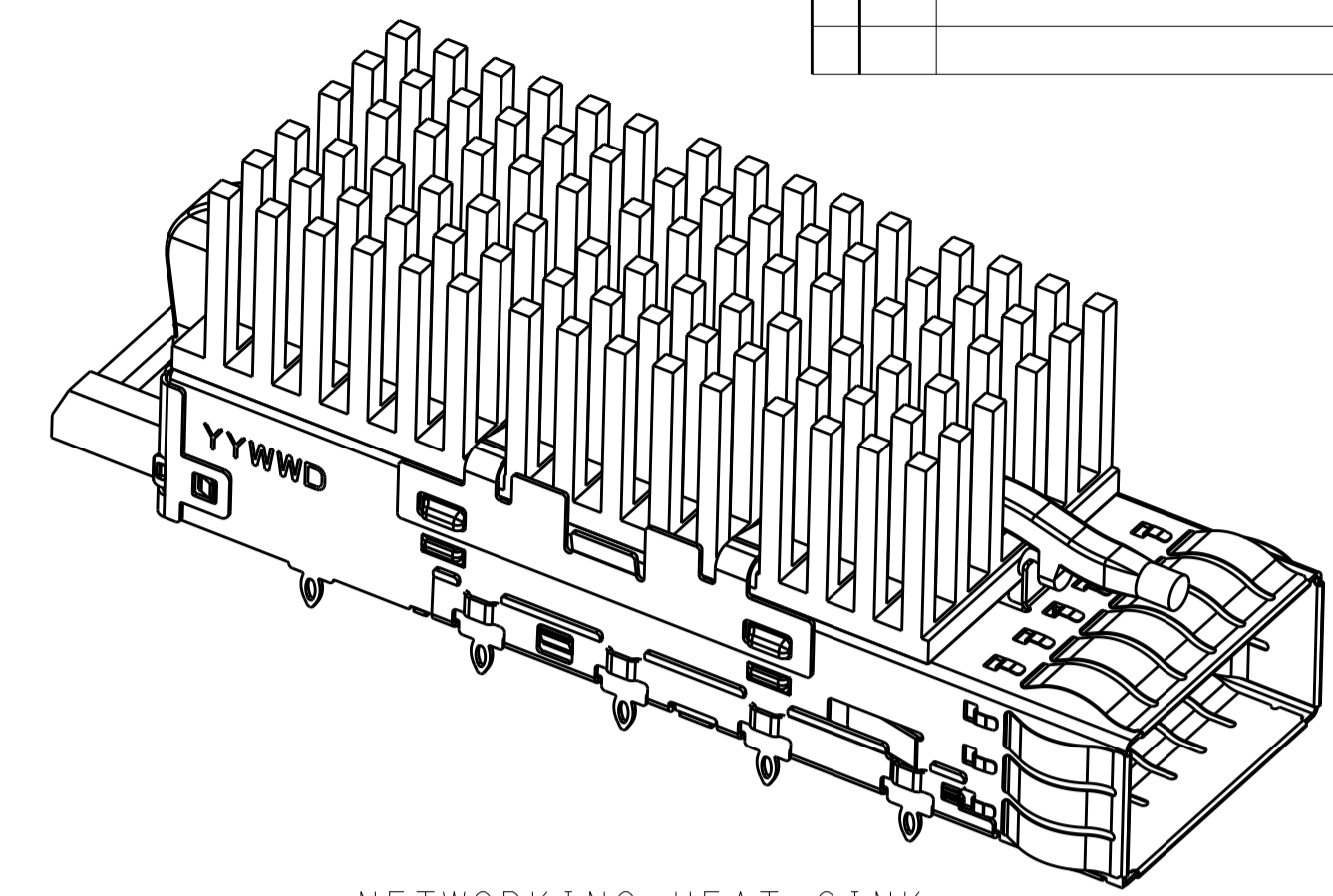

NETWORKING HEAT SINK
SCALE 5:2

OF REAR LEGS OPTIONS

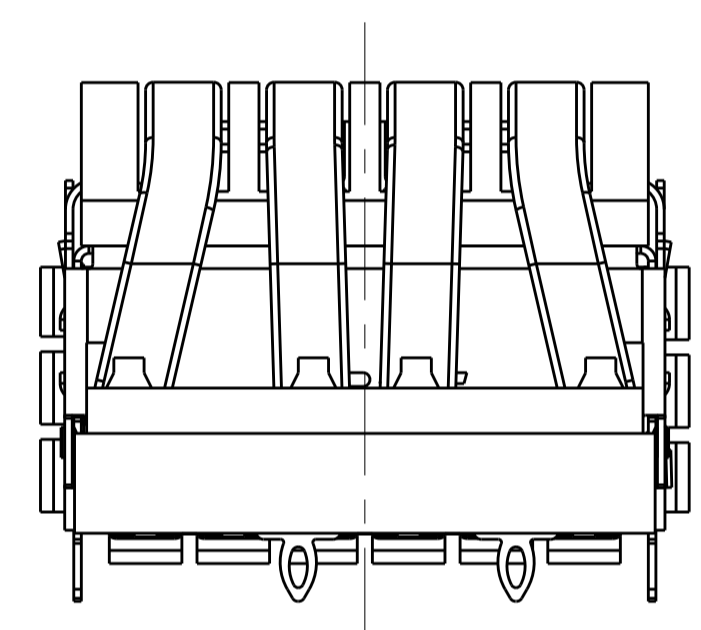

2 REAR LEGS
SCALE 4:1

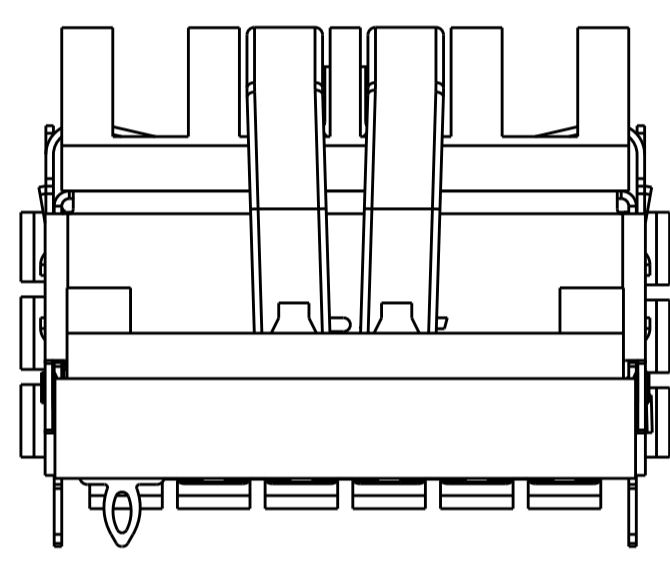

1 REAR LEG
SCALE 4:1

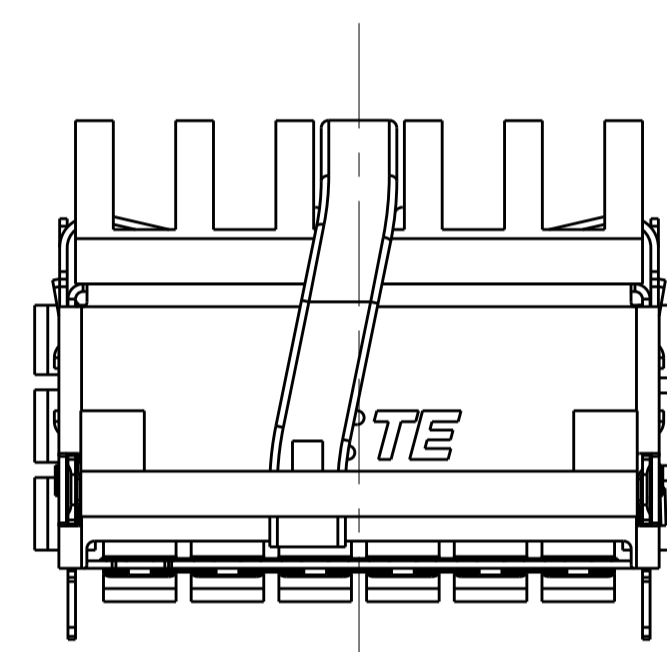

0 REAR LEG
SCALE 4:1

LIGHT PIPE OPTIONS

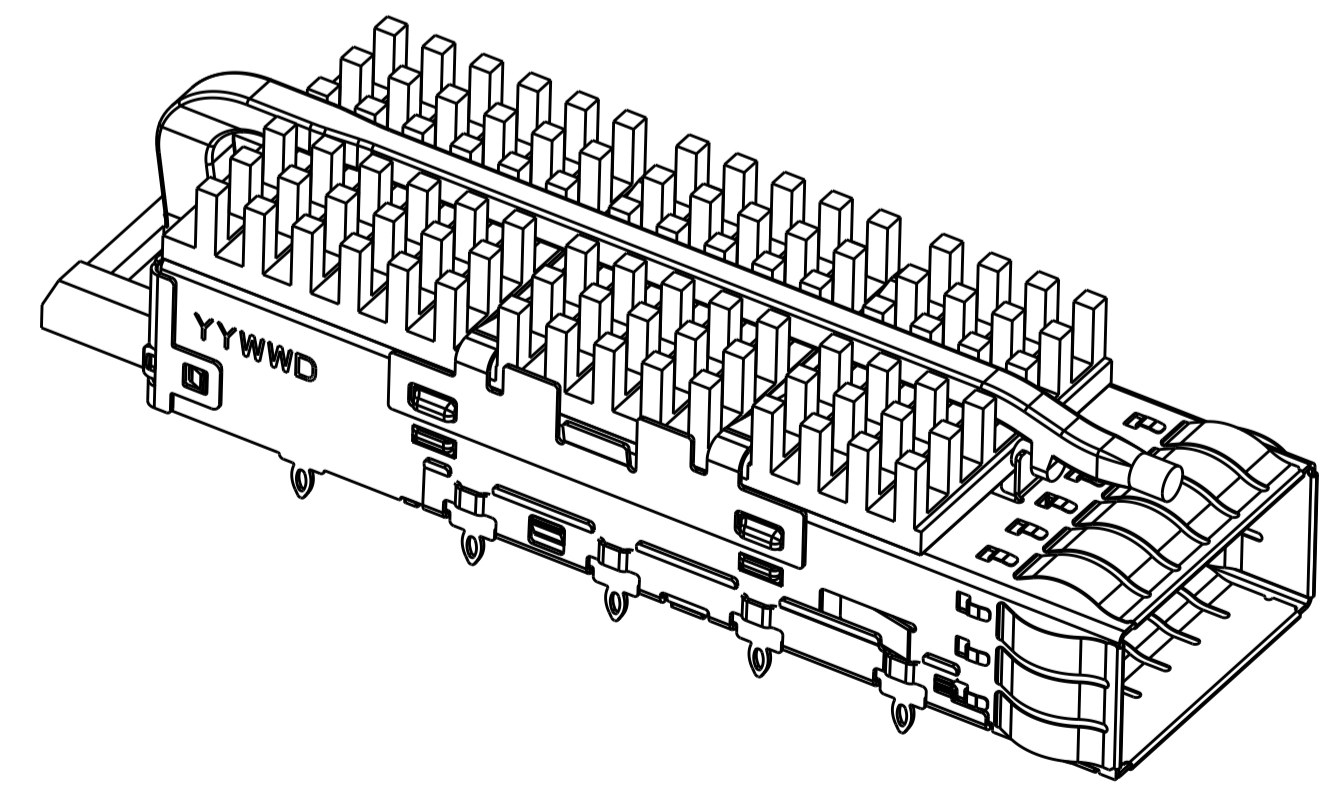

SINGLE LIGHT PIPE
WITHOUT ORGANIZER
SCALE 5:2

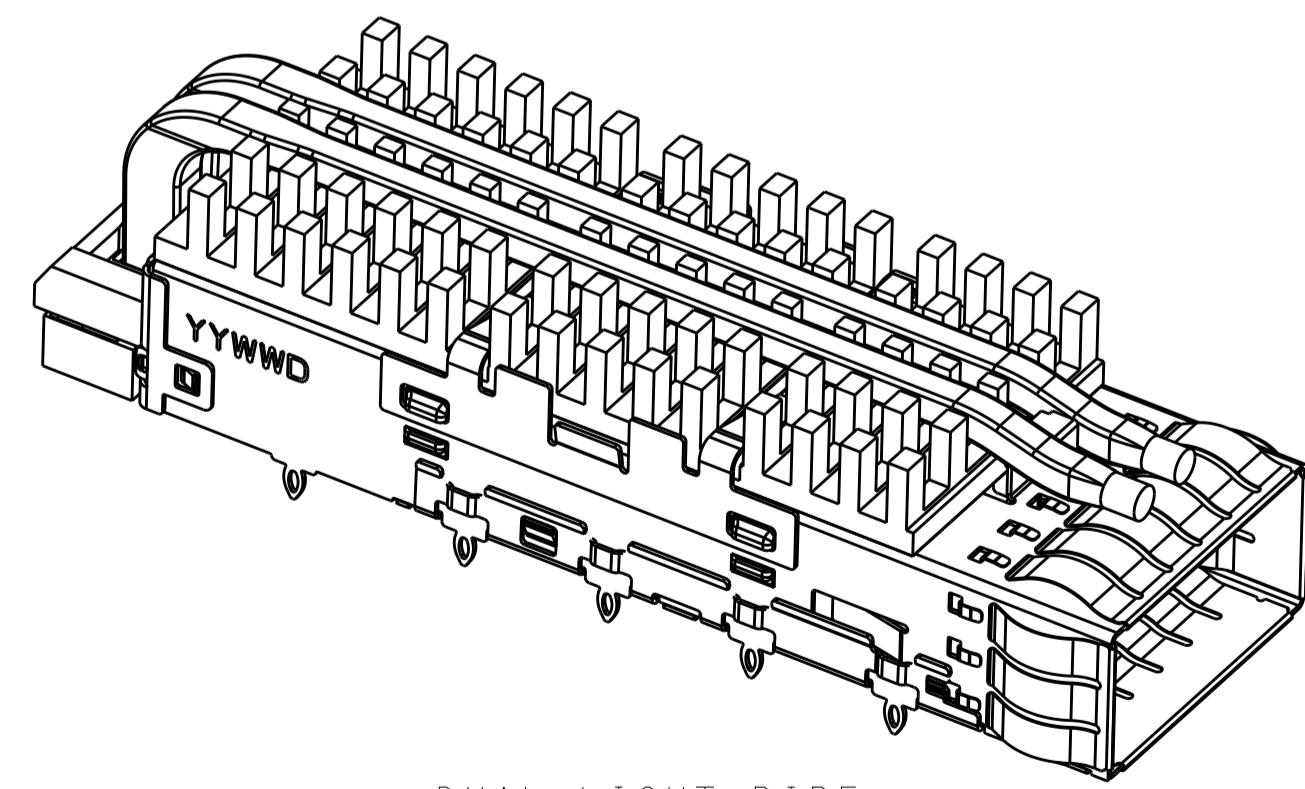

DUAL LIGHT PIPE
SCALE 5:2

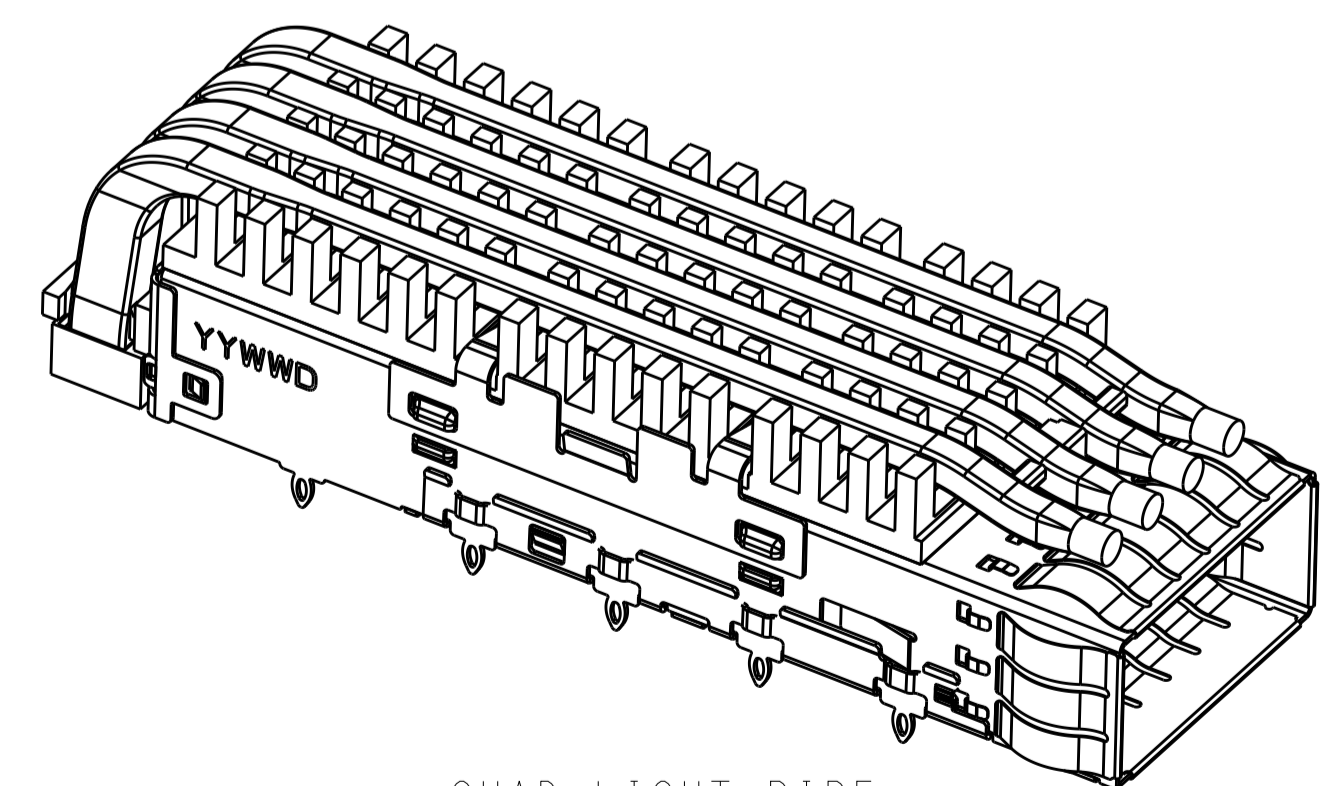

QUAD LIGHT PIPE
SCALE 5:2

THIS DRAWING IS A CONTROLLED DOCUMENT.		DWN: JASON YANG 07MAR2014	TE Connectivity
		CHK: SEAN HAN 26JAN2016	
DIMENSIONS:		NAME: CAGE ASSEMBLY, QSFP28, THRU BEZEL WITH EMI SPRING FINGER HEAT SINK, LIGHT PIPE	
mm		PRODUCT SPEC: 108-19428	
		APPLICATION SPEC: 114-32023	
TOLERANCES UNLESS OTHERWISE SPECIFIED:		SIZE: A100779C=2170705	
0 PLC ±0.25		RESTRICTED TO:	
1 PLC ±0.25		SCALE: 2:1 SHEET 2 OF 7 REV D	
2 PLC ±0.25			
3 PLC ±0.25			
4 PLC ±0.100			
ANGLES ±°			
FINISH:		CUSTOMER DRAWING	

LOC		DIST		REVISIONS			
P	LTN	DESCRIPTION	DATE	DWN	APVD		
-	-	SEE SHEET 1	-	-	-		

LIGHT PIPE LENGTH OPTIONS

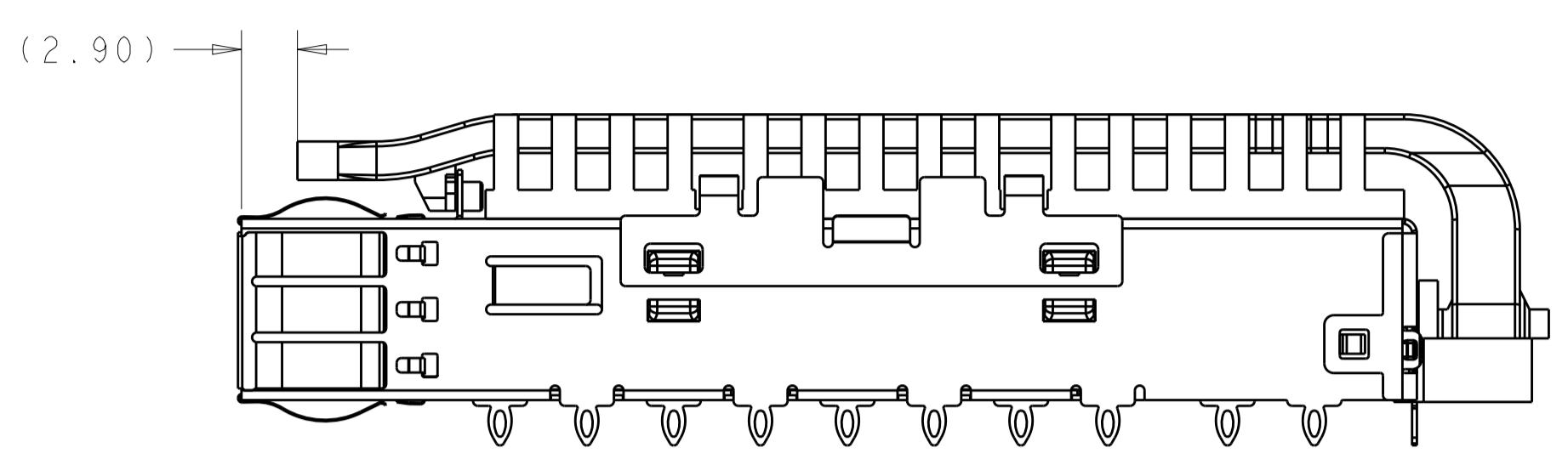

WITH LIGHT PIPE LENGTH B=2.9
SCALE 3:1

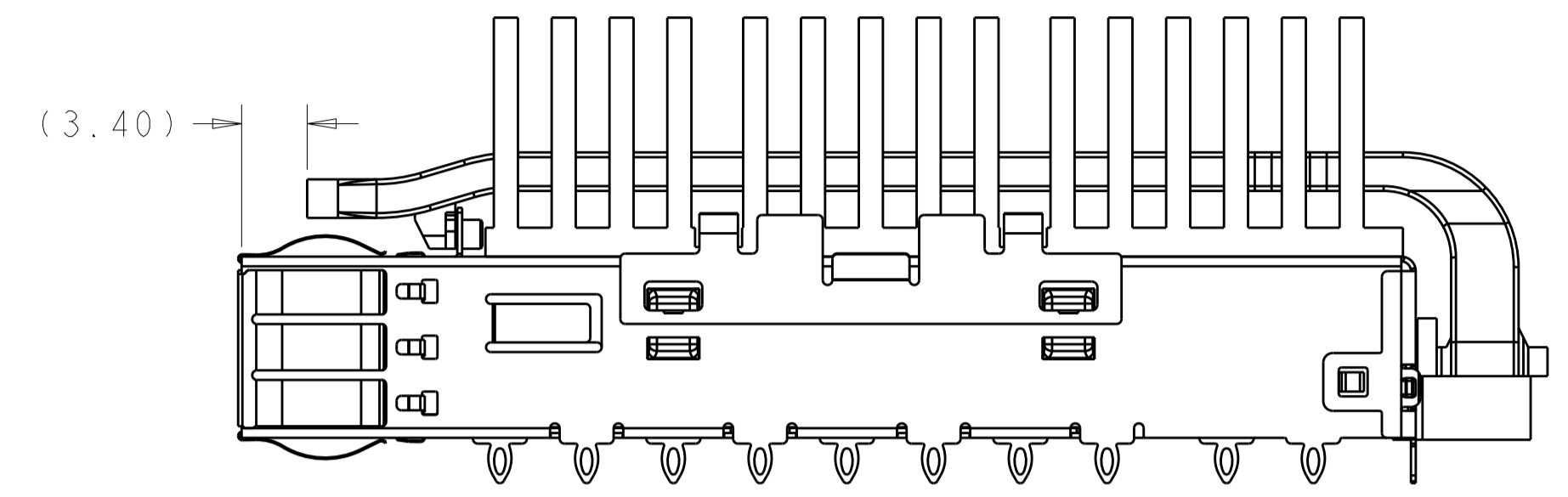

WITH LIGHT PIPE LENGTH B=3.4
SCALE 3:1

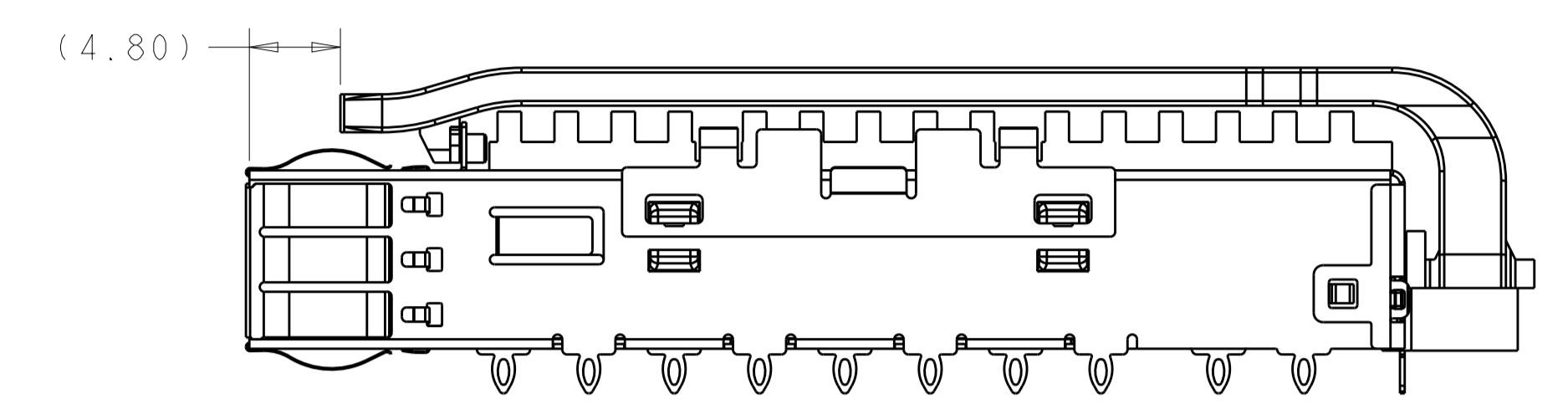

WITH LIGHT PIPE LENGTH B=4.8
SCALE 3:1

BOM

4.8	0	16.00	SAN	DUAL LP	6-2170705-3
5.2	1	16.00	SAN	DUAL LP	6-2170705-2
4.8	2	13.7	PCI	QUAD LP	6-2170705-1
3.4	1	23.0	NETWORKING	QUAD LP	5-2170705-9
2.9	1	16.0	SAN	COATED QUAD LP	5-2170705-8
	1	13.7	PCI	COATED QUAD LP	5-2170705-7
	0	31.6	CUSTOMIZED	QUAD LP	5-2170705-1
	1	23.0	NETWORKING	QUAD LP	4-2170705-9
	1	16.0	SAN	QUAD LP	4-2170705-8
	1	13.7	PCI	QUAD LP	4-2170705-7
	0	23.0	NETWORKING	QUAD LP	4-2170705-6
	0	16.0	SAN	QUAD LP	4-2170705-5
	0	13.7	PCI	QUAD LP	4-2170705-4
	2	23.0	NETWORKING	QUAD LP	4-2170705-3
	2	16.0	SAN	QUAD LP	4-2170705-2
	2	13.7	PCI	QUAD LP	4-2170705-1
	1	23.0	NETWORKING	DUAL LP	2-2170705-9
	1	16.0	SAN	DUAL LP	2-2170705-8
	1	13.7	PCI	DUAL LP	2-2170705-7
	0	23.0	NETWORKING	DUAL LP	2-2170705-6
	0	16.0	SAN	DUAL LP	2-2170705-5
	0	13.7	PCI	DUAL LP	2-2170705-4
	2	23.0	NETWORKING	DUAL LP	2-2170705-3
	2	16.0	SAN	DUAL LP	2-2170705-2
	2	13.7	PCI	DUAL LP	2-2170705-1
	1	23.0	NETWORKING	SINGLE LP(COATED)	1-2170705-0
	1	23.0	NETWORKING	SINGLE LP	2170705-9
	1	16.0	SAN	SINGLE LP	2170705-8
	1	13.7	PCI	SINGLE LP	2170705-7
	0	23.0	NETWORKING	SINGLE LP	2170705-6
	0	16.0	SAN	SINGLE LP	2170705-5
	0	13.7	PCI	SINGLE LP	2170705-4
2	23.0	NETWORKING	SINGLE LP	2170705-3	
2	16.0	SAN	SINGLE LP	2170705-2	
2	13.7	PCI	SINGLE LP	2170705-1	

DIM B	# REAR PINS	DIM A	APPLICATION (HEAT SINK OPTION)	LIGHT PIPE OPTION	PART NUMBER
-------	-------------	-------	--------------------------------	-------------------	-------------

THIS DRAWING IS A CONTROLLED DOCUMENT.		DWN: JASON YANG 07MAR2014	TE Connectivity
		CHK: SEAN HAN 26JAN2016	
DIMENSIONS:		APVD:	
mm	0 PLC ±0.25	PRODUCT SPEC	
	1 PLC ±0.25	108-19428	
	2 PLC ±0.25	APPLICATION SPEC	
	3 PLC ±0.100	114-32023	
	4 PLC ±"	CAGE CODE DRAWING NO	
	ANGLES	RESTRICTED TO	
MATERIAL	FINISH	WEIGHT	A100779C=2170705
CUSTOMER DRAWING		SCALE 2:1	SHEET 3 OF 7 REV D

LOC		DIST		REVISIONS			
P	LTN	DESCRIPTION	DATE	DMN	APVD		
-	-	SEE SHEET 1	-	-	-		

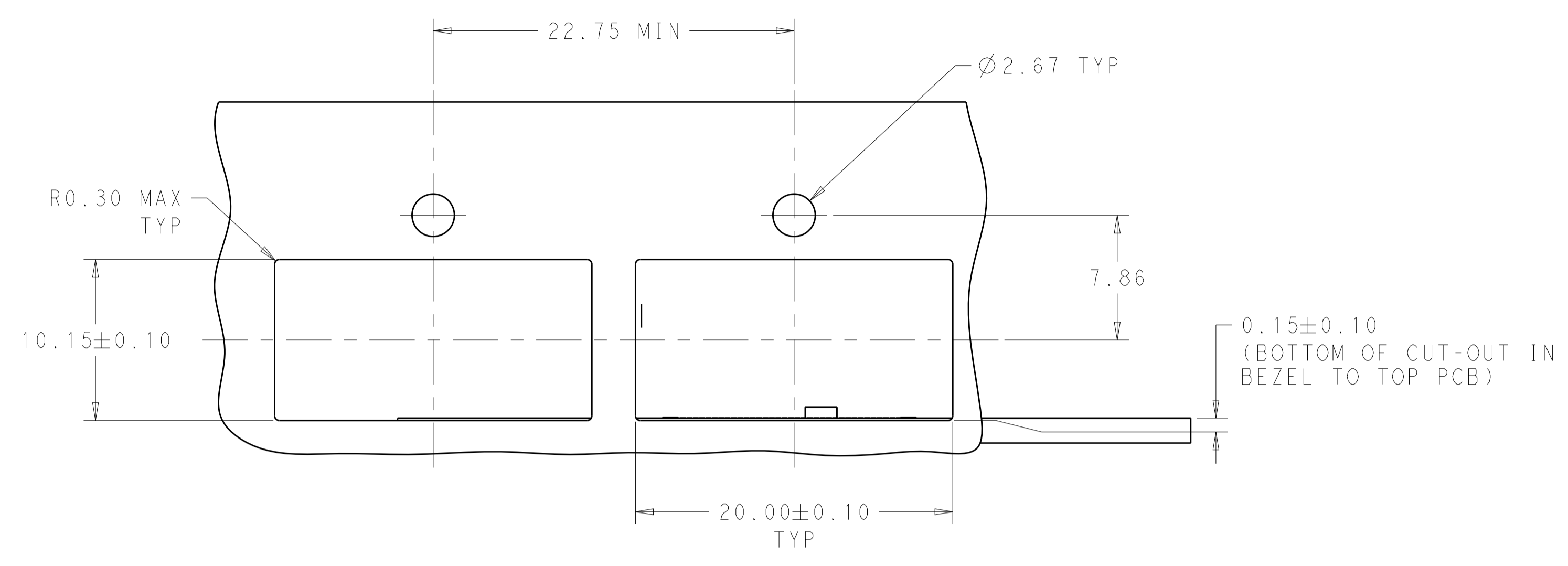

SINGLE LIGHT PIPE TYPE

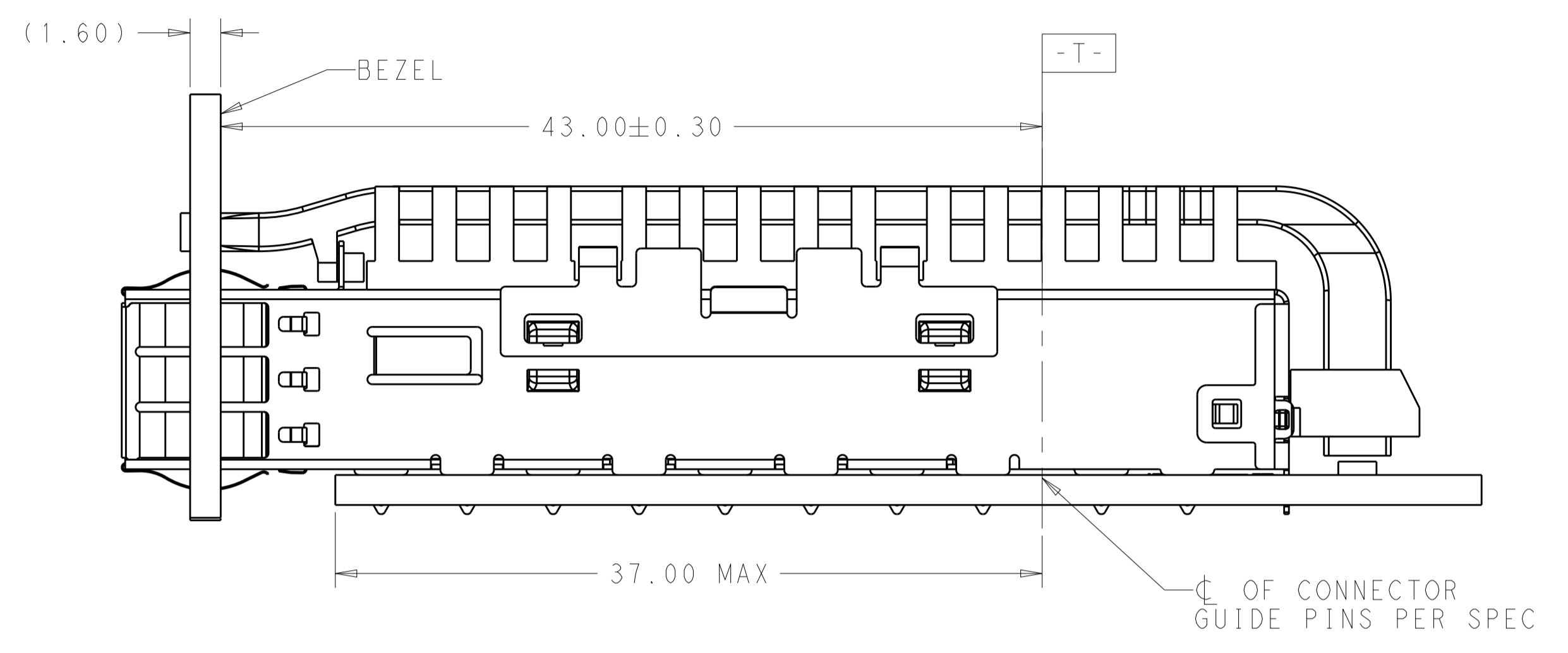

SINGLE SIDE MOUNTING
SCALE 4:1

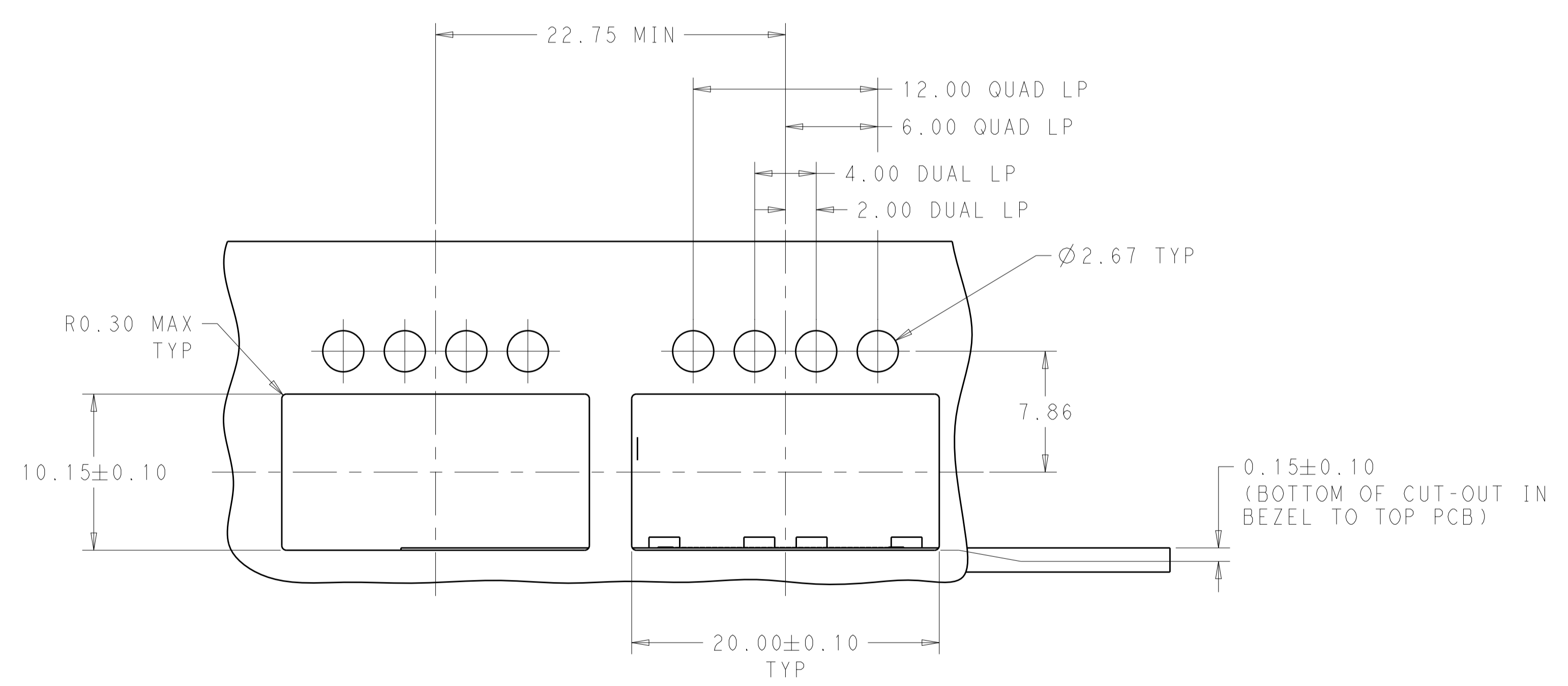

DUAL/QUAD LIGHT PIPE TYPE

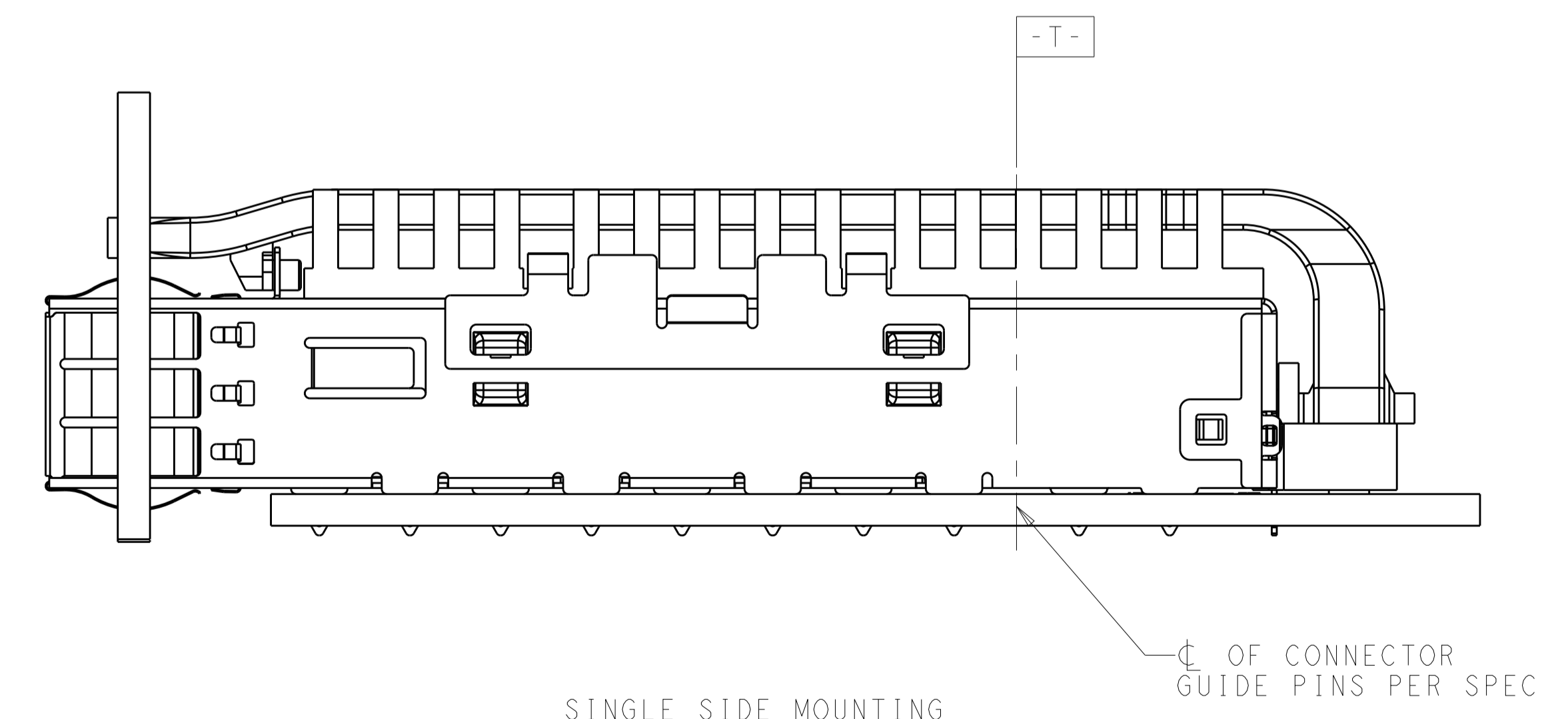

SINGLE SIDE MOUNTING
SCALE 4:1

THIS DRAWING IS A CONTROLLED DOCUMENT.		DMN: JASON YANG 07MAR2014	TE Connectivity
DIMENSIONS: mm		CHK: SEAN HAN 26JAN2016	
TOLERANCES UNLESS OTHERWISE SPECIFIED:		APVD:	NAME: CAGE ASSEMBLY, QSFP28, THRU BEZEL WITH EMI SPRING FINGER HEAT SINK, LIGHT PIPE
0 PLC ±0.25 1 PLC ±0.25 2 PLC ±0.25 3 PLC ±0.100 4 PLC ± ANGLES ±°		PRODUCT SPEC: 108-19428	SIZE: A1
MATERIAL: FINISH:		APPLICATION SPEC: 114-32023	CAGE CODE: 00779
		WEIGHT: CUSTOMER DRAWING	DRAWING NO: C=2170705
		SCALE: 2:1	SHEET 4 OF 7
			REV D

LOC		DIST		REVISIONS		
				DESCRIPTION	DATE	APPV
				SEE SHEET 1		

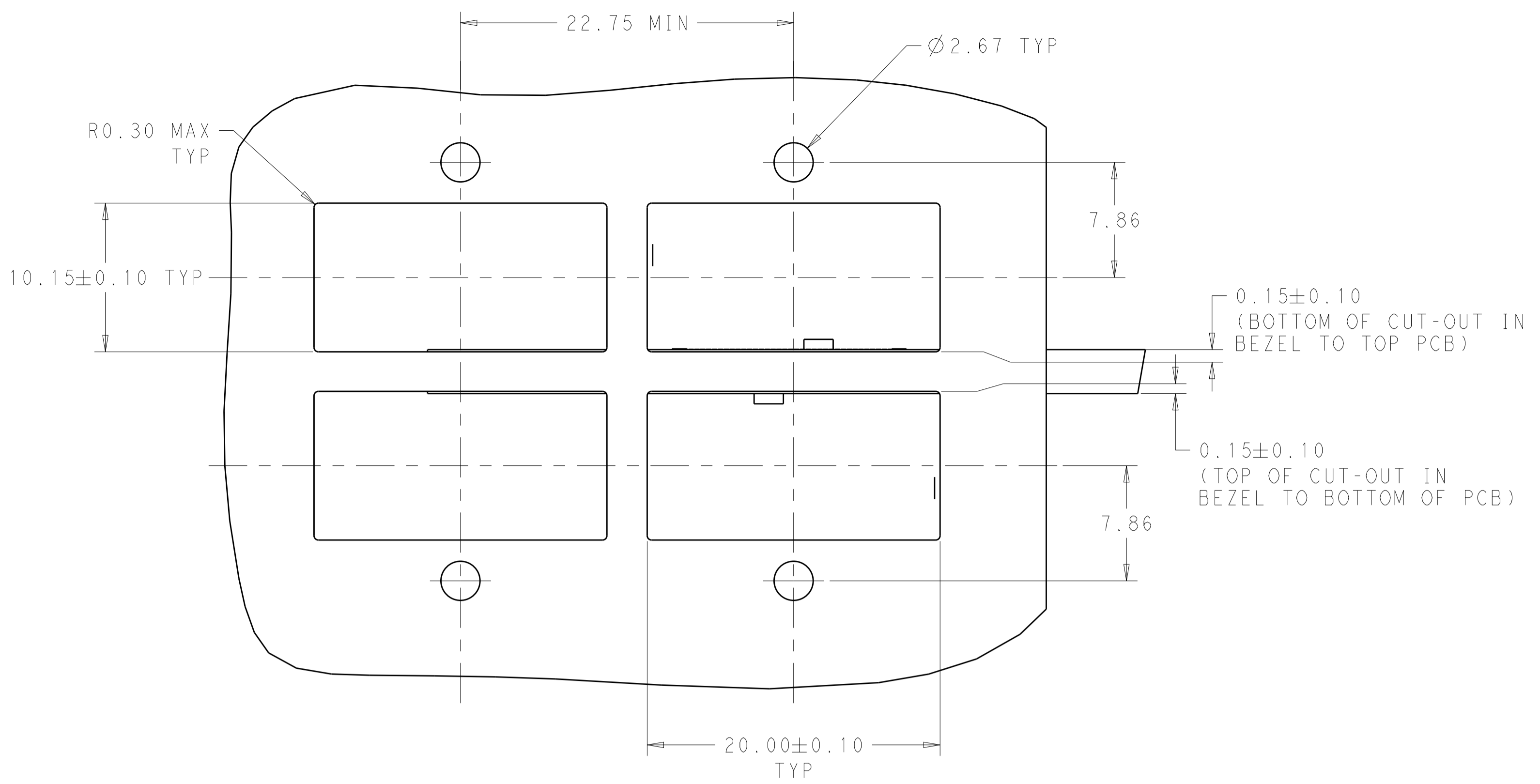

SINGLE LIGHT PIPE TYPE

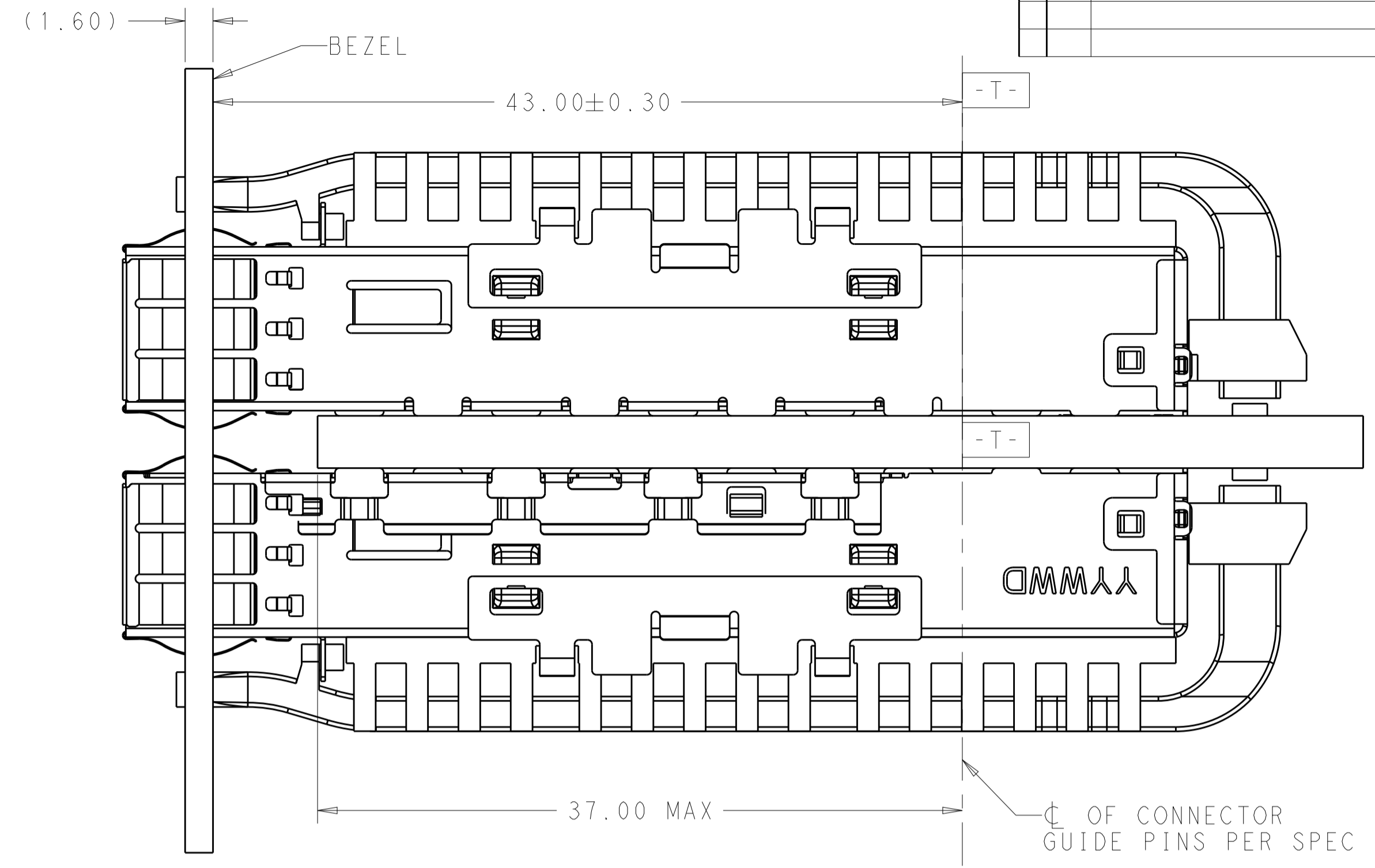

BELLY TO BELLY MOUNTING SCALE 4:1

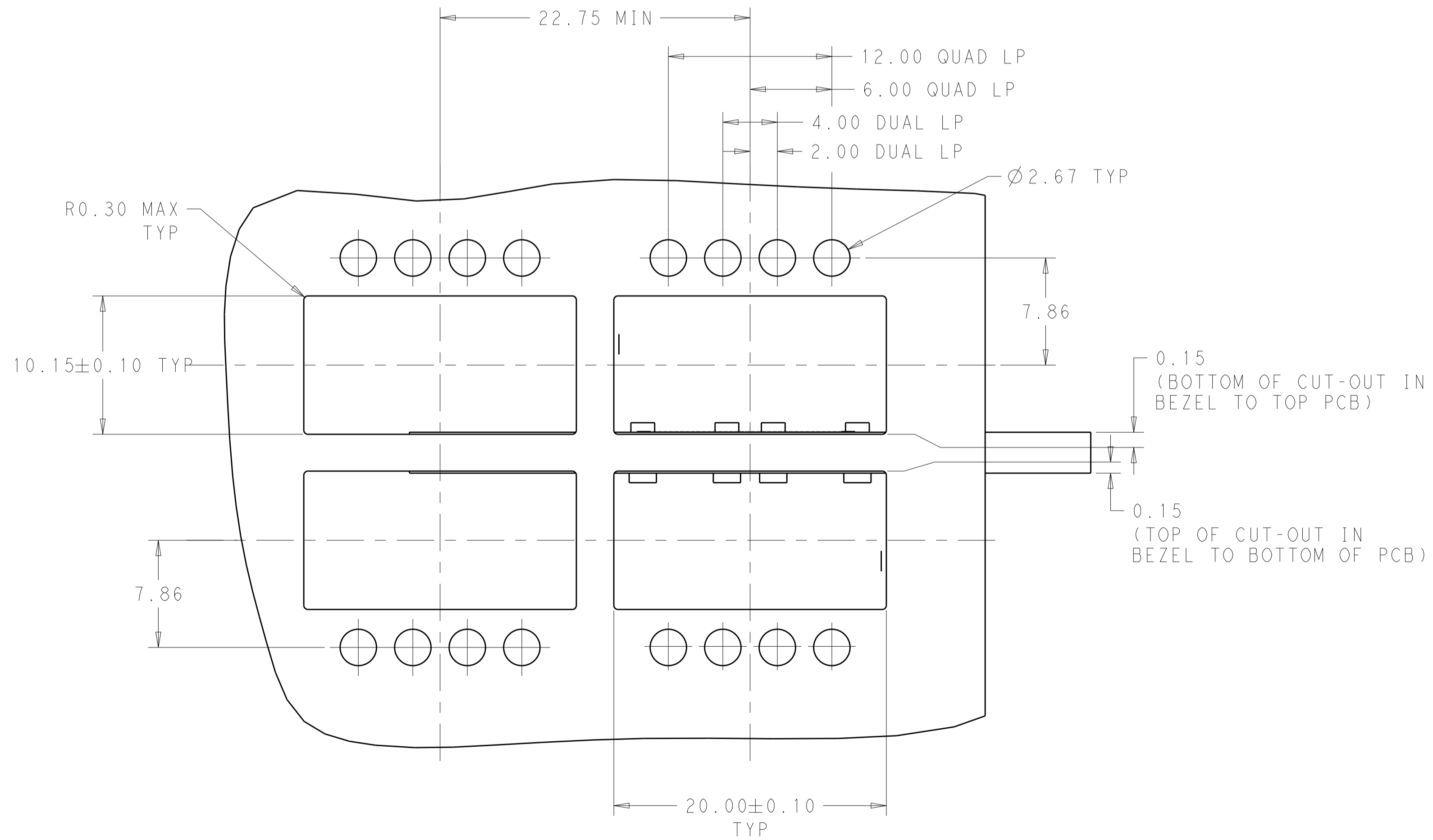

DUAL/QUAD LIGHT PIPE TYPE

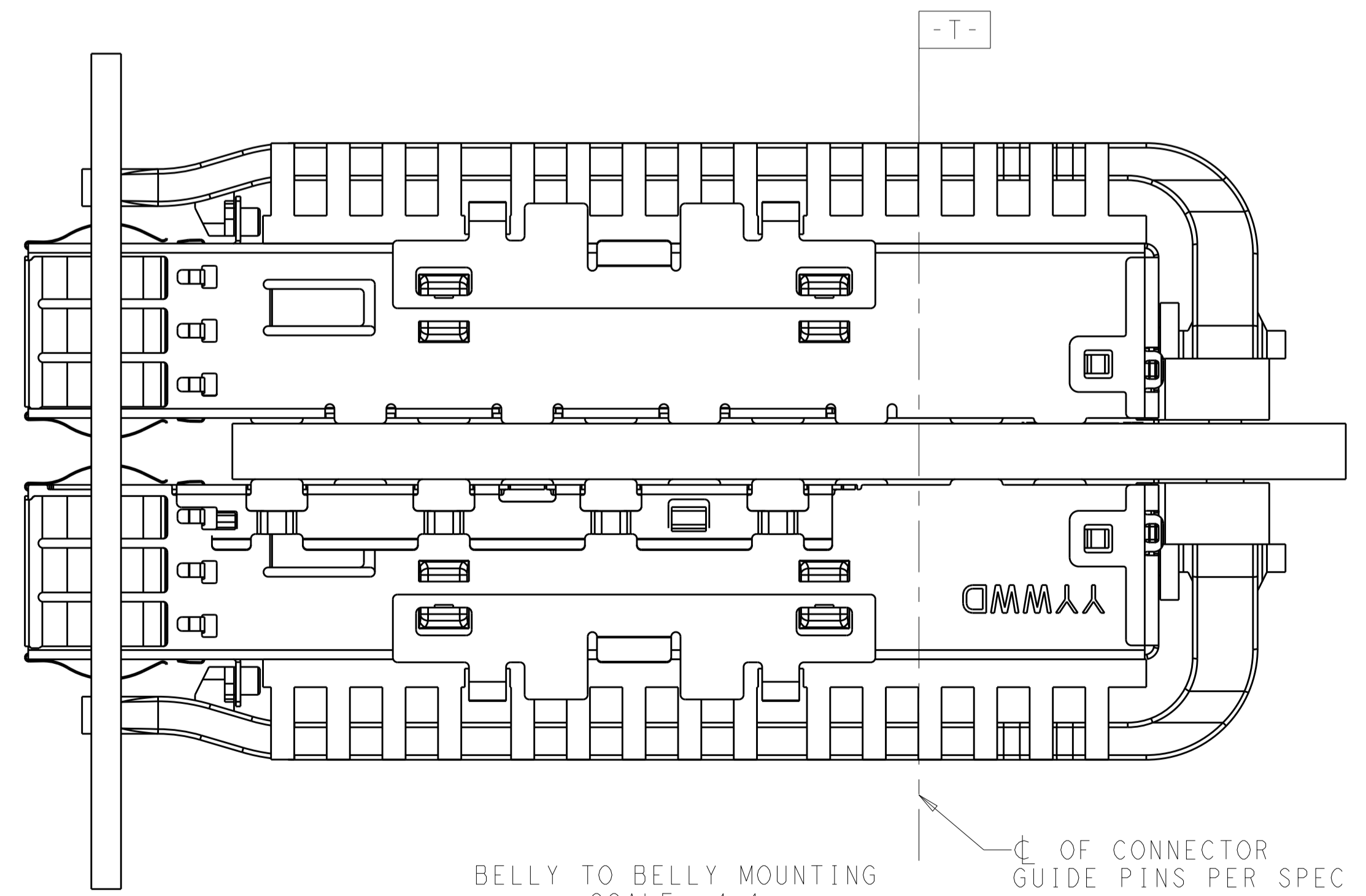

BELLY TO BELLY MOUNTING SCALE 4:1

THIS DRAWING IS A CONTROLLED DOCUMENT.		OWN: JASON YANG 07MAR2014	TE Connectivity
		CHK: SEAN HAN 26JAN2016	
DIMENSIONS:	TOLERANCES UNLESS OTHERWISE SPECIFIED:	APVD:	NAME:
mm	0 PLC ±0.25	PRODUCT SPEC	CAGE ASSEMBLY, QSPF28, THRU BEZEL
	1 PLC ±0.25	108-19428	WITH EMI SPRING FINGER
	2 PLC ±0.25	APPLICATION SPEC	HEAT SINK, LIGHT PIPE
	3 PLC ±0.25	114-32023	SIZE: CAGE CODE DRAWING NO
	4 PLC ±0.100	WEIGHT	A100779C=2170705
	ANGLES ±°	CUSTOMER DRAWING	RESTRICTED TO
MATERIAL:	FINISH:	SCALE 2:1	SHEET 5 OF 7 REV D

LOC		DIST		REVISIONS			
				DESCRIPTION	DATE	DMN	APVD
-	-	-	-	SEE SHEET 1	-	-	-

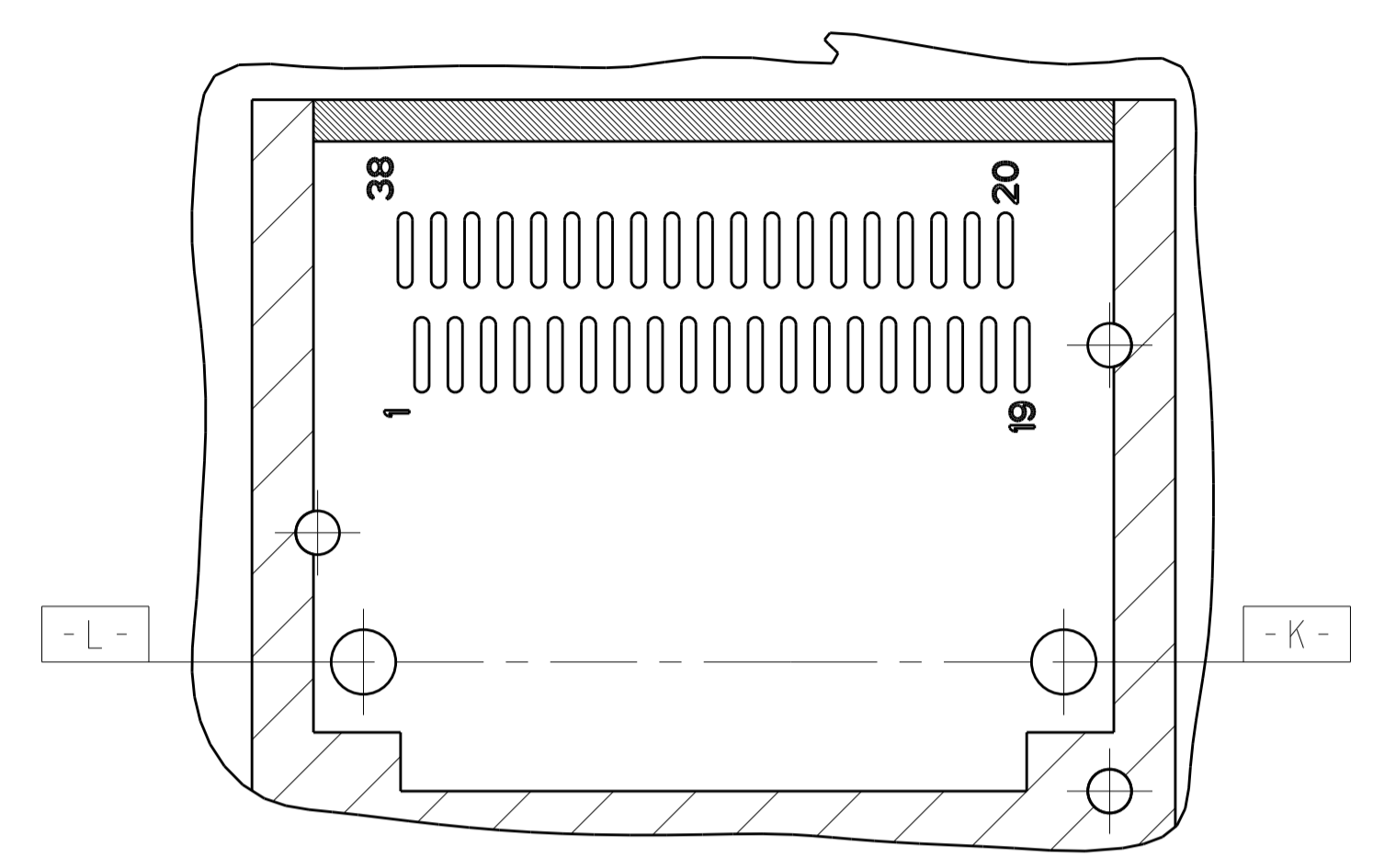
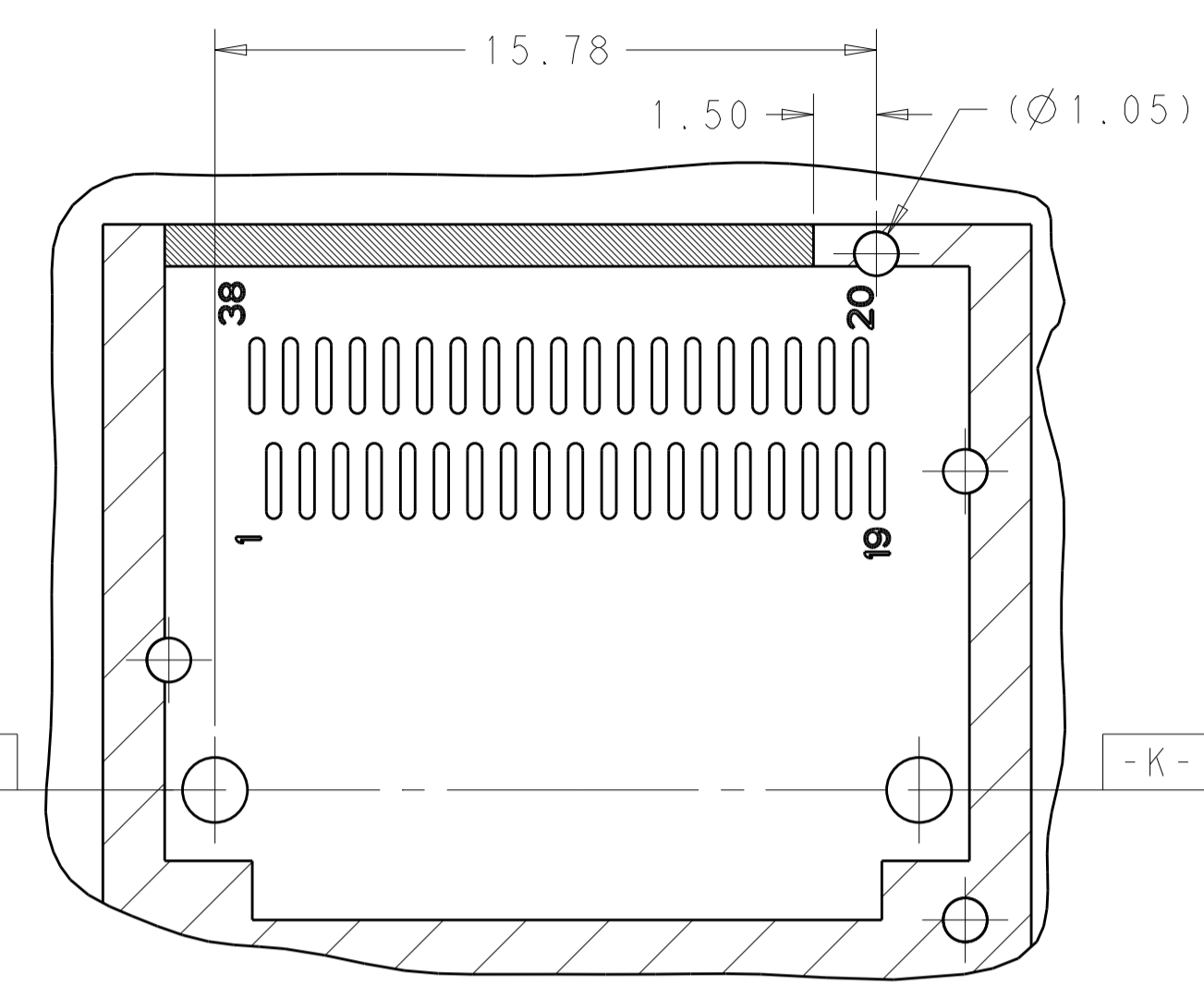
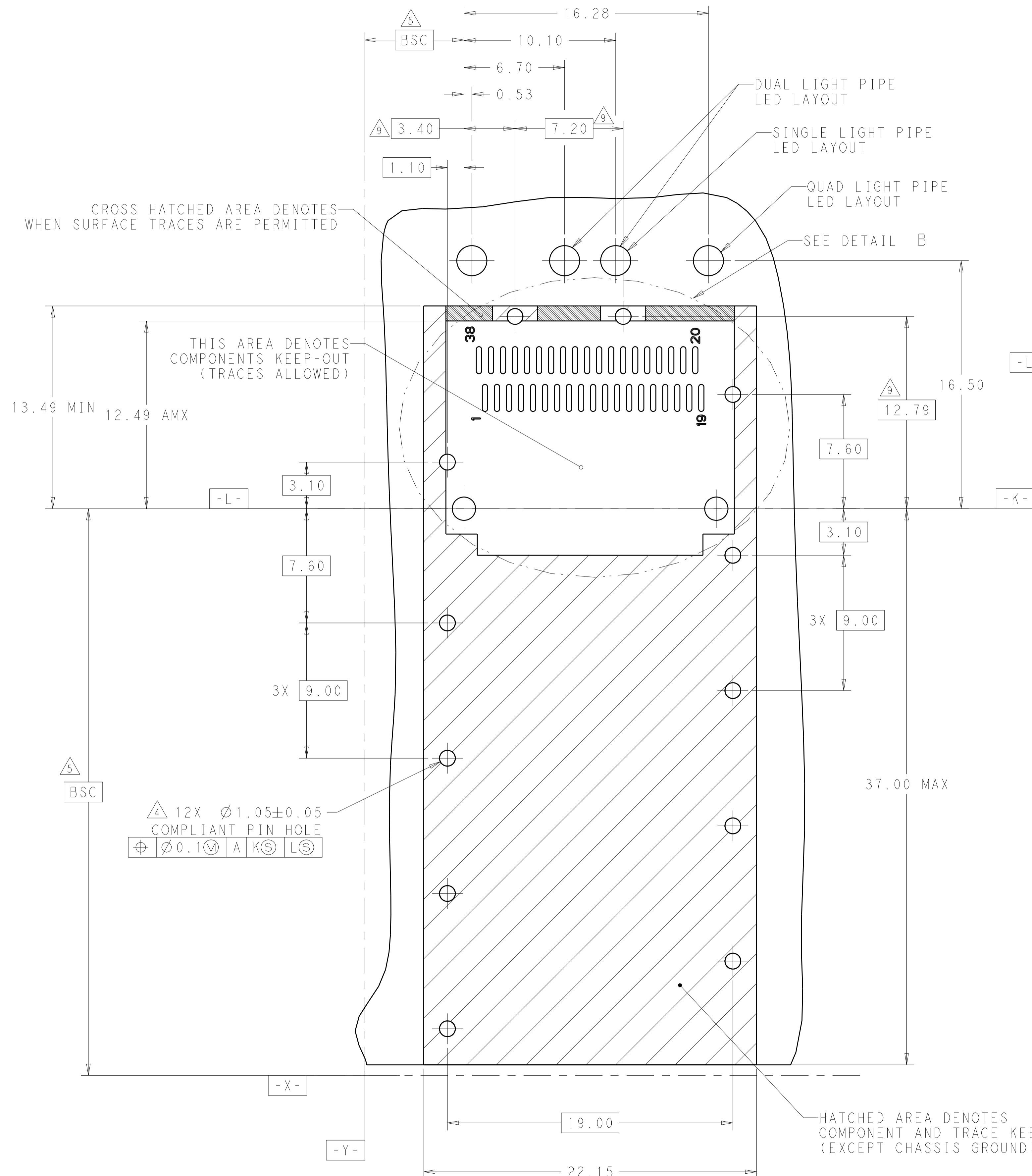

RECOMMENDED PCB LAYOUT
 SINGLE TYPE OF 1 REAR HOLES OF LEGS
 PCB TOLERANCE: ±0.05
 SCALE 6:1

RECOMMENDED PCB LAYOUT
 SINGLE TYPE OF 0 REAR HOLES OF LEGS
 PCB TOLERANCE: ±0.05
 SCALE 6:1

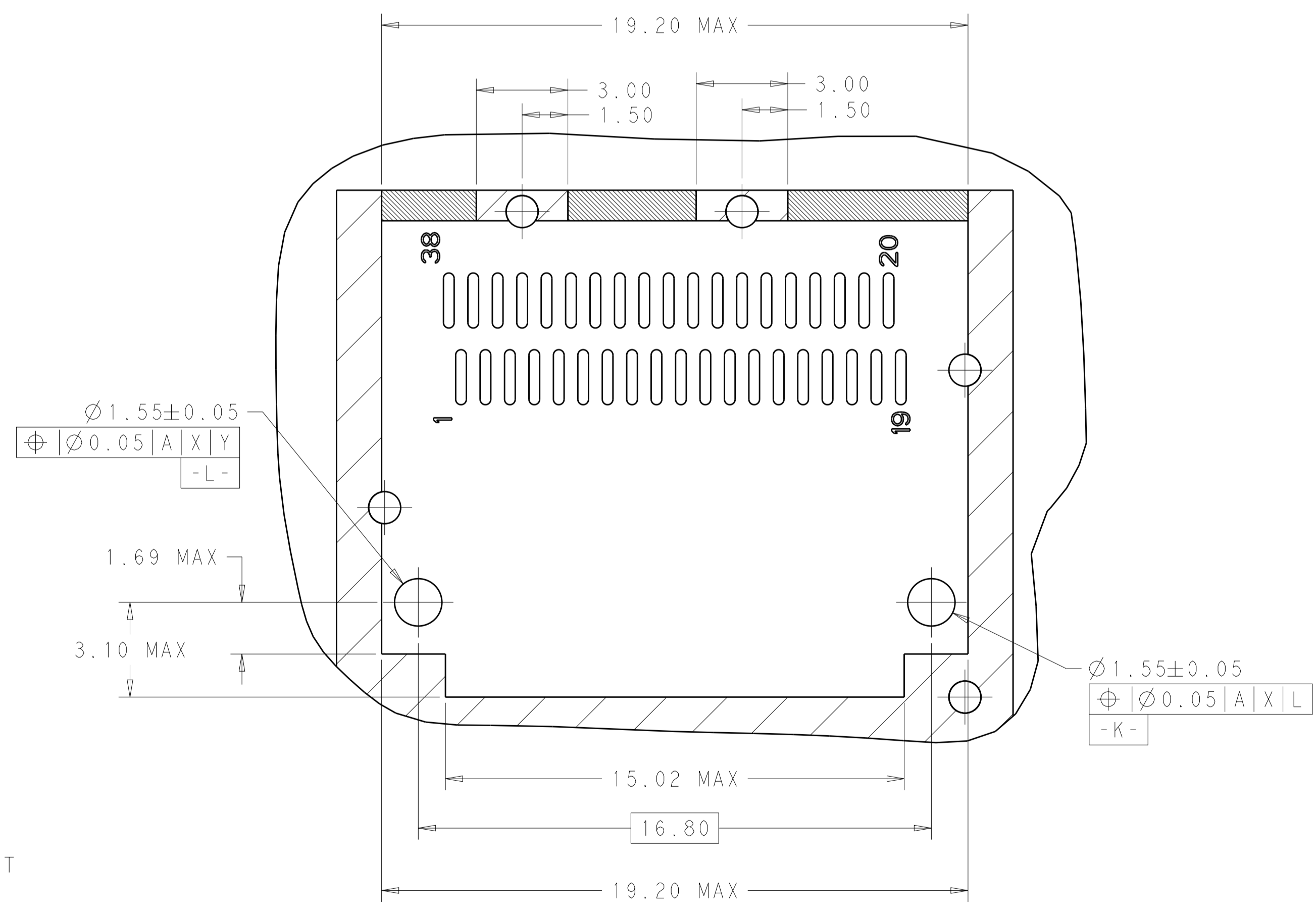

RECOMMENDED PCB LAYOUT
 SINGLE TYPE OF 2 REAR HOLES OF LEGS
 PCB TOLERANCE: ±0.05
 SCALE 6:1

THIS DRAWING IS A CONTROLLED DOCUMENT.		DMN: JASON YANG 07MAR2014	TE Connectivity
DIMENSIONS: mm		CHK: SEAN HAN 26JAN2016	
TOLERANCES UNLESS OTHERWISE SPECIFIED:		APVD:	NAME:
0 PLC ±0.25	1 PLC ±0.25	PRODUCT SPEC:	CAGE ASSEMBLY, QSFP28, THRU BEZEL
2 PLC ±0.20	3 PLC ±0.20	APPLICATION SPEC:	WITH EMI SPRING FINGER
4 PLC ±0.100	ANGLES ±°	SIZE: 114-32023	HEAT SINK, LIGHT PIPE
MATERIAL:	FINISH:	WEIGHT:	RESTRICTED TO:
CUSTOMER DRAWING		SCALE: 2:1	SHEET 6 OF 7

LOC		DIST		REVISIONS			
				DESCRIPTION	DATE	OWN	APVD
-	-	-	-	SEE SHEET 1	-	-	-

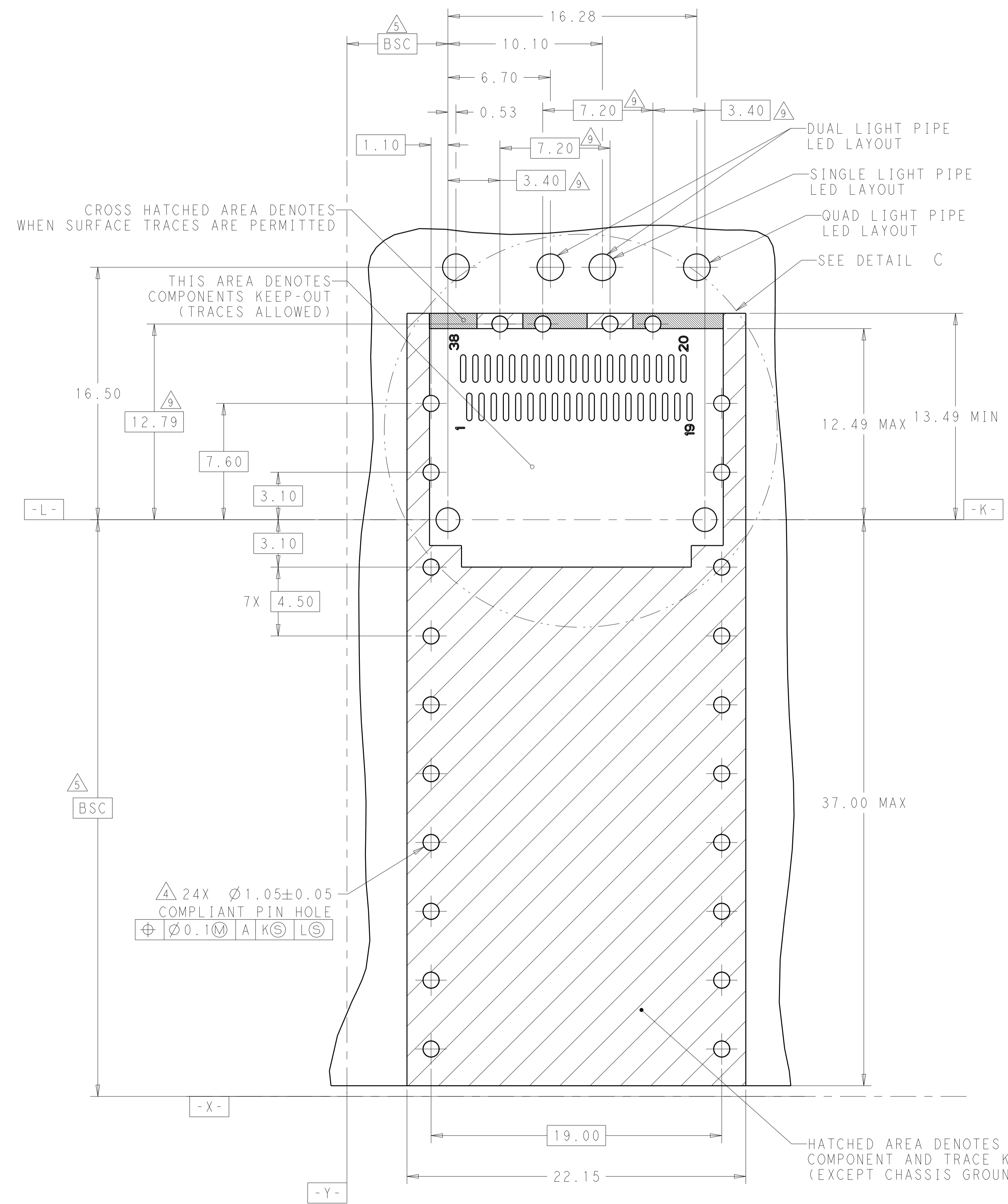

RECOMMENDED PCB LAYOUT
 BELLY TO BELLY TYPE OF 2 REAR HOLES OF LEGS
 PCB TOLERANCE: ±0.05
 SCALE 6:1

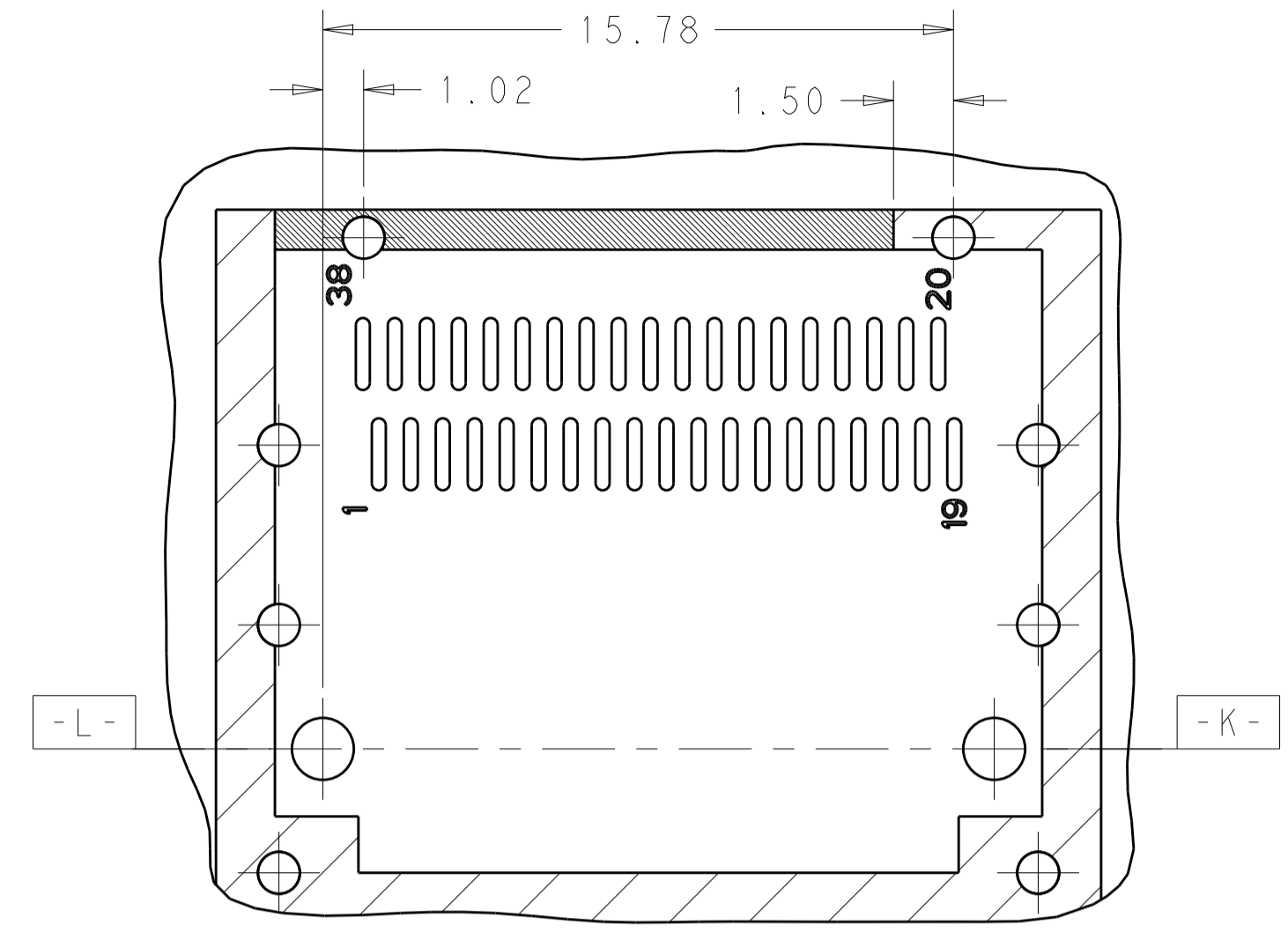

RECOMMENDED PCB LAYOUT
 BELLY TO BELLY TYPE OF 1 REAR HOLES OF LEGS
 PCB TOLERANCE: ±0.05
 SCALE 6:1

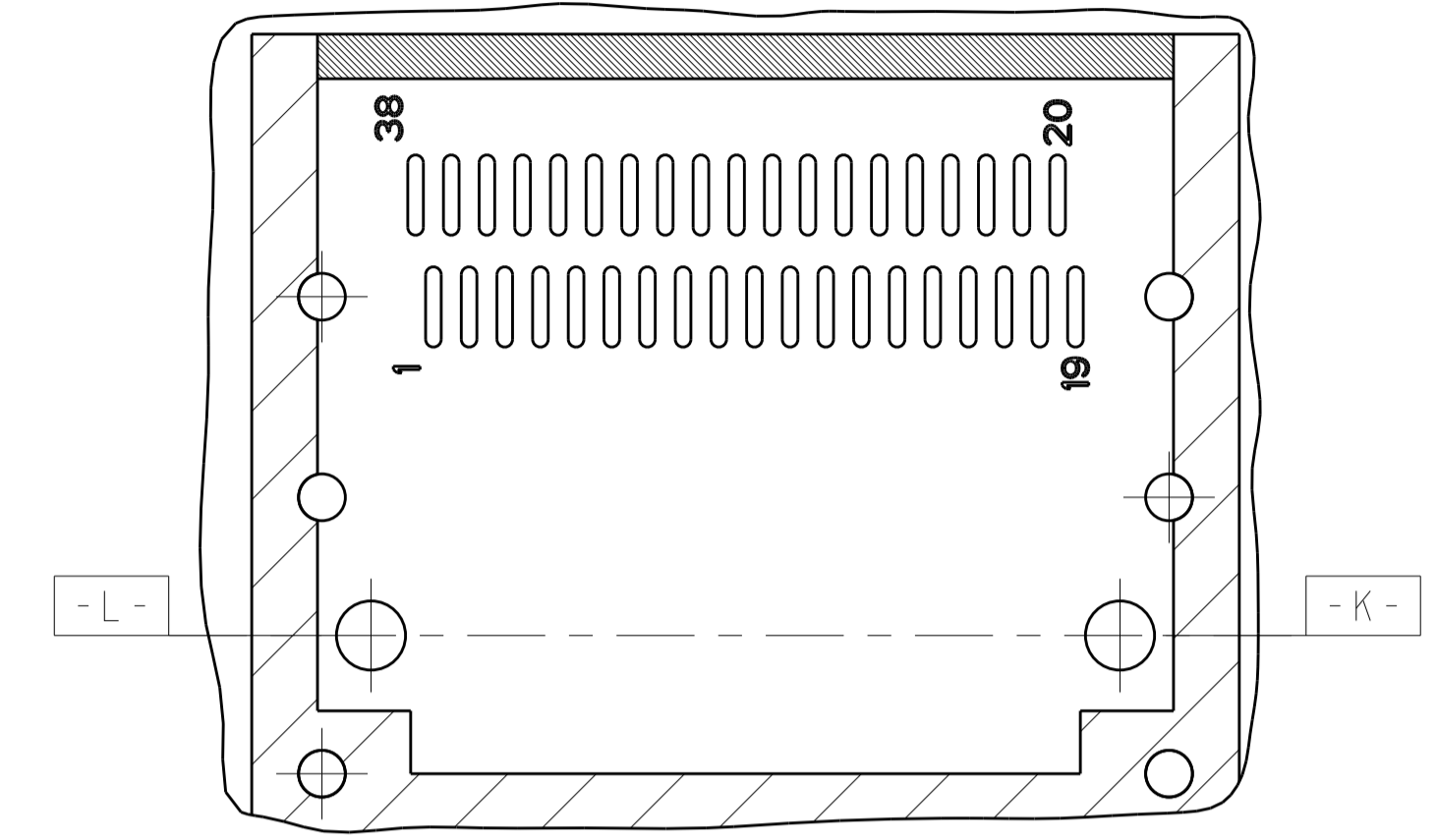

RECOMMENDED PCB LAYOUT
 BELLY TO BELLY TYPE OF 0 REAR HOLES OF LEGS
 PCB TOLERANCE: ±0.05
 SCALE 6:1

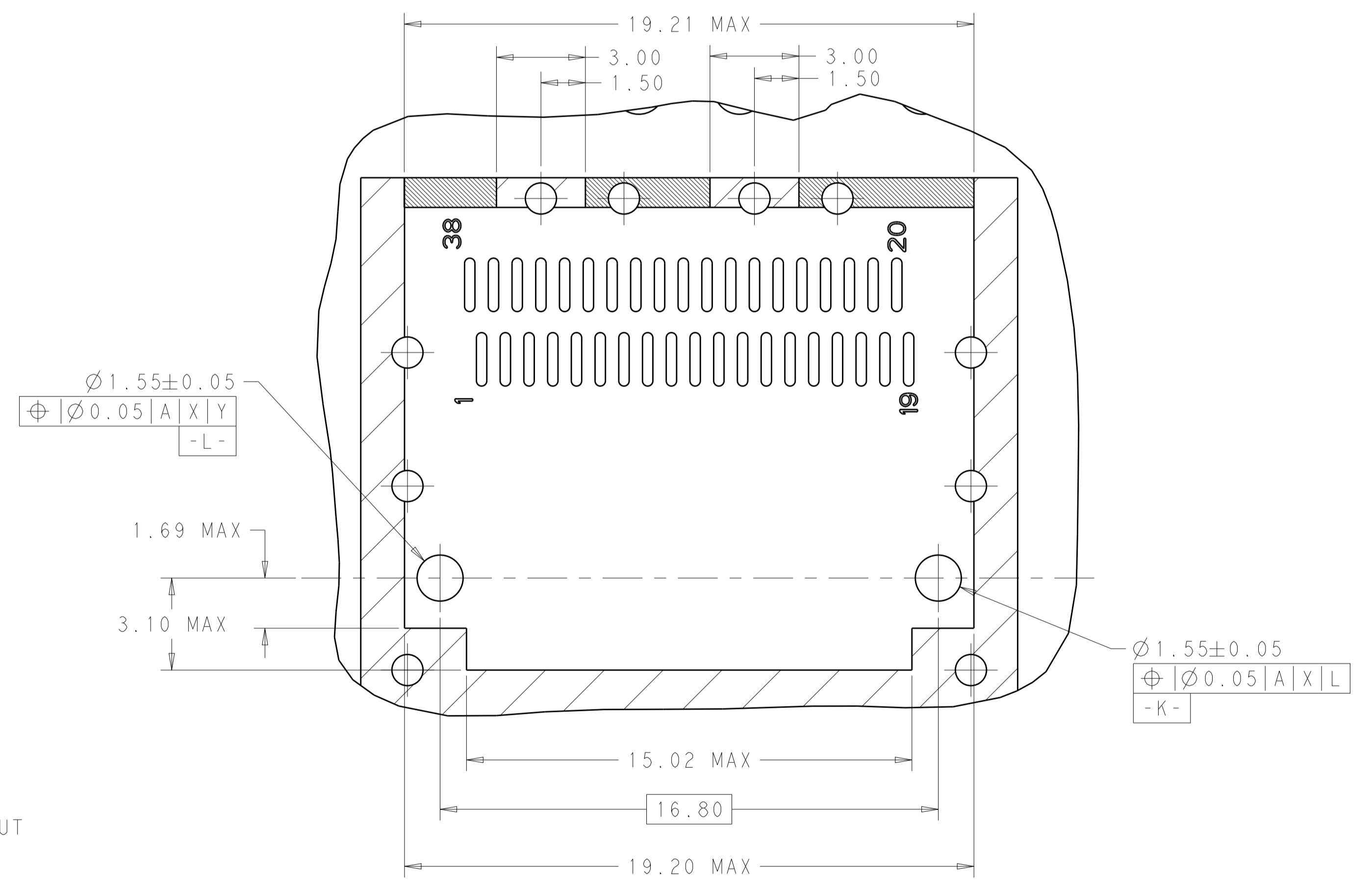

DETAIL C
 SCALE 8:1

THIS DRAWING IS A CONTROLLED DOCUMENT.		OWN: JASON YANG 07MAR2014	TE Connectivity
DIMENSIONS: mm		CHK: SEAN HAN 26JAN2016	
TOLERANCES UNLESS OTHERWISE SPECIFIED:		APVD:	NAME: CAGE ASSEMBLY, QSFP28, THRU BEZEL WITH EMI SPRING FINGER HEAT SINK, LIGHT PIPE
0 PLC ±0.25	1 PLC ±0.25	PRODUCT SPEC: 108-19428	SIZE: A1
2 PLC ±0.20	3 PLC ±0.100	APPLICATION SPEC: 114-32023	CAGE CODE: 2170705
4 PLC ±0.100	ANGLES ±0.100	WEIGHT:	RESTRICTED TO:
MATERIAL:	FINISH:	CUSTOMER DRAWING:	SCALE: 2:1 SHEET 7 OF 7 REV D