

Desktop instrument cases (110 series)

Product overview

Extensive range of high quality instrument cases for test, measurement, display and control applications. Functional push-fit construction designed for quick and easy assembly.

- Screwless push-fit assembly via 8x lock pins
- Horizontal PCB guides in side profiles
- Ventilation slots in lid and base
- Lid and base can be dismantled independently from each other
- 4x non-slip feet as standard (CDIC00001-4)
- 2x non-slip feet, 2x tilting feet and front handles as standard (CDIC00005-7)

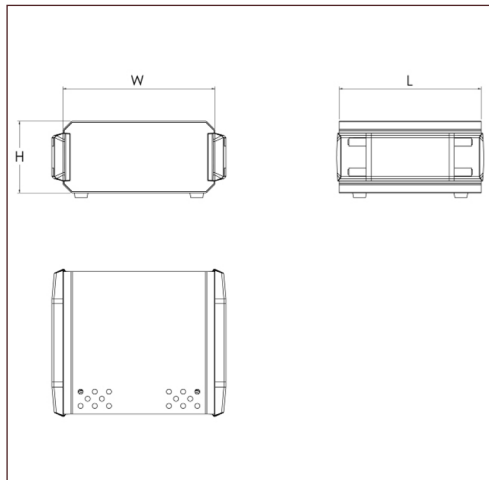
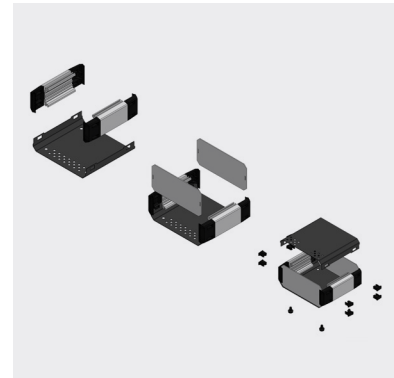

SPECIFICATION		
Material	High impact ABS Lid and base 1mm thick steel, epoxy coated, textured Side profiles extruded 6063 aluminium, matt silver anodised Brackets and tilting feet	
Material sizes 1-4	CDIC00001-4	Front/rear panels 1.5mm thick 5050 aluminium, silver anodised
Material sizes 5-7	CDIC00005-7	Front/rear panels 2mm thick 5050 aluminium, silver anodised
Standard unit sizes 1-4	CDIC00001-4	Lid and base 2x front/rear panels 2x aluminium side profiles 4x brackets 8x lock pins 4x non-slip feet
Standard unit sizes 5-7	CDIC00005-7	Lid and base 2x front/rear panels 2x aluminium side profiles 2x rear brackets 2x front brackets with handle 2x non-slip feet 2x non-slip tilting feet 8 x locking pins

DARK GREY	SIZE	LENGTH	WIDTH	HEIGHT
CDIC00001	1	145mm	171.6mm	70.4mm
CDIC00002	2	205mm	221.6mm	70.4mm
CDIC00003	3	175mm	246.6mm	80.4mm
CDIC00004	4	205mm	271.6mm	90.4mm
CDIC00005	5	271mm	327.5mm	100mm
CDIC00006	6	311mm	377.5mm	120mm
CDIC00007	7	351mm	427.5mm	130mm

KEY FEATURES

Push-fit assembly | High-impact ABS | Extruded side profiles



ACCESSORIES

Assembly plate

- The assembly plate is easily fixed to the enclosure using M3 screws and nuts
- 1 mm thick steel, zinc coated
- Assembly plate for mounting components

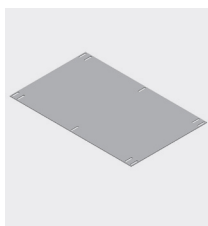

DARK GREY	SIZE	LENGTH	WIDTH
-	1	-	-
CDICMPO02	2	143mm	192mm
CDICMPO03	3	113mm	217mm
CDICMPO04	4	143mm	242mm
CDICMPO05	5	170mm	286.5mm
CDICMPO06	6	210mm	336.5mm
CDICMPO07	7	250mm	386.5mm