

Customer Information Sheet

DRAWING No.: M80-828XXXX

IF IN DOUBT - ASK

©

NOT TO SCALE

THIRD ANGLE PROJECTION

ALL DIMENSIONS IN mm

SPECIFICATIONS:

MATERIAL:
 MOULDING = G-F PPS UL94V-0, BLACK
 CONTACTS = PHOSPHOR BRONZE

FINISH:
CONTACTS:
 ALL FINISHES = NICKEL UNDERCOAT
 22 = 0.75µm GOLD ON CONTACT AREA,
 3.0µm 90/10 TIN/LEAD ON TAILS
 42 = 0.75µm GOLD ON CONTACT AREA,
 3.0µm 100% TIN ON TAILS
 45 = 0.75µm GOLD ALL OVER
 LATCH = 1.25µm NICKEL

PACKING:
 TUBE

FOR COMPLETE SPECIFICATION, SEE COMPONENT SPECIFICATION C005XX (LATEST ISSUE)

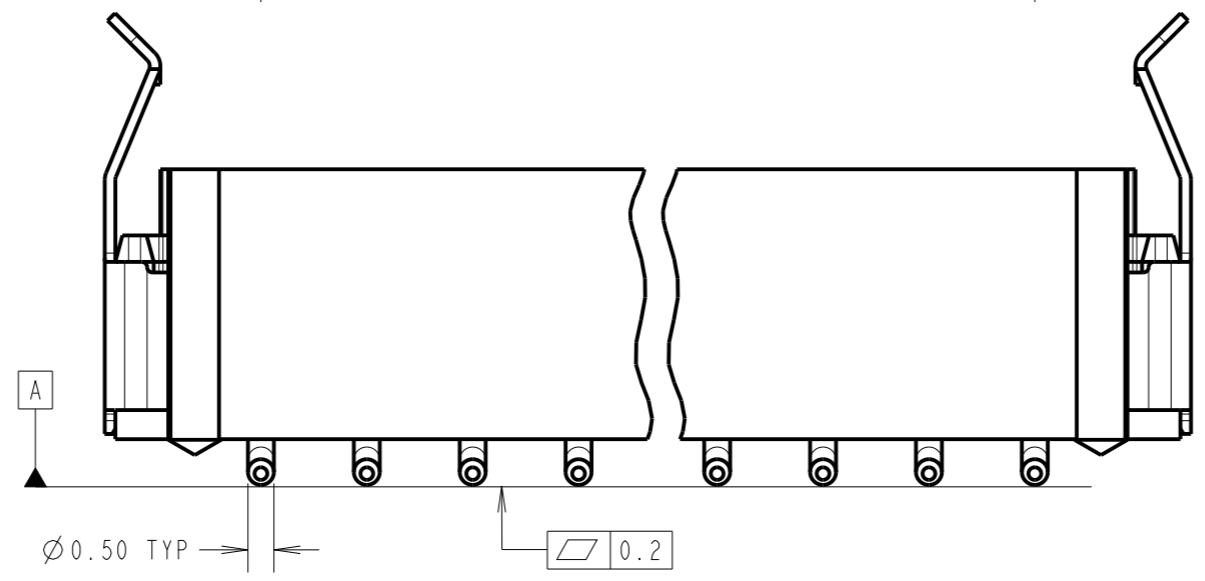
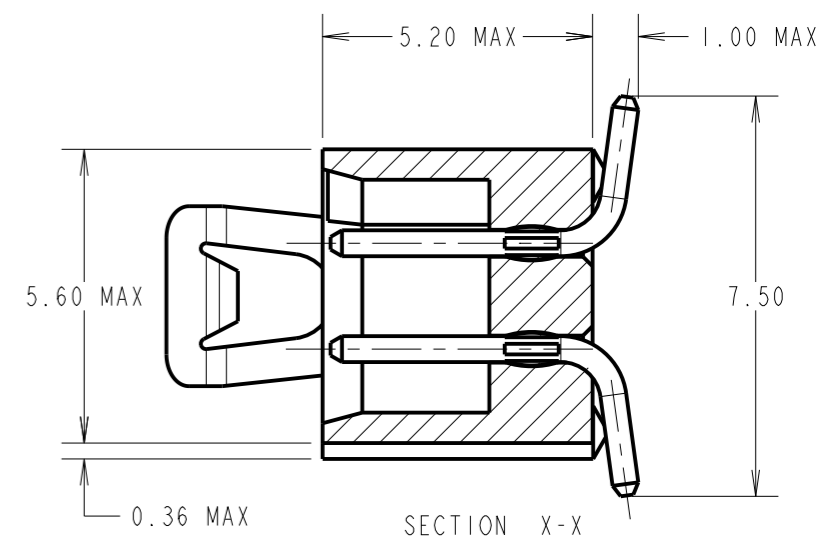
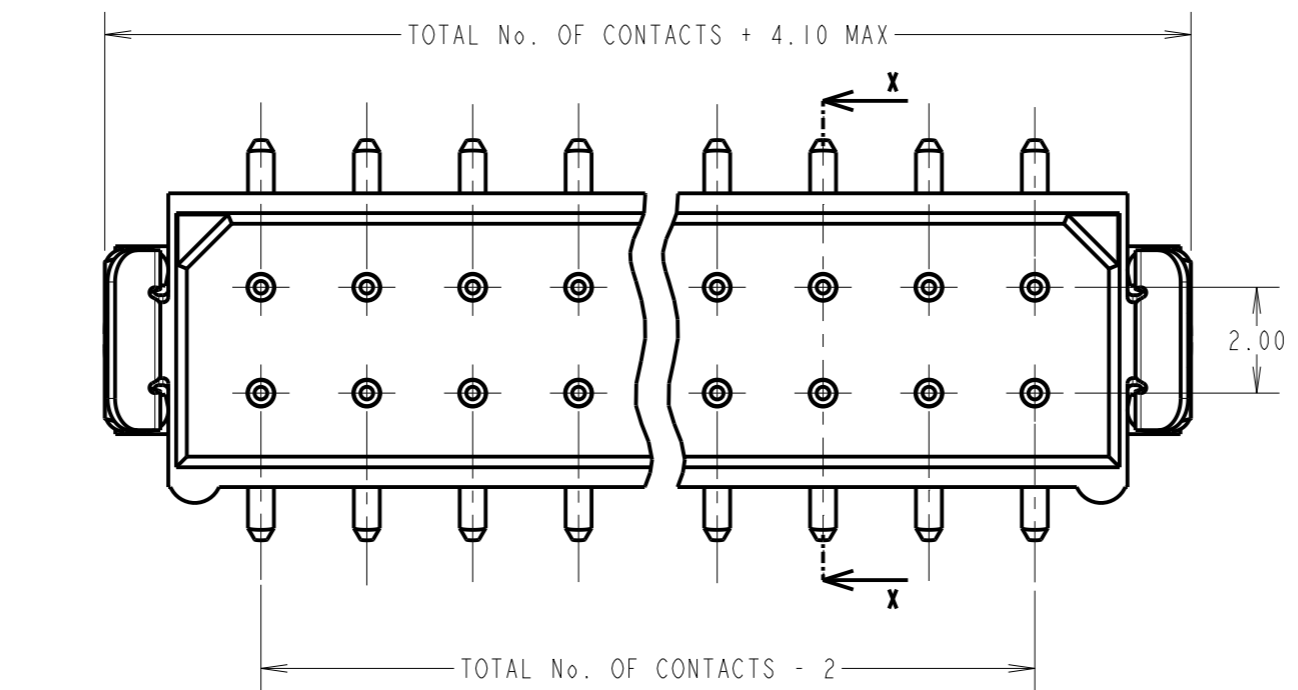

RECOMMENDED PCB LAYOUT
 TOLERANCE ±0.05mm

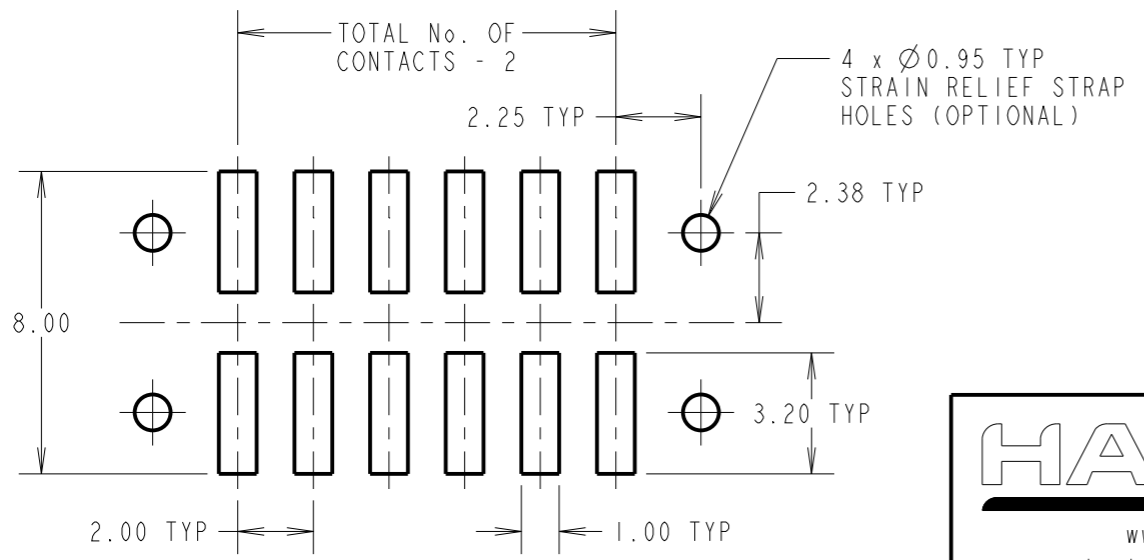

NOTES:
 1 .2-OFF STRAIN-RELIEF STRAPS M80-0030006 MAY BE USED WITH THIS CONNECTOR.

ORDER CODE:
M80-828XXXX

TOTAL No. OF CONTACTS: _____
 04, 06, 08, 10, 12, 14,
 16, 18, 20, 26, 34

FINISH: _____
 22 - SELECTIVE GOLD + TIN/LEAD
 42 - SELECTIVE GOLD + 100% TIN
 45 - GOLD

MGP	16	10.03.22	31413
NAME	ISS.	DATE	CN/CO
APPROVED: MGP			
CHECKED: RA			
DRAWN: A.LIOTTA			
CUSTOMER REF.:			
ASSEMBLY DRG:			

 www.harwin.com technical@harwin.com	THIS DRAWING AND ANY INFORMATION OR DESCRIPTIVE MATTER SET OUT HEREON ARE CONFIDENTIAL AND COPYRIGHT PROPERTY OF THE HARWIN GROUP AND MUST NOT BE DISCLOSED, LOANED, COPIED OR USED FOR MANUFACTURING, TENDERING OR FOR ANY OTHER PURPOSE WITHOUT THEIR WRITTEN PERMISSION.	TOLERANCES X. = ±1mm X.X = ±0.50mm X.XX = ±0.20mm X.XXX = ±0.01mm ANGLES = ±5° UNLESS STATED	MATERIAL: SEE ABOVE	TITLE: DATAMATE L-TEK MALE DIL VERTICAL SMT ASSEMBLY - LATCHED DRAWING NUMBER: M80-828XXXX	SHT 2 OF 2
			FINISH: SEE ABOVE S/AREA: mm ²		

Mouser Electronics

Authorized Distributor

Click to View Pricing, Inventory, Delivery & Lifecycle Information:

Harwin:

[M80-8280622](#) [M80-8281022](#) [M80-8282022](#) [M80-8280422](#) [M80-8281222](#) [M80-8280822](#) [M80-8282622](#) [M80-8280642](#) [M80-8281042](#) [M80-8282042](#) [M80-8281642](#) [M80-8280442](#) [M80-8281242](#) [M80-8280842](#) [M80-8283442](#) [M80-8282642](#) [M80-8281442](#) [M80-8283422](#) [M80-8281422](#) [M80-8281622](#) [M80-8281822](#) [M80-8281842](#) [M80-8280445](#) [M80-8280645](#) [M80-8280845](#) [M80-8281045](#) [M80-8281245](#) [M80-8281445](#) [M80-8281845](#) [M80-8282045](#) [M80-8282645](#)