

## PXU Temperature/Process Controller Installation Guide



See the Red Lion website at [www.redlion.net](http://www.redlion.net) for a complete user manual.



**CAUTION: Risk of electric shock.**

When the power is on, DO NOT touch the AC terminals, an electric shock may occur. Make sure the power is disconnected when you check the input power supply.

1. Prevent dust or metallic debris from falling into the controller and causing malfunctions. DO NOT modify the controller.
2. The PXU is an open-type device. Make sure it is installed in an enclosure free of dust and humidity in case of an electric shock.
3. Wait for one minute after the power is switched off to allow the unit to discharge. DO NOT touch the internal wiring within this period of time.

### SPECIFICATIONS

**POWER:**

**Line Voltage Models:**

100 to 240 VAC -20/+8 %, 50/60 Hz, 5 VA

**Low Voltage Models:**

DC Power: 24 VDC, ±10%, 5 W

**INPUT CAPABILITIES:**

**Thermocouple Inputs:**

Types: T, E, J, K, R, S, B, N, L, U, and TXK

**RTD Inputs:**

Type: 2 or 3 wire, 2 wire can be compensated for lead wire resistance

Excitation: 180 µA typical

Input Type:

100 Ω Pt alpha = .00385	100 Ω Pt alpha = .00392
120 Ω Nickel alpha = .00672	50 Ω Copper alpha = .00428

**Process Input Ranges:**

0-5 VDC	0-20 mA	0-50 mV
0-10 VDC	4-20 mA	

**USER INPUT (Optional):**

**Contact/NPN Open Collector Input:**

ON Resistance 1 KΩ max.  
 OFF Resistance 100 KΩ min.

**Response Time:** 1 sec max

**Functions:** Programmable

**OUTPUT:**

**CONTROL RELAY OUTPUTS (OUT1/OUT2):**

Type: Form A

Contact Rating: 5 A @ 250 VAC

Contact Isolation to all I/O: 2300 VAC for 1 min.

**CONTROL SSR DRIVE OUTPUT (OUT1):**

Rating: 12 VDC ± 10% @ 40 mA max.

**CONTROL OUTPUT (OUT1) Analog Models:**

Analog Types: 4 to 20 mA or 0 to 10 VDC

Isolation To Sensor & Communication Common: 500 VDC for 1 min.

Compliance: 10 VDC: 1 KΩ load min., 20 mA: 500 Ω load max.

**ALARMS: 2 relay alarm outputs.**

Type: Form A or Form C, model and alarm dependent

Contact Rating: 3 A @ 250 VAC

**ENVIRONMENTAL CONDITIONS:**

Operating Temperature Range: 0 to 50 °C

Storage Temperature Range: -20 to 65 °C

Vibration Resistance: Operational 10 to 55 Hz, 1 g

Shock Resistance: Operational 30 g

Operating and Storage Humidity: 80% max relative humidity (non-condensing) from 0°C to 50°C

Altitude: Up to 2000 meters

**CERTIFICATIONS AND COMPLIANCES:**

**CE Approved**

EN 61326-1 Immunity to Industrial Locations

Emission CISPR 11 Class A

EN 61010-1

RoHS Compliant

UL Listed: File #E179259

IP65 Enclosure rating (Face only)

**CONNECTIONS:** Wire-clamping screw terminals

**CONSTRUCTION:** Black plastic alloy case and panel latch. Black plastic textured bezel with transparent display window. Controller meets IP65 requirements for indoor use when properly installed. Installation Category II, Pollution Degree 2.

**WEIGHT:**

1/4 DIN: 11.0 oz (312 g)

1/8 DIN: 7.8 oz (221 g)

1/16 DIN: 5.3 oz (150 g)

### DIMENSIONS In inches (mm) - 1/16 DIN

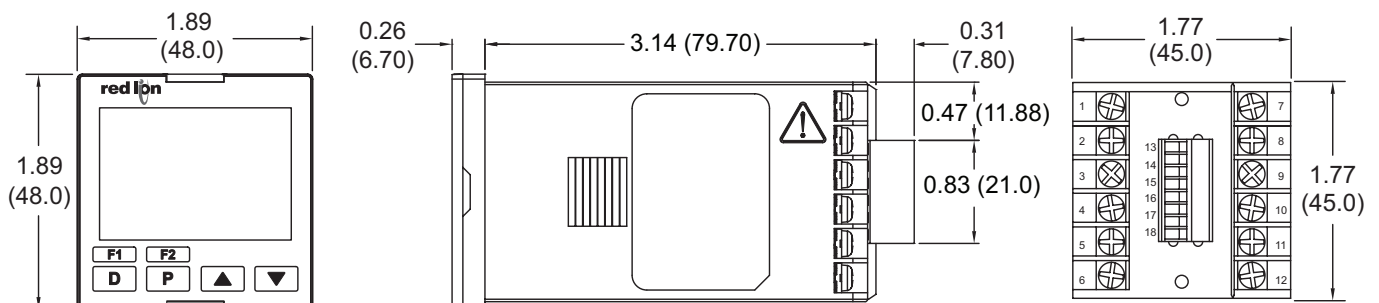

## DIMENSIONS In inches (mm) - 1/8 DIN

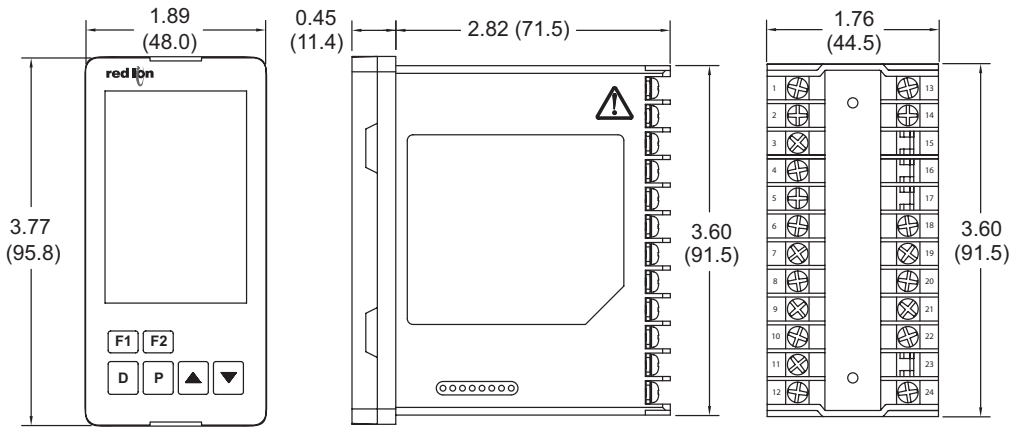

## DIMENSIONS In inches (mm) - 1/4 DIN

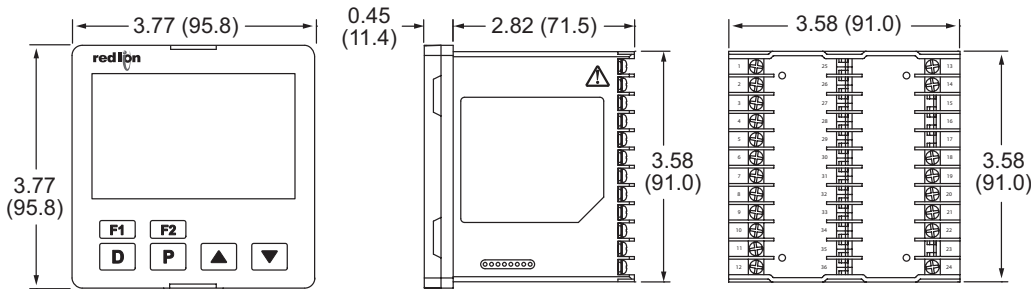

**CAUTION: Risk of Danger.**  
Read complete instructions prior to installation and operation of the unit.

## SETTING THE CURRENT INPUT JUMPER

When Input Type is selected as one of the two current input types (0-20 or 4-20), the current input jumper must be installed. The current input jumper is factory set for Temperature and Voltage input types. To change the jumper to configure the input for a current input type, the inside of the unit must be accessed and the jumper position changed.

To access the jumper, locate the two latches located on top and bottom of the front of the unit. Starting with the top latch, insert a small flat-blade screwdriver between the case latch and bezel while using your thumb to push out on the bezel until the latch is disengaged. Repeat this process with the bottom latch. After the latches are disengaged, using the flat-blade screwdriver, gently pry out on the bezel in several areas until the unit releases from the case.

Look for the Current Input Jumper which will be located close to the pc board area that connects to the input terminals. If a current input type is desired, position the jumper across both pins. If input type is anything other than a current input, position the jumper on only one pin.

### Thermocouple, RTD or Voltage Input

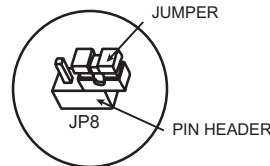

**FACTORY SETTING**

### Current Input (4-20 mA or 0-20 mA)

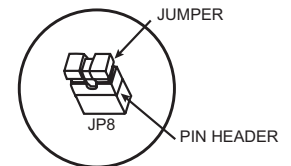

## INSTALLING THE CONTROLLER

The controller is designed to be mounted into an enclosed panel. The unit must be inserted in the case during installation of the controller.

### Instructions:

1. Prepare the panel cutout to the proper dimensions.
2. Assemble the mounting clip by inserting the nut into the slot and then insert the screw and thread through the nut as shown (See drawing)
3. Slide the panel gasket over the rear of the controller, seating it against the lip at the front of the case.
4. Insert the controller into the panel cutout. While holding the controller in place, install the panel latch(es) and then slide it to the farthest forward slot possible.
5. To achieve a proper seal, tighten the panel latch screws evenly until the controller is snug in the panel, torquing the screws to 13.9 to 20.8 oz-in (9.8 to 14.7 N-cm). Overtightening can result in distortion of the controller, and reduce the effectiveness of the seal.

*Note: The installation location of the controller is important. Be sure to keep it away from heat sources (ovens, furnaces, etc.) and away from direct contact with caustic vapors, oils, steam, or any other process by-products in which exposure may affect proper operation.*

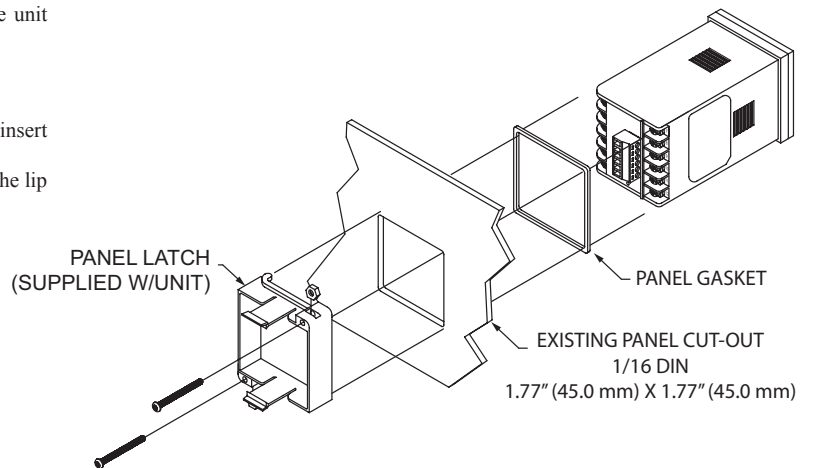

**1/16 DIN Installation**

## 1/8 DIN Installation

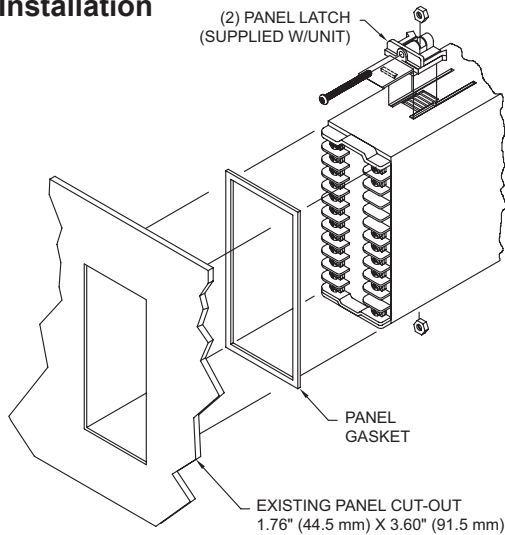

## 1/4 DIN Installation

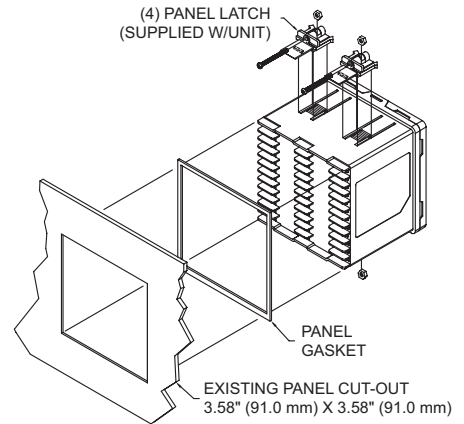

## CONTROLLER POWER CONNECTIONS

For best results, the power should be relatively "clean" and within the specified limits. Drawing power from heavily loaded circuits or from circuits that also power loads that cycle on and off should be avoided. It is recommended that power supplied to the controller be protected by a fuse or circuit breaker.

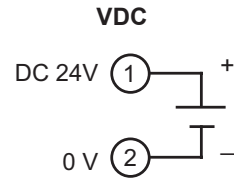
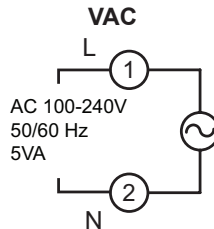

## INPUT CONNECTIONS

For two wire RTDs, install a copper sense lead of the same gauge and length as the RTD leads. Attach one end of the wire at the probe and the other end to input common terminal. This is the preferred method as it provides complete

lead wire compensation. If a sense wire is not used, then use a jumper. A temperature offset error will exist. The error may be compensated by programming a temperature offset.

### RTD and Resistance

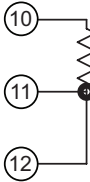

### Thermocouple and Millivolt

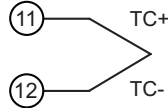

### Voltage and Current

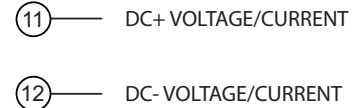

## CONTROL AND ALARM OUTPUT CONNECTIONS

### Alarm 1 and 2 \* (1/16 DIN Shown)

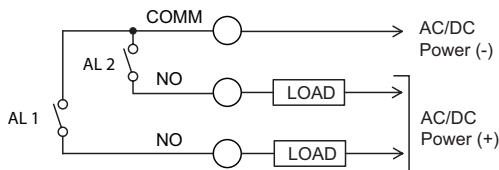

### OP1/OP2 Output Control Relay \*

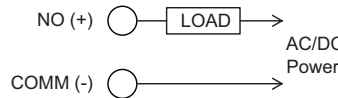

### OP1 Output Control Logic/SSR \*

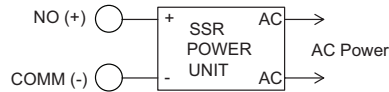

### OP1 Output Control Analog \*

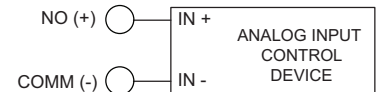

## USER INPUT CONNECTIONS \*

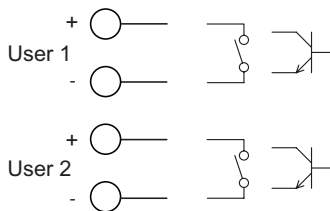

## RS 485 CONNECTIONS \*

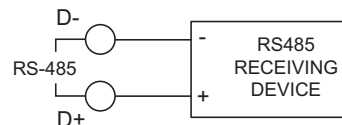

\* See unit label for terminal identification.

## ORDERING INFORMATION

MODEL NO.	DIN SIZE	MAIN CONTROL OUTPUT 1	SECONDARY CONTROL OUTPUT 2	USER INPUT(S)	RS 485	PART NUMBERS	
						100 to 240 VAC	24 VDC
PXU	1/16	Relay	-	-	-	PXU10020	PXU100B0
		Relay	Relay	2	Yes	PXU11A20	PXU11AB0
		Logic/SSR	-	-	-	PXU20020	PXU200B0
		Logic/SSR	Relay	2	Yes	PXU21A20	PXU21AB0
		4-20 mA	-	-	-	PXU30020	PXU300B0
		4-20 mA	Relay	2	Yes	PXU31A20	PXU31AB0
	1/8 (vertical)	Relay	-	-	-	PXU10030	PXU100C0
		Relay	Relay	2	Yes	PXU11A30	PXU11AC0
		Logic/SSR	-	-	-	PXU20030	PXU200C0
		Logic/SSR	Relay	2	Yes	PXU21A30	PXU21AC0
		4-20 mA	Relay	2	Yes	PXU31A30	PXU31AC0
	1/4	Relay	Relay	2	Yes	PXU11A50	PXU11AE0
		4-20 mA	Relay	2	Yes	PXU31A50	PXU31AE0

Only stocked part numbers are listed. Contact factory for availability of non-stock models.  
In order to program the unit using Crimson, the unit must be purchased with the 485 option.

## ACCESSORIES

MODEL NO.	DESCRIPTION	PART NUMBERS
RLY	External SSR Power Unit (for Logic/SSR models)	RLY50000
	25 A Single Phase Din Rail Mount Solid State Relay	RLY60000
	40 A Single Phase Din Rail Mount Solid State Relay	RLY6A000
	Three Phase Din Rail Mount Solid State Relay	RLY70000
SFCRD	Crimson PC Configuration Software	SFCRD200

<sup>1</sup> Crimson software is a free download from <http://www.redlion.net>



Do not dispose of unit in trash - Recycle

### LIMITED WARRANTY

The Company warrants the products it manufactures against defects in materials and workmanship for a period limited to two years from the date of shipment, provided the products have been stored, handled, installed, and used under proper conditions. The Company's liability under this limited warranty shall extend only to the repair or replacement of a defective product, at The Company's option. The Company disclaims all liability for any affirmation, promise or representation with respect to the products.

The customer agrees to hold Red Lion Controls harmless from, defend, and indemnify RLC against damages, claims, and expenses arising out of subsequent sales of RLC products or products containing components manufactured by RLC and based upon personal injuries, deaths, property damage, lost profits, and other matters which Buyer, its employees, or sub-contractors are or may be to any extent liable, including without limitation penalties imposed by the Consumer Product Safety Act (P.L. 92-573) and liability imposed upon any person pursuant to the Magnuson-Moss Warranty Act (P.L. 93-637), as now in effect or as amended hereafter.

No warranties expressed or implied are created with respect to The Company's products except those expressly contained herein. The Customer acknowledges the disclaimers and limitations contained herein and relies on no other warranties or affirmations.