

# AVERY DENNISON MARKETING SPECIFICATION

THE SUBJECT MATTER DISCLOSED HEREIN EMBODIES PROPRIETARY INFORMATION WHICH IS THE CONFIDENTIAL PROPERTY OF THE AVERY DENNISON CO. NONE OF WHICH SHALL BE COPIED, REPRODUCED, DISCLOSED TO OTHERS, PUBLISHED OR USED IN WHOLE OR IN PART, FOR ANY PURPOSE OTHER THAN THAT FOR WHICH IT IS BEING MADE AVAILABLE WITHOUT THE EXPRESS ADVANCE WRITTEN PERMISSION OF A DULY AUTHORIZED AGENT OF THE COMPANY. THIS DOCUMENT IS THE PROPERTY OF THE AVERY DENNISON CO. AND IS TO BE RETURNED TO THE COMPANY ON DEMAND.

## HISTORY

| REV. | DATE     | DESCRIPTION   |
|------|----------|---|
| P    | 07.15.09 | UPDATE MATERIAL DESCRIPTION   |
| Q    | 08.08.12 | BALLOON 5 CHG TO MATCH ACT  |
| R    | 09.05.14 | CHG DIM 1 TO BE TAKEN FROM BOTTOM OF THE HEAD. MADE MM THE PRIMARY UNITS                                      |
| S    | 04.12.17 | ADDED SPECIAL CHARACTERISTICS: 170.1/168.0 WAS DIM 5. CHG TO 168.7 REF. ALL BALLOONS AFTER 5 WERE RE-NUMBERED |

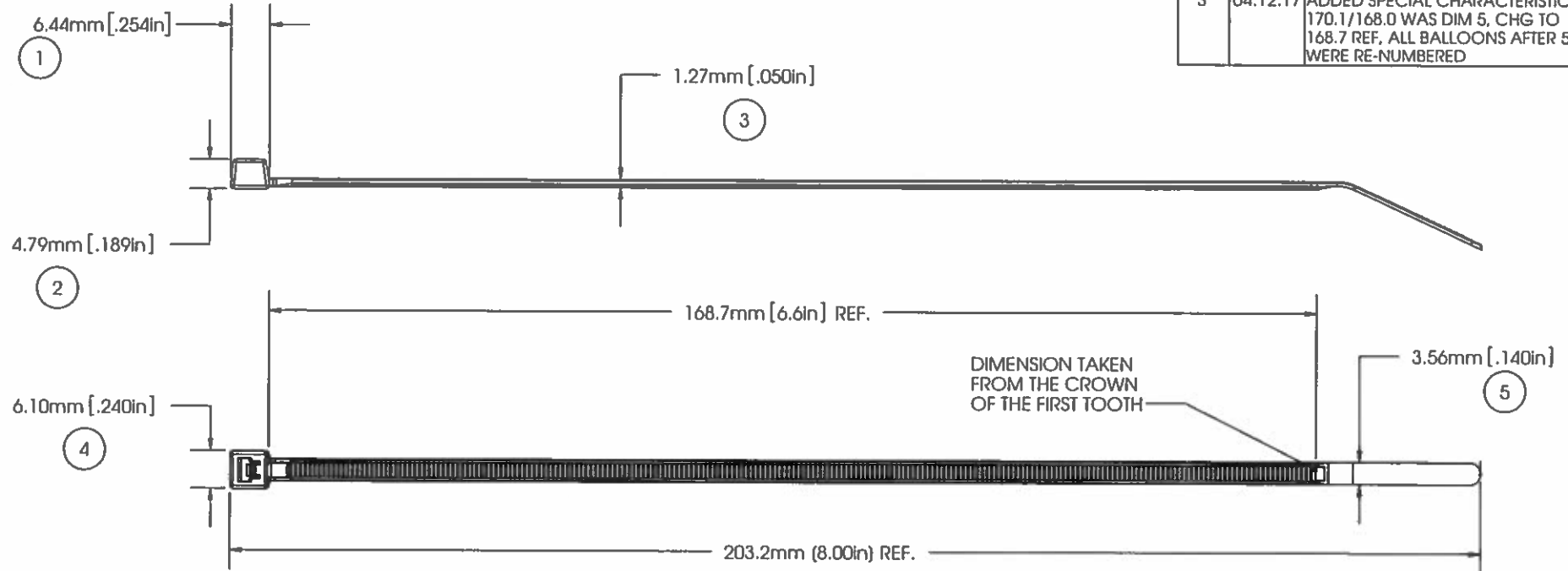

### NOTE:

1. SPECIAL CHARACTERISTICS ARE NOTED BY A TRIANGLE ( Δ )

|   |                         |   |
|---|-------------------------|---|
| ⑥ | Δ FLAMMABILITY RATING:  | HB RATED PER FMVSS302   |
| ⑦ | Δ TENSILE STRENGTH:     | 40 LBF /180N MIN. PER AS-23190                                    |
|   | OPERATING TEMP:         | -40°F(-40°C) TO 220°F (105°C)                                     |
|   | MIN. INSTALLATION TEMP: | 32°F(0°C)   |
|   | WEIGHT:                 | 1.0g/0.04oz.  |
|   | BUNDLE DIAMETER:        | Ø 1.6mm TO Ø 54.0mm   |
|   | TOOL:                   | 12001 - HAND INSTALLATION TOOL<br>12500 - PNUM. INSTALLATION TOOL |
|   | TOOL TENSION SETTING:   | 3-5   |
|   | PACKAGING:              | 1000/BAG, 5000/CASE   |

|            |            |  |
|------------|------------|--|
| APPROVALS: | ENG. APPR. | <i>[Signature]</i> 4/12/17             |
|            | Q.A. APPR. | <i>Carlin &amp; Ailancourt</i> 4/12/17 |

|                           |              |
|---------------------------|--------------|
| SPECIFIED TOLERANCES ARE: |              |
| .XX ± .03 in.             | .X ± 0.8 mm  |
| .XXX ± .010 in.           | .XX ± .25 mm |
| ANGULAR: ± 2°             |              |

|          |                               |
|----------|-------------------------------|
| MATERIAL | NYLON 6/6,<br>HEAT STABILIZED |
| COLOR    | BLACK                         |

|                       |   |
|-----------------------|---|
| <b>AVERY DENNISON</b> | FASTENER DIVISION<br>FITCHBURG, MA 01420 U.S.A.<br>TEL. 1-800-225-5913<br>FAX. 978-353-8157 |
|                       | DESCRIPTION   |

|                         |         |
|-------------------------|---------|
| 8" CABLE TIE, INTERMED. |         |
| STOCK NO.               | 08401-0 |
| REV.                    | S       |

5

4

3

2

1

# Mouser Electronics

Authorized Distributor

Click to View Pricing, Inventory, Delivery & Lifecycle Information:

[Avery Dennison:](#)

[08401-0](#)