



ON Semiconductor®

NCL30160 1A LED Driver STR-NCL30160-1A-LED-GEVB

Comment Legend

- Description**
Description of circuit that is intended to be evaluated with this PCB.
- Optional**
Circuits that customer could optionally implement yet do not affect PCB purpose.
- Not Required**
Circuits that support the Strata ecosystem that customer would not implement.

ON Semiconductor		
Title NCL30160 1A LED Driver - STR-NCL30160-1A-LED-GEVB		
Size Custom	Document Number ONSEC-19-019	Rev REV2
Date:	Thursday, November 14, 2019	Sheet 1 of 5

NCL30160 Device Schematic

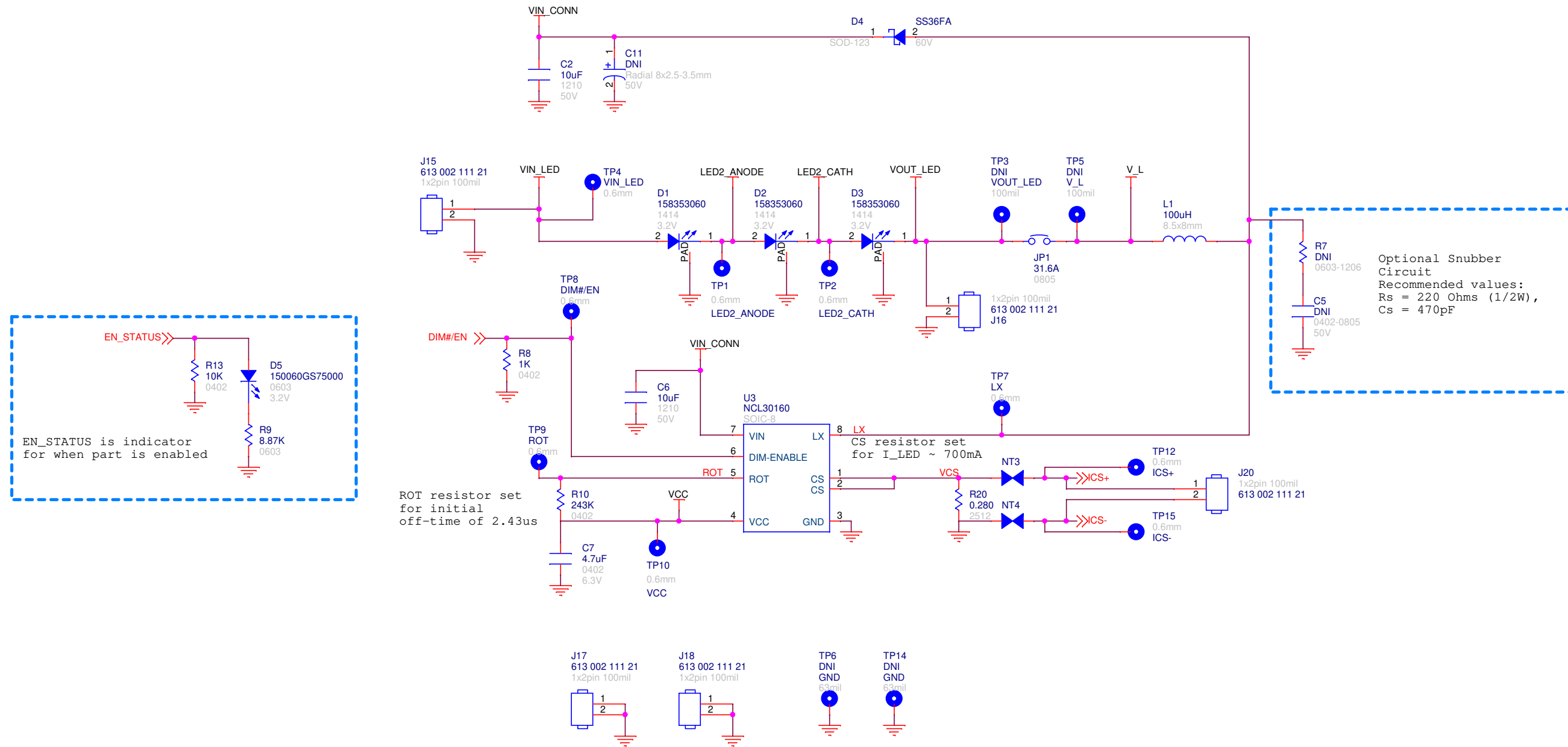

ON Semiconductor		
Title NCL30160 SCHEMATIC - STR-NCL30160-1A-LED-GEVB		
Size Custom	Document Number ONSEC-19-019	Rev REV2
Date: Tuesday, November 19, 2019	Sheet 2	of 5

Telemetry/Control & Connectors

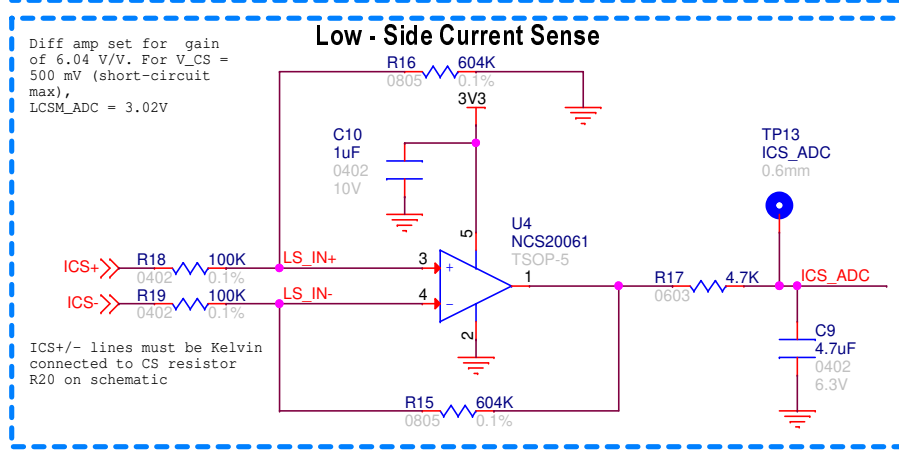
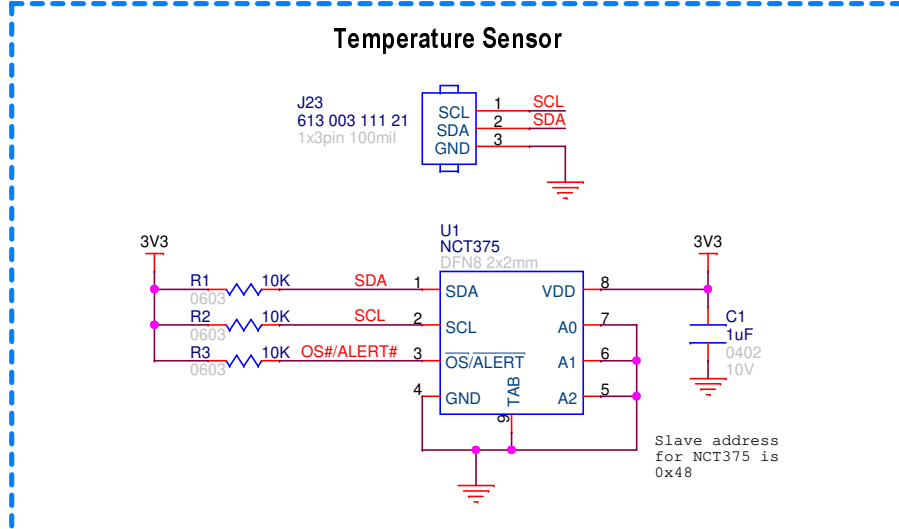
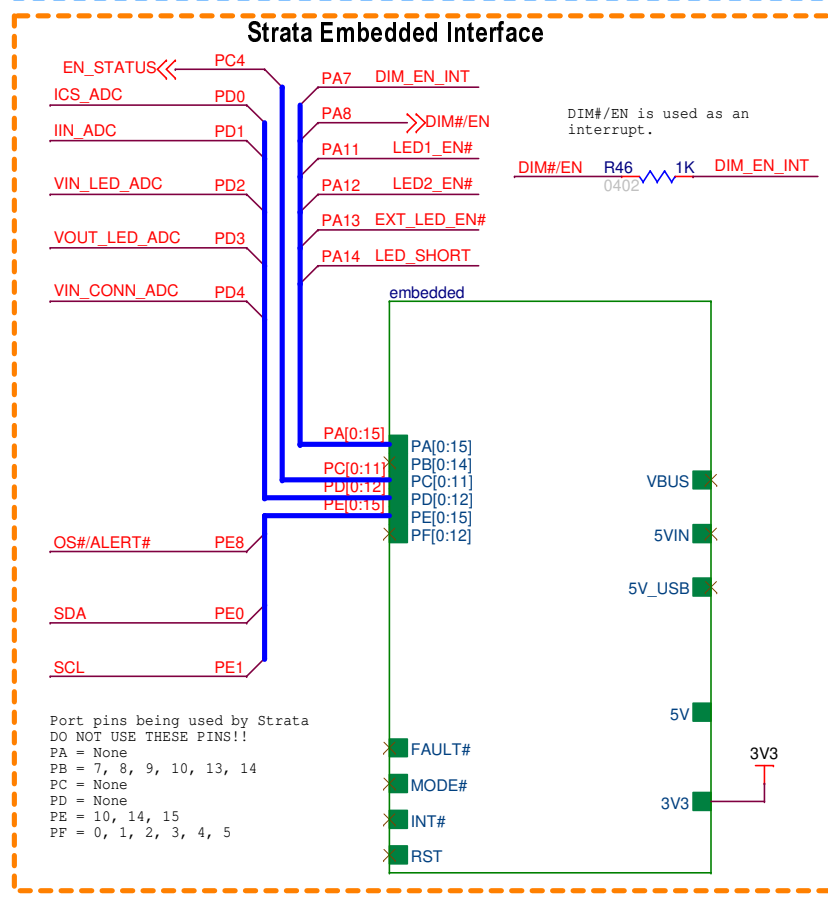
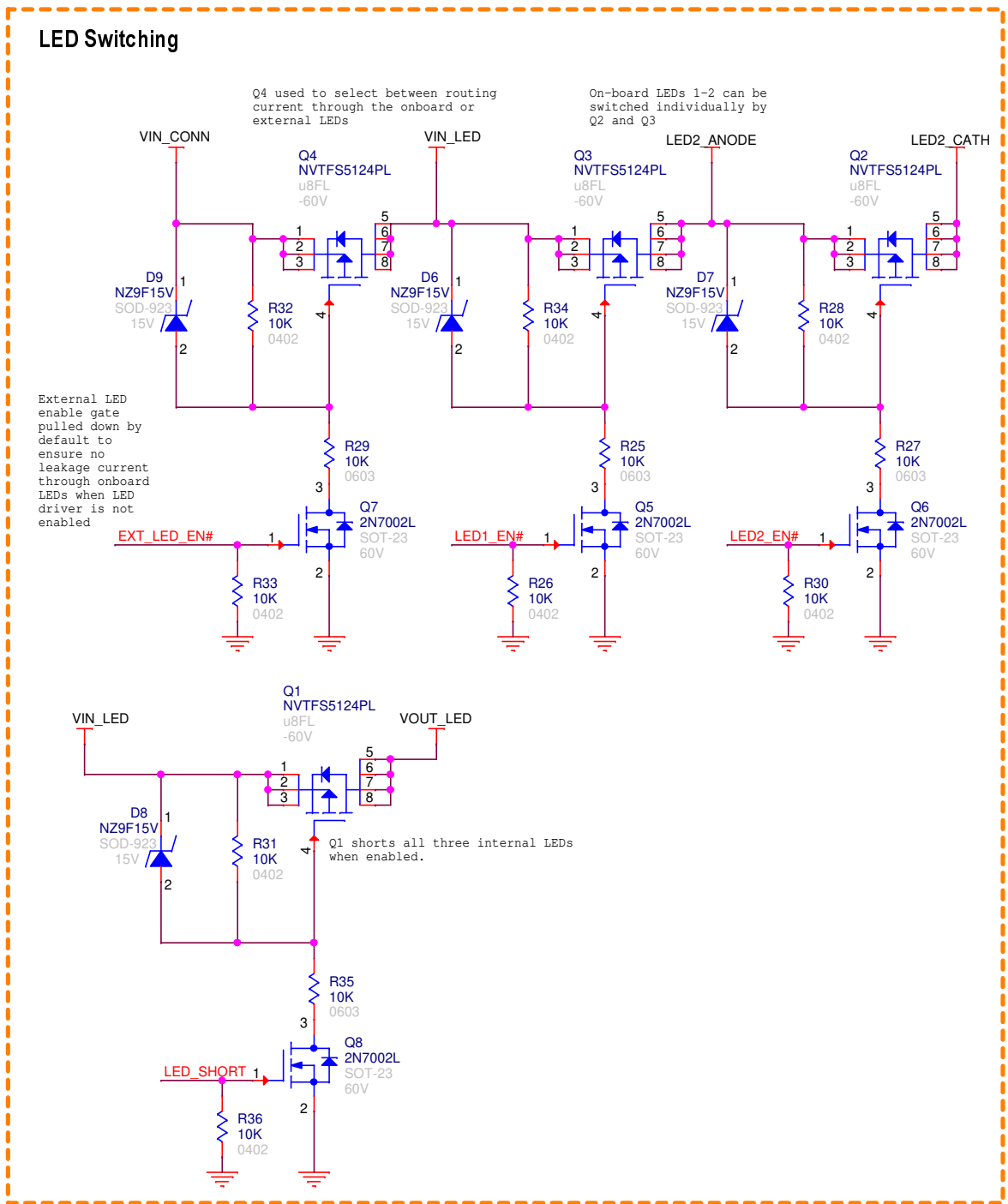
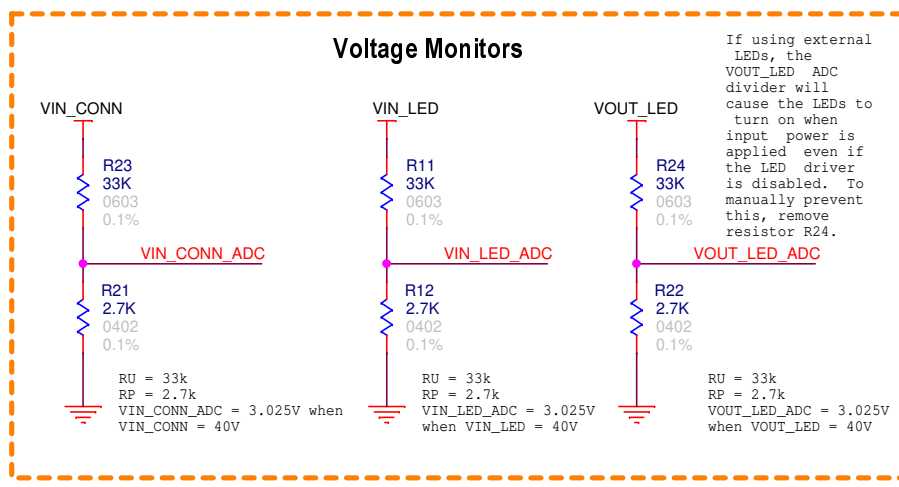
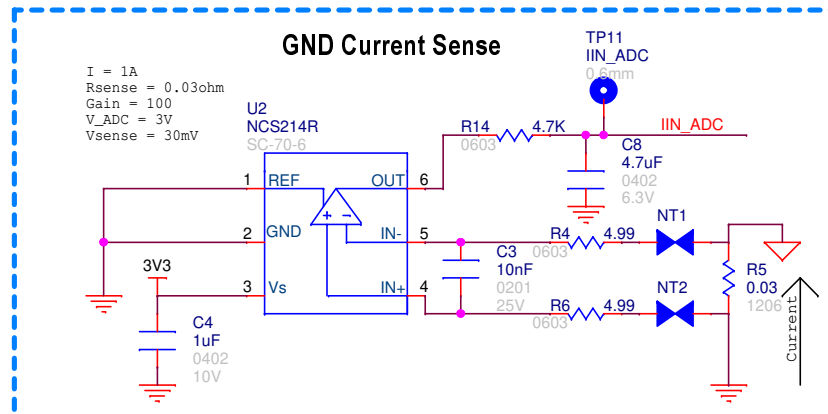
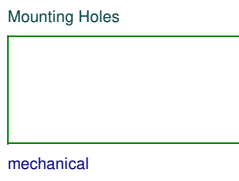
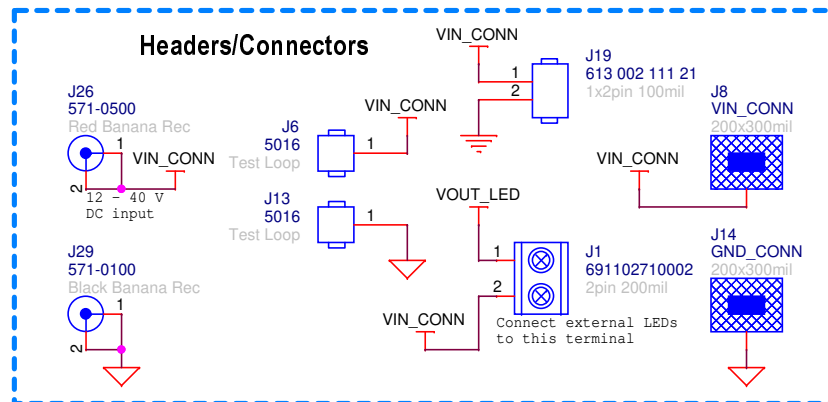

ON Semiconductor		
Title Telemetry/Control & Connectors - STR-NCL30160-1A-LED-GEVB		
Size Custom	Document Number ONSEC-19-019	Rev REV2
Date: Friday, November 15, 2019	Sheet 3	of 5

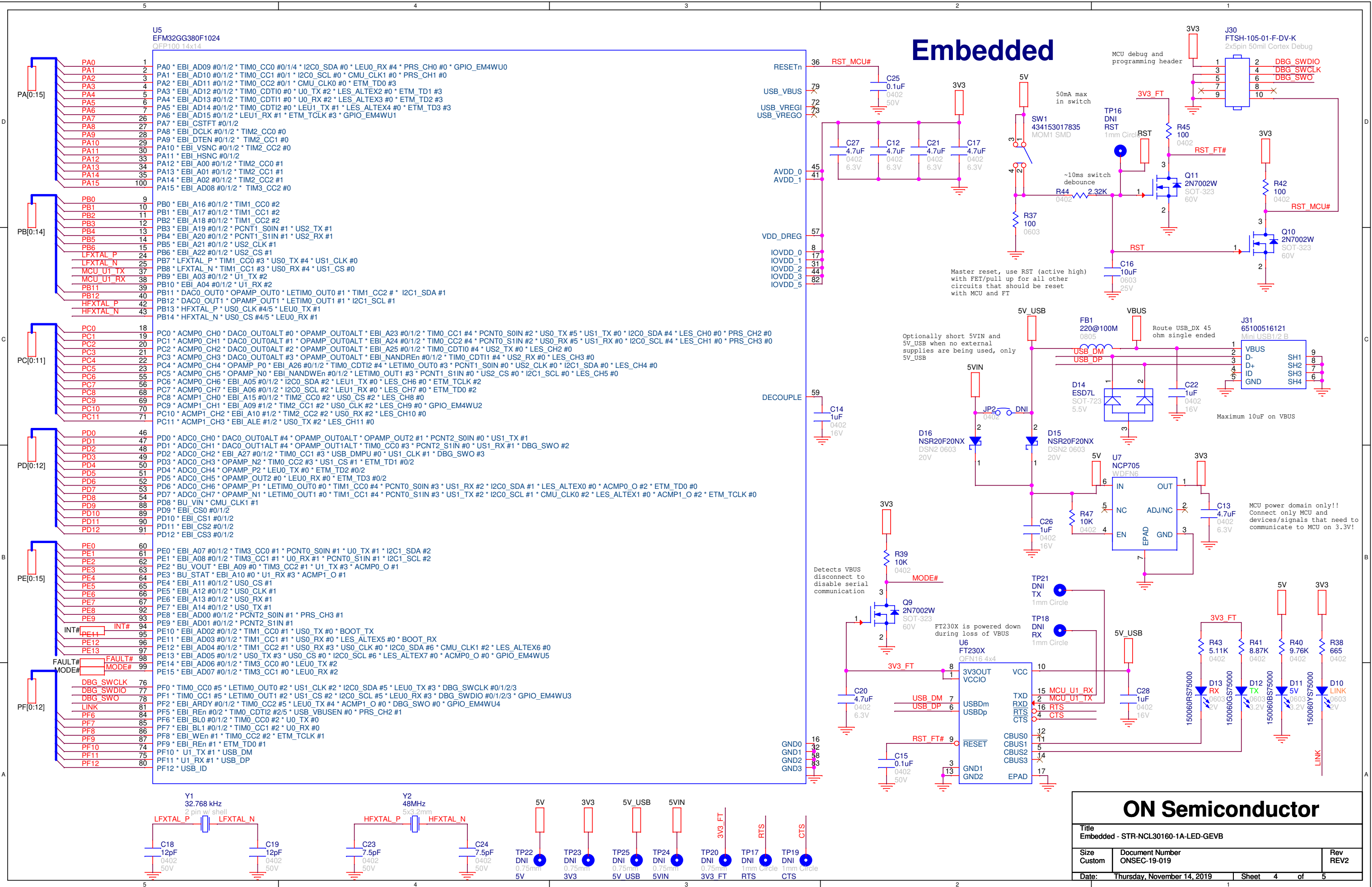

ON Semiconductor		
Title Embedded - STR-NCL30160-1A-LED-GEVB		
Size Custom	Document Number ONSEC-19-019	Rev REV2
Date: Thursday, November 14, 2019	Sheet 4 of 5	

Mechanical

J33
971150365
M3 15MM Standoff



J32
971150365
M3 15MM Standoff



Standoffs

J24
971150365
M3 15MM Standoff



J25
971150365
M3 15MM Standoff



J21
709940300
M3 Nut

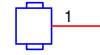

J22
709940300
M3 Nut

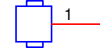

Nuts

J9
970100365
M3 10MM Standoff



J4
970100365
M3 10MM Standoff



J11
970100365
M3 10MM Standoff



J3
970100365
M3 10MM Standoff



J2
97790503211
M3 5MM Screw

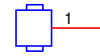

J12
97790503211
M3 5MM Screw

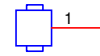

J5
97790503211
M3 5MM Screw



J10
97790503211
M3 5MM Screw



J7
LEDCOVER0
3x1.175"



J27
97790503211
M3 5MM Screw

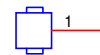

J28
97790503211
M3 5MM Screw



ON Semiconductor

Title
Mechanical - STR-NCL30160-1A-LED-GEVB

Size Custom	Document Number ONSEC-19-019	Rev REV2
----------------	---------------------------------	-------------

Date:	Thursday, November 14, 2019	Sheet	5	of	5
-------	-----------------------------	-------	---	----	---