

isc Silicon NPN Darlington Power Transistor

2SD2165

DESCRIPTION

- High DC Current Gain-
: $h_{FE} = 800(\text{MIN})@ (V_{CE} = 5V, I_C = 1A)$
- Low Collector-Emitter Saturation Voltage
: $V_{CE(sat)} = 1V(\text{MIN})@ (I_C = 3V, I_B = 30mA)$

APPLICATIONS

- Designed for use low frequency amplifier and low switching speed applications.

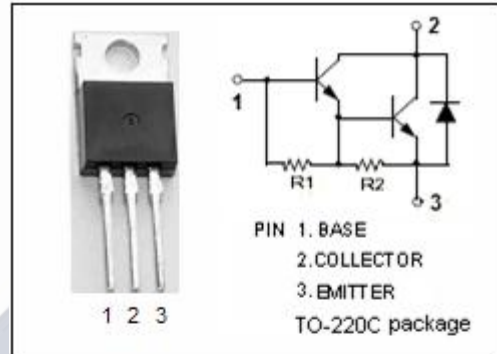

ABSOLUTE MAXIMUM RATINGS($T_a=25^\circ\text{C}$)

SYMBOL	PARAMETER	VALUE	UNIT
V_{CBO}	Collector-Base Voltage	100	V
V_{CEO}	Collector-Emitter Voltage	100	V
V_{EBO}	Emitter-Base Voltage	7	V
I_C	Collector Current-Continuous	6	A
I_{CM}	Collector Current-Peak	10	A
I_B	Base Current-Continuous	1	A
P_C	Collector Power Dissipation @ $T_a=25^\circ\text{C}$	2	W
	Collector Power Dissipation @ $T_c=25^\circ\text{C}$	30	
T_J	Junction Temperature	150	$^\circ\text{C}$
T_{stg}	Storage Temperature	-55~150	$^\circ\text{C}$

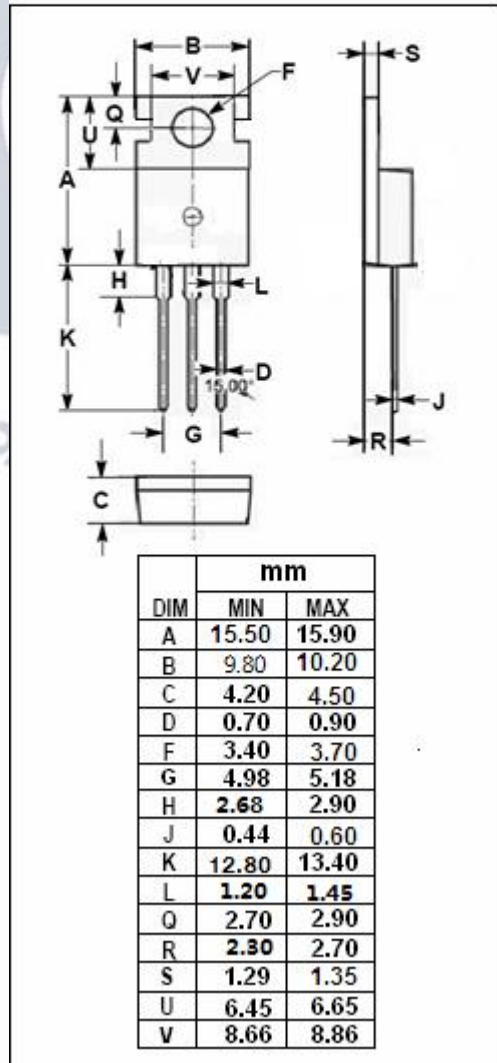

isc Silicon NPN Darlington Power Transistor**2SD2165****ELECTRICAL CHARACTERISTICS**T_j=25°C unless otherwise specified

SYMBOL	PARAMETER	CONDITIONS	MIN	TYP.	MAX	UNIT
V _{CE(sat)}	Collector-Emitter Saturation Voltage	I _C = 3A; I _B = 30mA			1	V
V _{BE(sat)}	Base-Emitter Saturation Voltage	I _C = 3A; I _B = 30mA			1.5	V
I _{CBO}	Collector Cutoff Current	V _{CB} = 60V; I _E = 0			10	μ A
I _{EBO}	Emitter Cutoff Current	V _{EB} = 7V; I _C = 0			10	mA
h _{FE-1}	DC Current Gain	I _C = 1A; V _{CE} = 5V	800		3200	
h _{FE-2}	DC Current Gain	I _C = 3A; V _{CE} = 5V	500			
f _T	Current-Gain—Bandwidth Product	I _C = 0.1A; V _{CE} = 5V		110		MHz
C _{ob}	Output Capacitance	V _{CB} = 10 V, I _E = 0 A, f = 1.0 MHz		50		pF

◆ **h_{FE-1} Classifications**

M	L	K
800-1600	1000-2000	1600-3200