



## 50 to 600 Watts Autoranging, AC-DC Switchers

### Features

- RoHS compliant (VE versions)
- Microcontroller architecture
- Inputs: 115/230 Vac autoranging
- Meets FCC Part 15, EN55022, Class B conducted emissions
- 80 – 90% efficiency
- Any output: 1 to 95V<sub>DC</sub>
- Module enable/disable (except LU series)
- UL, TÜV, CE marked
- Remote sense and current limit
- BUS OK and AC OK (except LU series)
- 40ms ride-through time
- OVP and thermal shutdown
- 1 output; up to 200W
- 1 or 2 outputs; up to 400W
- 1, 2, or 3 outputs; up to 600W

### Product Highlights

If you're looking for the convenience of a complete, low profile, agency-approved switching power supply, look no further. The FlatPAC combines Vicor's workhorse VI-200 family of DC-DC converters with a modular package and front-end subassembly to provide from 50 to 600W of output power from one to three outputs.

A flat plate heat sink for use in conduction cooled applications may be specified as an alternate to the standard finned version by adding "CC" to the end of the model number.

Vicor's FlatPAC is also available with a current controlled output using BatMod converter modules of 12, 24, or 48V<sub>DC</sub> outputs. This option is specified by appending "BM" or "BC" (for conduction cooled versions) to the end of the FlatPAC model number.

Mixing VI-200 and BatMods in a single FlatPAC is not permissible.

The FlatPAC's contemporary design allows us to configure your order quickly and provide rapid turnaround on standard models. It is truly a complete power solution, enabling you to spend more time designing your system and less time worrying about how to power it.

### Configuration Chart

**Typical Model: VI-RU 011-EUUU-:::**

<b>Input</b> 115/230 Vac	<b>Output</b> 1: 5 V <sub>DC</sub> at 200W 2: 12 V <sub>DC</sub> at 200W 3: 12 V <sub>DC</sub> at 200W	<b>Input Characteristics</b> 90–132/180–264 Vac U = Autoranging
-----------------------------	---	---

**Substitute VE– for VI– for RoHS compliant versions**

Configuration	Total Power	# of Converters	Dimensions
<b>Single Output</b>			
VI-LU [ ] - [ ] [ ] [ ]	50 – 200W	1	9.25" x 2.5" x 1.37" (234,8 x 124,5 x 34,8mm)
VI-MU [ ] - [ ] [ ] [ ]	200 – 400W	2	9.25" x 4.9" x 1.37" (234,8 x 124,5 x 34,8mm)
VI-NU [ ] - [ ] [ ] [ ]	300 – 600W	3	9.25" x 7.3" x 1.37" (234,8 x 185,4 x 34,8mm)
<b>Dual Output</b>			
VI-PU [ ] [ ] - [ ] [ ] [ ] [ ]	100 – 400W	2	9.25" x 4.9" x 1.37" (234,8 x 124,5 x 34,8mm)
VI-QU [ ] [ ] - [ ] [ ] [ ] [ ]	150 – 600W	3	9.25" x 7.3" x 1.37" (234,8 x 185,4 x 34,8mm)
<b>Triple Output</b>			
VI-RU [ ] [ ] [ ] - [ ] [ ] [ ] [ ] [ ]	150 – 600W	3	9.25" x 7.3" x 1.37" (234,8 x 185,4 x 34,8mm)

#### • Output Voltage

Z = 2V	W = 5.5V	M = 10V	N = 18.5V	K = 40V	D = 85V
Y = 3.3V	V = 5.8V	1 = 12V	3 = 24V	4 = 48V	B = 95V
0 = 5V	T = 6.5V	P = 13.8V	L = 28V	H = 52V	
X = 5.2V	R = 7.5V	2 = 15V	J = 36V	F = 72V	

#### •• Product Grade Temps. °C

Grade	Operating	Storage
E =	0 to +85	-20 to +100
C =	0 to +85	-20 to +100
I =	-30 to +85	-55 to +100

Temperatures apply to product case.

#### ••• Output Power/Current

V <sub>OUT</sub> ≥ 5V	V <sub>OUT</sub> < 5V
Y = 50W	Y = 10A
X = 75W	X = 15A
W = 100W	W = 20A
V = 150W	V = 30A
U = 200W	U = 40A

#### ••• Output Power/Current

V <sub>OUT</sub> ≥ 5V	V <sub>OUT</sub> < 5V
W = 100W	W = 20A
V = 150W	V = 30A
U = 200W	U = 40A
S = 300W	S = 60A
Q = 400W	Q = 80A

#### ••• Output Power/Current

V <sub>OUT</sub> ≥ 5V	V <sub>OUT</sub> < 5V
S = 300W	S = 60A
P = 450W	P = 90A
M = 600W	M = 120A

#### ••• Options

BC = BatMod/Conduction Cooled      BM = BatMod      CC = Conduction Cooled

## Specifications

(typical at 25°C, nominal line and 75% load, unless otherwise specified)

### INPUT SPECIFICATIONS

Parameter	Min	Typ	Max	Unit	Notes
AC line input					
Autoranging		90 – 132/180 – 264		Vac	
Line frequency		47 – 63 47 – 440		Hz Hz	(C-Grade and E-Grade) (I-Grade)
Inrush current: 115 Vac operation:					
1 converter		16		A	@ peak line
2 converters		23		A	@ peak line
3 converters		39		A	@ peak line
Inrush current: 230 Vac operation					
1 converter		32		A	@ peak line
2 converters		47		A	@ peak line
3 converters		78		A	@ peak line
Ride-through time (full load)					
90/180 Vac low line		5		ms	minimum
115/230 Vac nominal line		40		ms	minimum
AC fail warning time		5		ms	minimum (low line, full load)
AC and BUS OK (2 and 3 converter models only)					
Off state – Vce			70	V	
On state – Vcesat			0.4	V	@ 1mA (1.5mA max.)
Module disable (2 and 3 converter models only, optically isolated LED input)					
Continuous forward current		1 – 30		mA	
Forward voltage			1.65	V	@ 30mA
Dielectric withstand					
Primary to chassis GND		2,121		V <sub>DC</sub>	
Primary to secondary		4,242		V <sub>DC</sub>	
Secondary to chassis GND		707		V <sub>DC</sub>	

### OUTPUT SPECIFICATIONS

Parameter	E-Grade			C-, I-Grade			Unit	Notes
	Min	Typ	Max	Min	Typ	Max		
Set point accuracy		1%	2%		0.5%	1%	V <sub>NOM</sub>	
Load/line regulation			0.5% 1%		0.05% 0.2%	0.2% 0.5%	V <sub>NOM</sub> V <sub>NOM</sub>	LL to HL, 10% to Full Load LL to HL, No Load to full load
Output temperature drift		0.02			0.01	0.02	%/°C	Over rated temperature
Long term drift		0.02			0.02		%/1k hours	
Output ripple								
2V			150mV		60mV	100mV	p-p	20 MHz bandwidth
5V			5%		2%	3%	p-p	20 MHz bandwidth
10 – 48V			3%		0.75%	1.5%	p-p	20 MHz bandwidth
Output voltage trimming <sup>[1]</sup>	50%		110%	50%		110%		
Total remote sense compensation	0.5			0.5			Volts	0.25V max. neg. leg
OVP set point		125%		115%	125%	135%	V <sub>NOM</sub>	Recycle power
Current limit	105%		135%	105%		125%	I <sub>NOM</sub>	Automatic restart
Short circuit current <sup>[2]</sup>	20%		140%	20%		130%	I <sub>NOM</sub>	

## Specifications (Cont.)

### THERMAL CHARACTERISTICS

Parameter	E-Grade			C-, I- Grade			Units	Test Conditions
	Min	Typ	Max	Min	Typ	Max		
Efficiency		78 – 88%			80 – 90%			@ 5V and higher
Shut down temp. — case	90	95	105	90	95	105	°C	Cool and recycle power to restart
Operating temp. — case			85			85	°C	See Thermal Curves

### MECHANICAL SPECIFICATIONS

Parameter	E-Grade			C-, I- Grade			Units	Test Conditions
	Min	Typ	Max	Min	Typ	Max		
Weight <sup>[3]</sup>		22.4 (652)			22.4 (652)		Ounces (Grams)	

### AGENCY APPROVALS

Safety Standards	Markings	Notes
UL1604, UL60950-1	cURus	
UL / CSA / EN / IEC 60950-1	cTÜVus, CE Mark	Low Voltage Directive

### EMI / EMC Characteristics

(Performed on selected samples representative of the U Series FlatPac product family.)

Parameter	Notes
Conducted emissions, LISN	EN 55022 and FCC R&R, Part 15, Subpart B, Class B
Radiated emissions, 10 meters	EN 55022; 1998 and FCC R&R, Part 15, Subpart B, Class A
Electrostatic discharge	IEC 61000-4-2: 1995, Level 4; ±8kV Contact, ± 15kV Air Discharge
RF radiated immunity, E-field	IEC 61000-4-3: 1997; 80MHz to 1.0GHz, 3V/M, CW
Electrical fast transients/burst	EN 61000-4-4: 1995, Level 3; ±2kV,
Surge immunity	EN 61000-4-5: 1996 Class 3; ±2kV Line to Ground, ±1kV Line to Line
RF conducted immunity	IEC 61000-4-6: 1996, class 3, 10V <sub>RMS</sub> , 150kHz to 80MHz
Power frequency magnetic field immunity	IEC 61000-4-8: 1994, 30 to 300 A/M, 50Hz
Voltage dips and interrupts	IEC 61000-4-11: 1994

[1] 10V to 15V outputs, trim range ± 10%. Consult factory for wider trim range.

[2] Output voltages of 5V or less incorporate foldback current limiting, outputs greater than 5V incorporate straight line current limiting.

[3] For MU, PU series, multiply value by 2; for NU, QU, RU series, multiply value by 3.

## Thermal Curves

FREE AIR  
  50 LFM  
  100 LFM  
  250 LFM  
  500 LFM  
  750 LFM  
  1000 LFM

### 5V Output

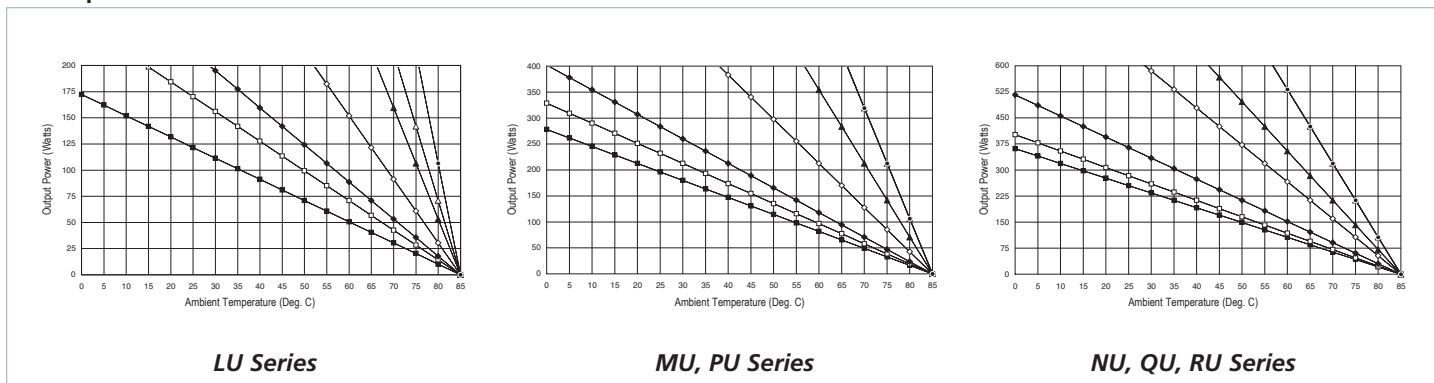

### 10 to 48V Output

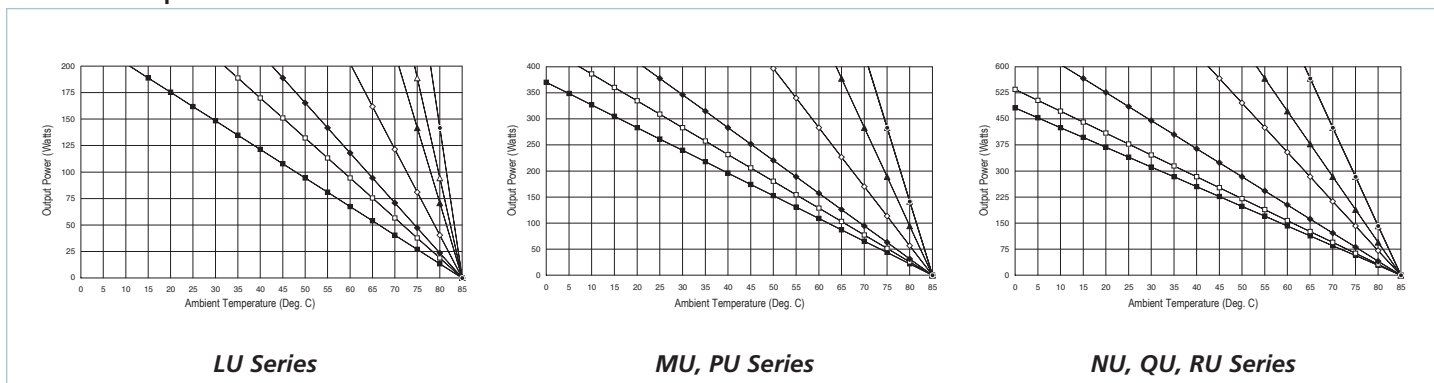

## Application Circuits

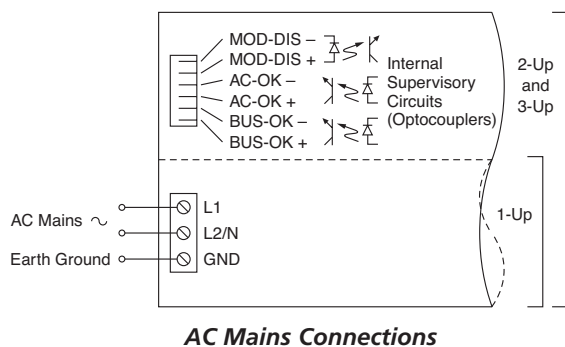

AC Mains Connections

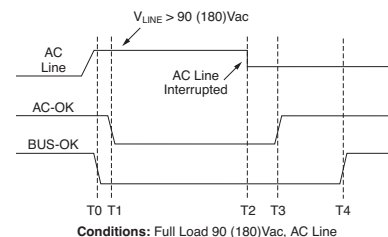

Time Interval	Min	Typ	Max	Units	Notes
T0-T1	0	0.1	1.0	ms	
T2-T3	0	40	-	ms	Ride-through time
T2-T4	5	-	-	ms	Hold-up time
T3-T4	5	-	-	ms	AC fail warning time

### Power Up and Power Down Sequencing

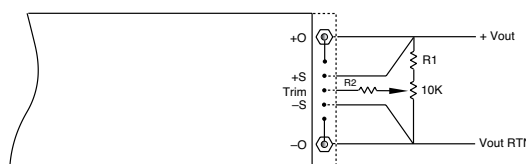

### Resistor Values for Trimming Standard Output Voltages

Nom. Output Voltage	5V	12V	15V	24V	28V	48V	Trim Range
R1(kΩ)	0.953	15.8	22.1	41.2	48.7	90.9	+10%, -10%
R2(kΩ)	90	90	90	90	90	90	

### Output Trimming

Mechanical Drawings

- Inputs**
- 1 MOD DIS-
  - 2 MOD DIS+
  - 3 AC OK-
  - 4 AC OK+
  - 5 BUS OK-
  - 6 BUS OK+
  - 7 AC IN L1
  - 8 AC IN L2/N
  - 9 CHASSIS GND
- Input connector, Amp P/N 644488-6; mating connector, MTA-100 IDC Series
- Terminals for #16-12 AWG wire

- Outputs**
- 10 +OUT (#10-32 Stud)
  - 11 +OUT
  - 12 +SENSE ( $V_{TRIM}^*$ )
  - 13 TRIM ( $I_{TRIM}^*$ )
  - 14 -SENSE ( $I_{MON}^*$ )
  - 15 -OUT
  - 16 -OUT (#10-32 Stud)
- Output connector, Amp P/N 644486-5; mating connector, MTA-100 IDC Series

\*On FlatPACs with BatMODs only.

STANDARD Models

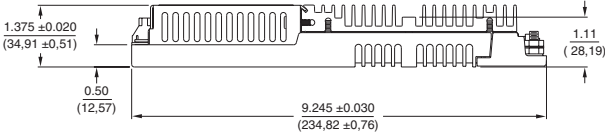

CONDUCTION COOLED Models "-CC"

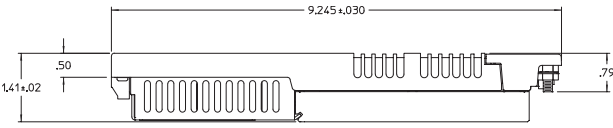

LU Series

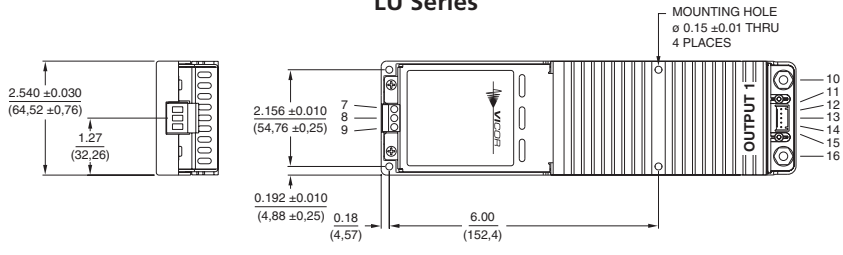

MU Series

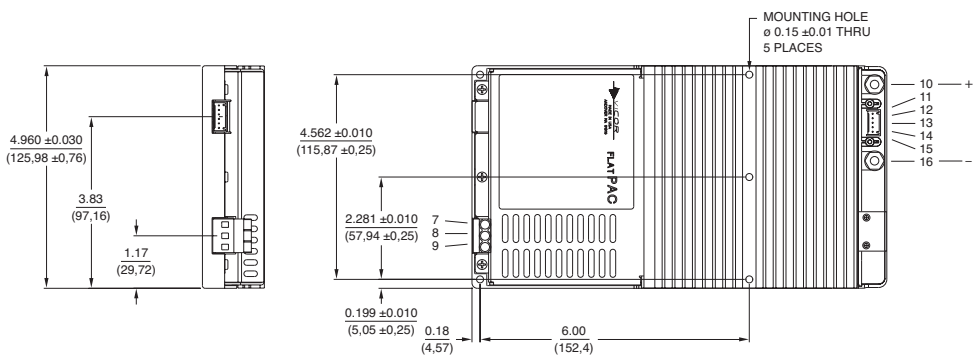

PU Series

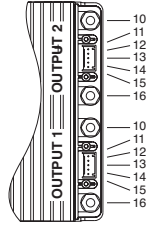

NU Series

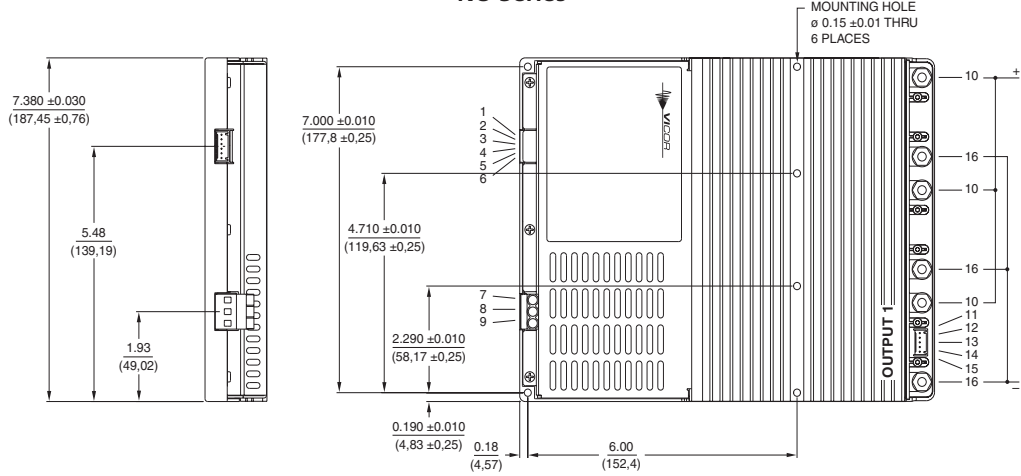

QU Series

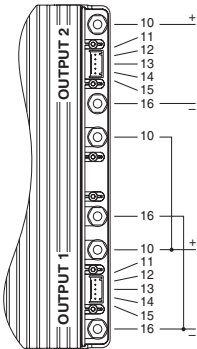

RU Series

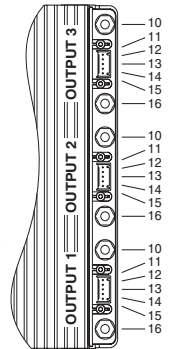

---

## **Vicor's comprehensive line of power solutions includes high density AC-DC and DC-DC modules and accessory components, fully configurable AC-DC and DC-DC power supplies, and complete custom power systems.**

Information furnished by Vicor is believed to be accurate and reliable. However, no responsibility is assumed by Vicor for its use. Vicor makes no representations or warranties with respect to the accuracy or completeness of the contents of this publication. Vicor reserves the right to make changes to any products, specifications, and product descriptions at any time without notice. Information published by Vicor has been checked and is believed to be accurate at the time it was printed; however, Vicor assumes no responsibility for inaccuracies. Testing and other quality controls are used to the extent Vicor deems necessary to support Vicor's product warranty. Except where mandated by government requirements, testing of all parameters of each product is not necessarily performed.

**Specifications are subject to change without notice.**

### **Vicor's Standard Terms and Conditions**

All sales are subject to Vicor's Standard Terms and Conditions of Sale, which are available on Vicor's webpage or upon request.

### **Product Warranty**

In Vicor's standard terms and conditions of sale, Vicor warrants that its products are free from non-conformity to its Standard Specifications (the "Express Limited Warranty"). This warranty is extended only to the original Buyer for the period expiring two (2) years after the date of shipment and is not transferable.

UNLESS OTHERWISE EXPRESSLY STATED IN A WRITTEN SALES AGREEMENT SIGNED BY A DULY AUTHORIZED VICOR SIGNATORY, VICOR DISCLAIMS ALL REPRESENTATIONS, LIABILITIES, AND WARRANTIES OF ANY KIND (WHETHER ARISING BY IMPLICATION OR BY OPERATION OF LAW) WITH RESPECT TO THE PRODUCTS, INCLUDING, WITHOUT LIMITATION, ANY WARRANTIES OR REPRESENTATIONS AS TO MERCHANTABILITY, FITNESS FOR PARTICULAR PURPOSE, INFRINGEMENT OF ANY PATENT, COPYRIGHT, OR OTHER INTELLECTUAL PROPERTY RIGHT, OR ANY OTHER MATTER.

This warranty does not extend to products subjected to misuse, accident, or improper application, maintenance, or storage. Vicor shall not be liable for collateral or consequential damage. Vicor disclaims any and all liability arising out of the application or use of any product or circuit and assumes no liability for applications assistance or buyer product design. Buyers are responsible for their products and applications using Vicor products and components. Prior to using or distributing any products that include Vicor components, buyers should provide adequate design, testing and operating safeguards.

Vicor will repair or replace defective products in accordance with its own best judgment. For service under this warranty, the buyer must contact Vicor to obtain a Return Material Authorization (RMA) number and shipping instructions. Products returned without prior authorization will be returned to the buyer. The buyer will pay all charges incurred in returning the product to the factory. Vicor will pay all reshipment charges if the product was defective within the terms of this warranty.

### **Life Support Policy**

VICOR'S PRODUCTS ARE NOT AUTHORIZED FOR USE AS CRITICAL COMPONENTS IN LIFE SUPPORT DEVICES OR SYSTEMS WITHOUT THE EXPRESS PRIOR WRITTEN APPROVAL OF THE CHIEF EXECUTIVE OFFICER AND GENERAL COUNSEL OF VICOR CORPORATION. As used herein, life support devices or systems are devices which (a) are intended for surgical implant into the body, or (b) support or sustain life and whose failure to perform when properly used in accordance with instructions for use provided in the labeling can be reasonably expected to result in a significant injury to the user. A critical component is any component in a life support device or system whose failure to perform can be reasonably expected to cause the failure of the life support device or system or to affect its safety or effectiveness. Per Vicor Terms and Conditions of Sale, the user of Vicor products and components in life support applications assumes all risks of such use and indemnifies Vicor against all liability and damages.

### **Intellectual Property Notice**

Vicor and its subsidiaries own Intellectual Property (including issued U.S. and Foreign Patents and pending patent applications) relating to the products described in this data sheet. No license, whether express, implied, or arising by estoppel or otherwise, to any intellectual property rights is granted by this document. Interested parties should contact Vicor's Intellectual Property Department.

#### **Vicor Corporation**

25 Frontage Road  
Andover, MA, USA 01810  
Tel: 800-735-6200  
Fax: 978-475-6715

#### **email**

Customer Service: [custserv@vicorpower.com](mailto:custserv@vicorpower.com)  
Technical Support: [apps@vicorpower.com](mailto:apps@vicorpower.com)

# Mouser Electronics

Authorized Distributor

Click to View Pricing, Inventory, Delivery & Lifecycle Information:

## Vicor:

[VI-QUB3-CSV](#) [VI-LUY-CU](#) [VI-MU4-1Q](#) [VI-MU4-IQ](#) [VI-PU03-EYU](#) [VI-QU32-CQU](#) [VI-PU22-EXX](#) [VI-NU3-EM](#) [vi-mu3-eq](#) [VE-PU30-EUY](#) [VI-MU3-EQ](#) [VI-MUF-EQ](#) [VI-MU3-ES](#) [VI-NU2-EM](#) [VI-LU1-EU](#) [VI-RU031-EWWX](#) [VE-PU31-IWW](#) [VI-NUL-EM](#) [VI-LU3-EW](#) [VI-PULL-EUU](#) [VI-PU11-EWW](#) [VI-PUFF-EVV](#) [VI-RU013-CYYW](#) [VI-LUL-IU-CC](#) [VI-QUB3-ISU](#) [VI-MUL-ES](#) [VI-QU33-EQU](#) [VI-RU010-EYYY](#) [VI-RU000-EWWW](#) [VI-LUF-EW](#) [VI-QU33-EQW](#) [VI-PU03-EWW](#) [VI-RU011-CVYY](#) [VI-LU1-CU](#) [VI-PU03-EYW](#) [VI-PU33-EUU](#) [VI-LU3-EU](#) [VI-PU33-EVV](#) [VE-LU1-CU](#) [VE-LU3-EU](#) [VI-PUKK-CWW](#) [VI-NUP-EM](#) [VI-LUJ-EU](#) [VI-RU333-CVVV](#) [VI-MU4-EQ](#) [VI-PU03-EYX](#) [VI-RU00Z-EVXY](#) [VI-PU44-EYY](#) [VI-PU3J-IVY](#) [VI-PUM0-EXY](#) [VI-RU033-CUWY](#) [VI-PU3L-EWX](#) [VI-RU330-CXXY](#) [VI-RUBBB-CUUU](#) [VI-PU10-EYU](#) [VI-RU310-IUVV](#) [VI-PU4L-EUV](#) [VI-PUL1-CUX](#) [VI-RU1L0-IVYY](#) [VI-QU11-IQU](#) [VI-RU143-CUWV](#) [VI-PU3V-CWX](#) [VI-RU100-CWWW](#) [VI-PU03-EXX](#) [VI-PUM2-CYY](#) [VI-RU003-CUUX](#) [VI-QU43-ISU](#) [VI-PUT3-EWW](#) [VI-PUY2-EUU-LL](#) [VI-RU022-EVXX](#) [VI-QUD1-EQY](#) [VI-PU30-CUW](#) [VI-RU444-EUUU](#) [VI-RU22L-CUUU](#) [VI-RUL22-EYYY](#) [VI-PU13-EUU-BM](#) [VI-RU002-EYYX](#) [VI-QU1L-IQW](#) [VI-RUJ03-EUYV](#) [VI-RUF30-EWUY](#) [VI-PUDD-EYY](#) [VI-PU41-CWU](#) [VI-PU33-EXY](#) [VI-RU310-CYWY](#) [VI-PU11-CVY](#) [VI-RUY03-CYYY](#) [VI-RU1N3-EWYW](#) [VI-QU01-IQU](#) [VI-QU2Y-ESW-LL](#) [VI-PUHH-CUU](#) [VI-RU01L-IYWU-CC](#) [VI-PU22-IXX](#) [VI-RU003-IXYW](#) [VI-RU0NN-EYUU](#) [VI-PU0M-EUU](#) [VI-PU0D-IWY](#) [VI-PU2X-IYY](#) [VI-RU110-IWWU](#) [VI-PU03-EVU](#) [VI-RU0ZT-CVYY](#)