

THIS DRAWING IS UNPUBLISHED. RELEASED FOR PUBLICATION
 © COPYRIGHT BY TYCO ELECTRONICS CORPORATION. ALL INTERNATIONAL RIGHTS RESERVED.

LOC	DIST	REVISIONS					
G	14	P	LTR	DESCRIPTION	DATE	DWN	APVD
		F		REV PER ECR 09-002518	04FEB09	JR	TM

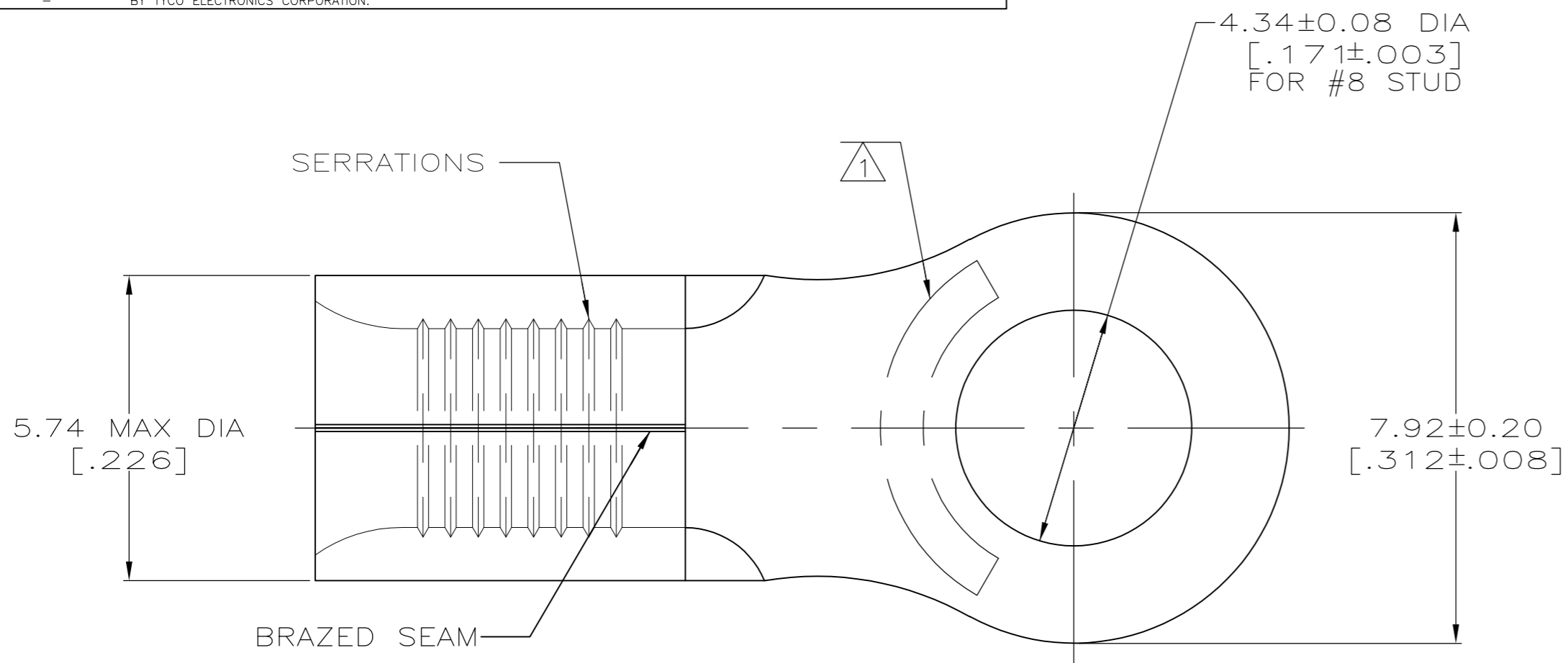

AMP WIRE RANGE	Listed FILE E13288	LR7189 Certified
12-10 AWG SOLID OR STRANDED	12-10 AWG STRANDED	12-10 AWG SOLID OR STRANDED

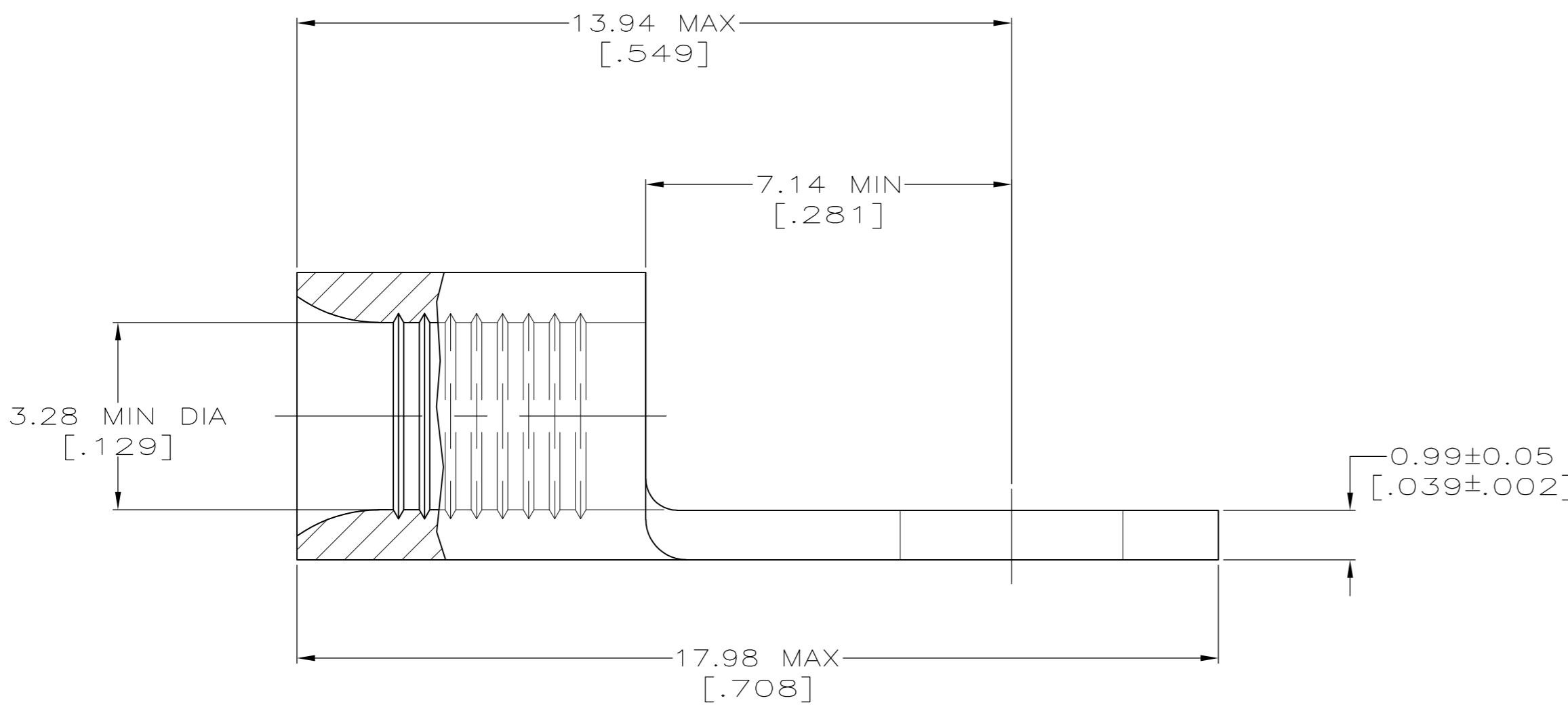

- ① STAMP AMP 12-10* APPROX AS SHOWN
- ② PRELIMINARY - NOT FOR PRODUCTION
- ③ 0.00254 [.000100] MIN TIN PLATE PER ASTM B-545
- ④ CLEANED, UNPLATED
- ⑤ 0.00254 [.000100] MIN TIN-LEAD (93-7) PLATE PER ASTM B-545 (3% MIN LEAD CONTENT)
- ⑥ COPPER PER ASTM B-152, ANNEALED

⑤	500	LOOSE PIECE	322454-3
④	-	LOOSE PIECE	② 322454-2
③	50	LOOSE PIECE, BOX	8-322454-2
③	2500	ON TAPE, REEL	322454-1
③	----	LOOSE PIECE	322454
FINISH	QTY	PACKAGE TYPE	PART NO.

MAX RECOMMENDED OPERATING TEMPERATURE: 170°C MAX	THIS DRAWING IS A CONTROLLED DOCUMENT.		DWN TA BRINKMAN 3-17-93	Tyco Electronics Corporation Harrisburg, PA 17105-3608
	VOLTAGE RATING: N/A	DIMENSIONS: MM [INCHES]	CHK DA PATTERSON 3-17-93	
CIRCULAR MIL AREA: 2.62-6.64mm² [5,180-13,100] SOLID OR STRANDED		TOLERANCES UNLESS OTHERWISE SPECIFIED:	APVD 3-17-93	PRODUCT SPEC
		MATERIAL ⑥	FINISH SEE TABLE	APPLICATION SPEC
			WEIGHT -	SIZE A2
			CUSTOMER DRAWING	CAGE CODE 00779
				DRAWING NO 322454
				RESTRICTED TO -
				SCALE 10:1
				SHEET 1 of 1
				REV F

322454