

THIS DRAWING IS UNPUBLISHED. RELEASED FOR PUBLICATION  
 © COPYRIGHT BY TYCO ELECTRONICS CORPORATION. ALL RIGHTS RESERVED.

LOC	DIST	REVISIONS					
		P	LTR	DESCRIPTION	DATE	DWN	APVD
H	-		K	ECR-07-008767	16-07-07	BSV	KMA
			K1	ECR-08-003235	16-05-08	AEG	KMA
			M	ECR-09-004273	02-03-09	AEG	KMA

NOTES:

- THIS PLUG ACCEPTS SIZE 20 PIN CONTACTS.
- MAXIMUM WIRE INSULATION RECOMMENDED FOR USE WITH THIS PLUG IS 1,73 DIA. MAX..
- RETENTION TINES ARE AN INTEGRAL PART OF INSERT.
- FOLLOWING INSERTION/REMOVAL TOOLS ARE RECOMMENDED FOR USE WITH THESE CONNECTORS:
 

32-28AWG/28-24AWG CONT's	24-20AWG CONTACTS
91067-3 INSERTION/REMOVAL	91067-2 INSERTION/REMOVAL
726363-1 INSERTION ONLY	726363-1 INSERTION ONLY
	726364-1 REMOVAL ONLY
- CONTACTS SHOWN FOR ILLUSTRATION ONLY, NO PART OF CONNECTOR PACKAGE ;MUST BE ORDERED SEPARATELY.
- RAISED CAVITY IDENTIFICATION NUMBERS ON WIRE SIDE ARE WHITENED FOR -9 P/N'S.

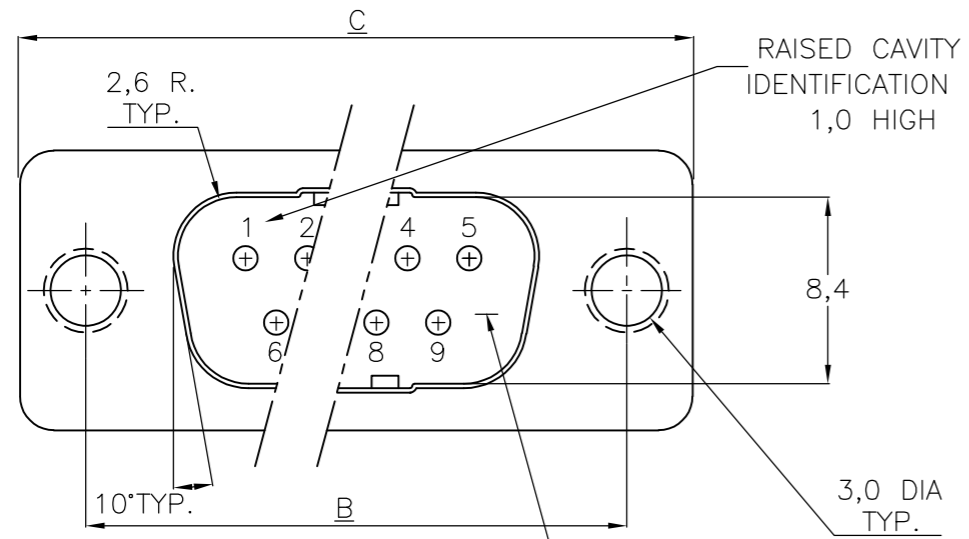

SIZE 1 THRU 4 CONFIGURATION

MATING FACE

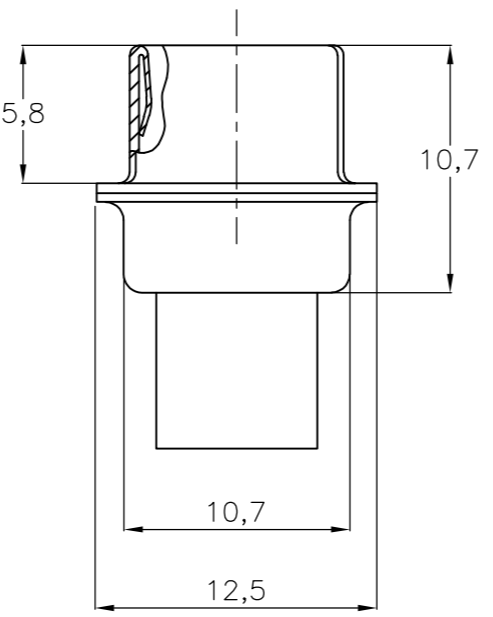
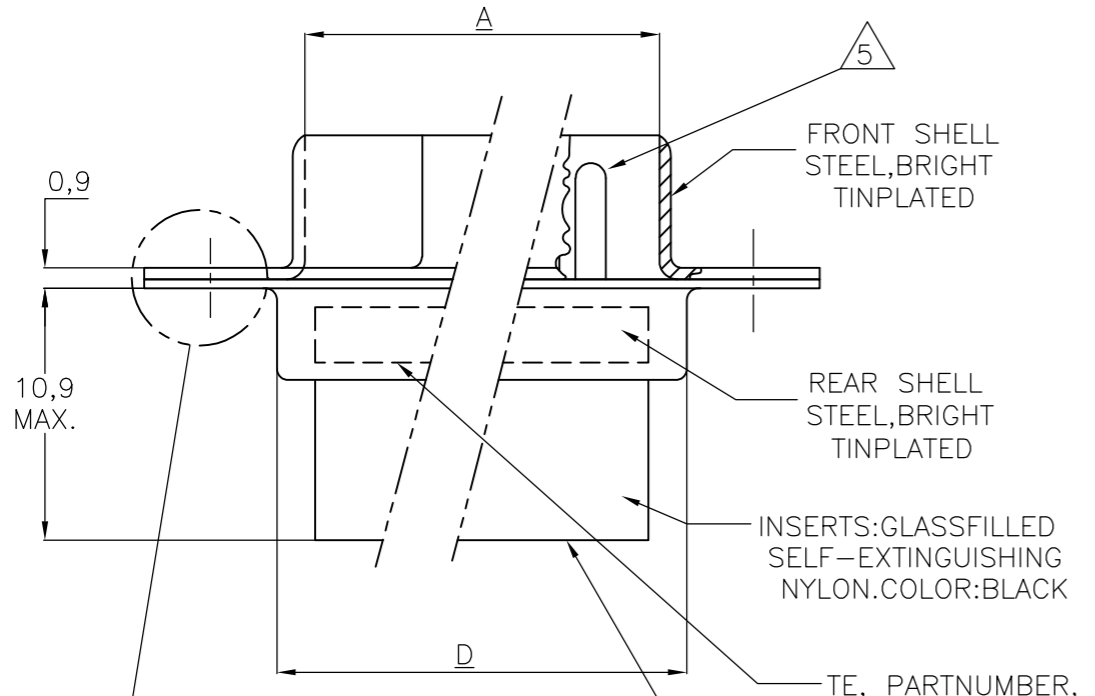

D	C	B	A	NR.OF POS	SIZE	TE ORDER NUMBER
55,3	66,9	61,1	52,9	50	5	<del>167296-9</del> 167296-1
57,7	69,3	63,5	55,4	37	4	<del>167295-9</del> 167295-1
41,3	53,0	47,0	39,0	25	3	<del>167294-9</del> 167294-1
27,5	39,1	33,3	25,3	15	2	<del>167293-9</del> 167293-1
19,3	30,8	25,0	16,9	9	1	<del>167292-9</del> 167292-1

FOR DETAILS SIZE 5, SEE SHEET 2.

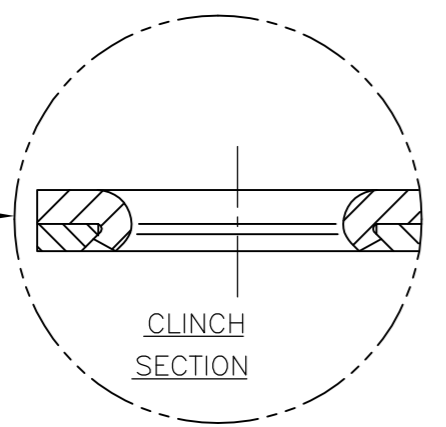

CLINCH SECTION

6

THIS DRAWING IS A CONTROLLED DOCUMENT.		DWN B.MOOIJ 20NOV87	Tyco Electronics Tyco Electronics Corporation 's-Hertogenbosch, Nederland	
DIMENSIONS: mm		CHK -	NAME	
TOLERANCES UNLESS OTHERWISE SPECIFIED:		APVD -	HDP-20 PLUG CONNECTOR, SIZE 1-4	
0 PLC ± -	1 PLC ± -	PRODUCT SPEC -	SIZE	CAGE CODE
2 PLC ± -	3 PLC ± -	APPLICATION SPEC -	DRAWING NO	
4 PLC ± -	ANGLES ± -	WEIGHT -	RESTRICTED TO	
MATERIAL -	FINISH -	A300779		C-167292
CUSTOMER DRAWING			SCALE NTS	SHEET 1 OF 2
			REV M	

THIS DRAWING IS UNPUBLISHED. RELEASED FOR PUBLICATION  
 © COPYRIGHT BY TYCO ELECTRONICS CORPORATION. ALL RIGHTS RESERVED.

LOC	DIST	REVISIONS			
P	LTR	DESCRIPTION	DATE	DWN	APVD
H	—	SEE SHEET 1	—	—	—

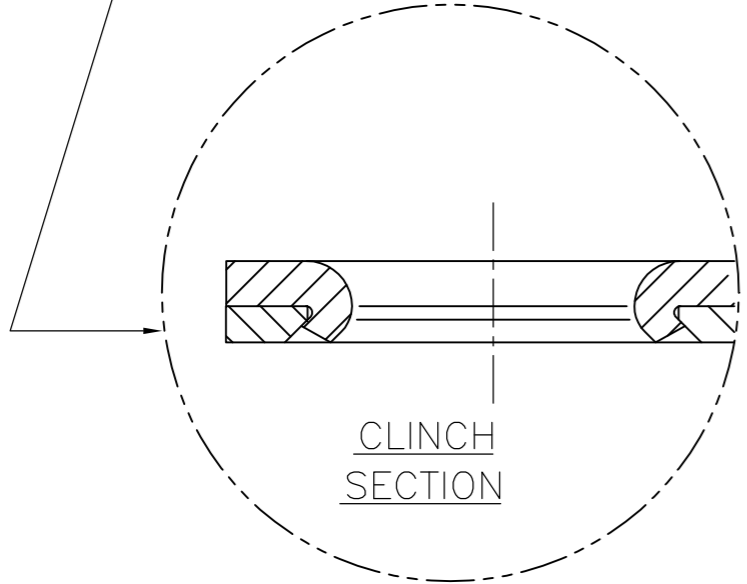
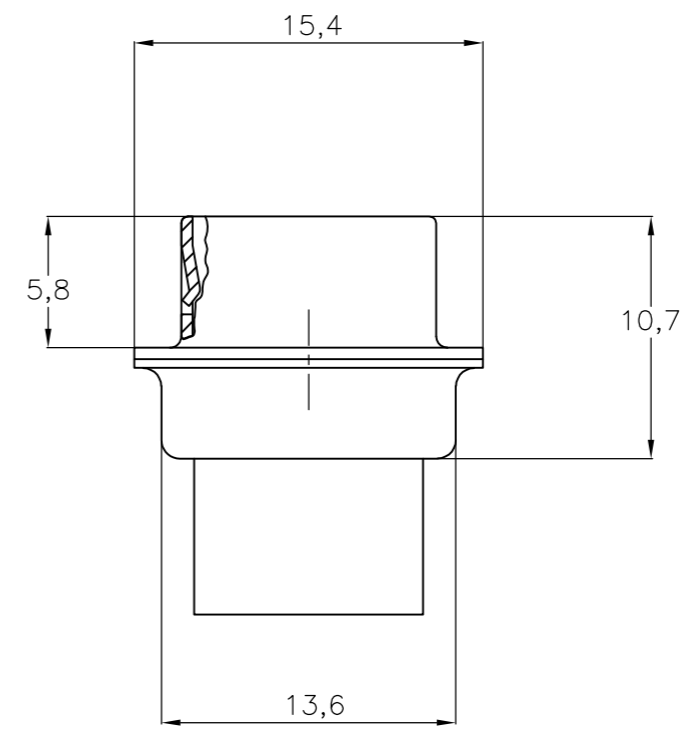
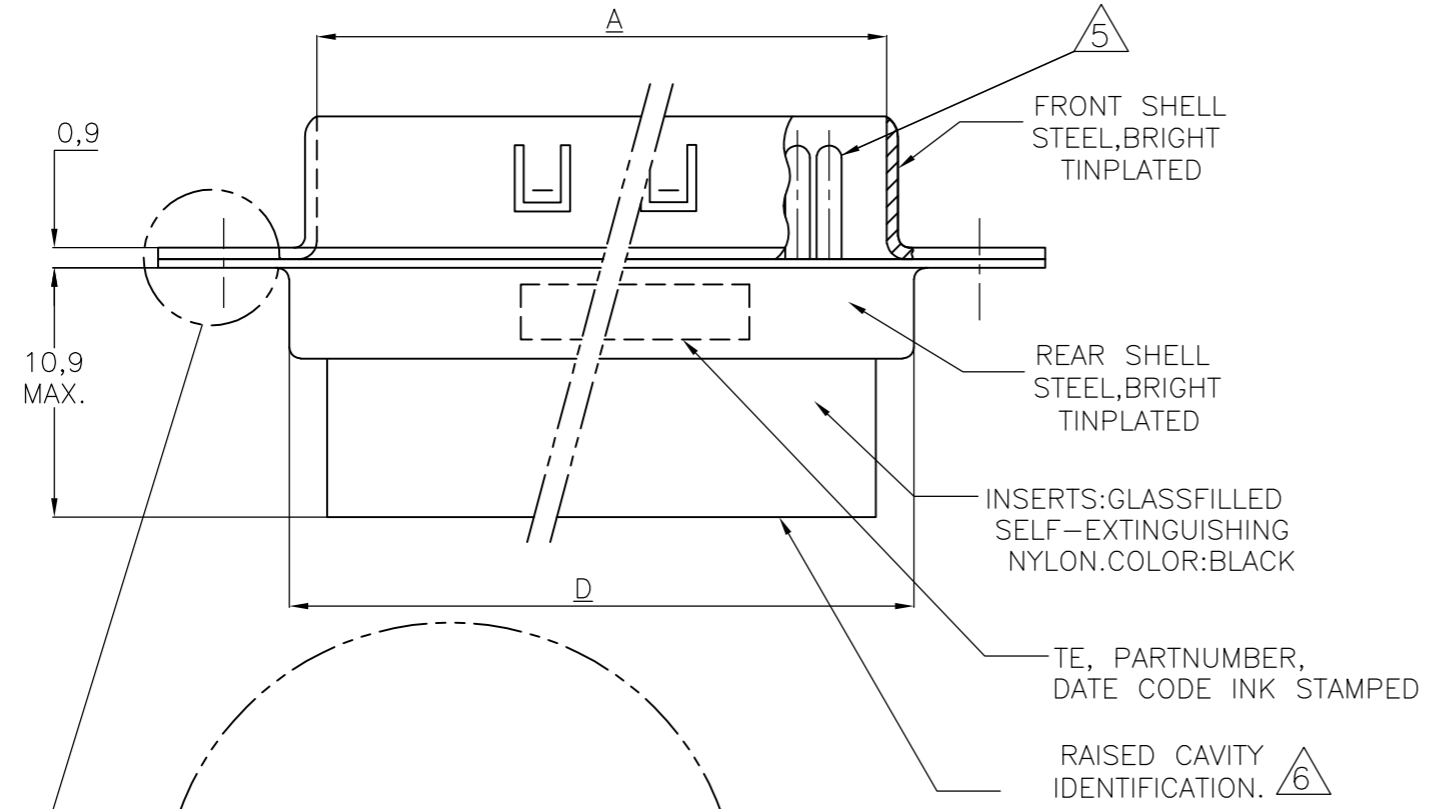
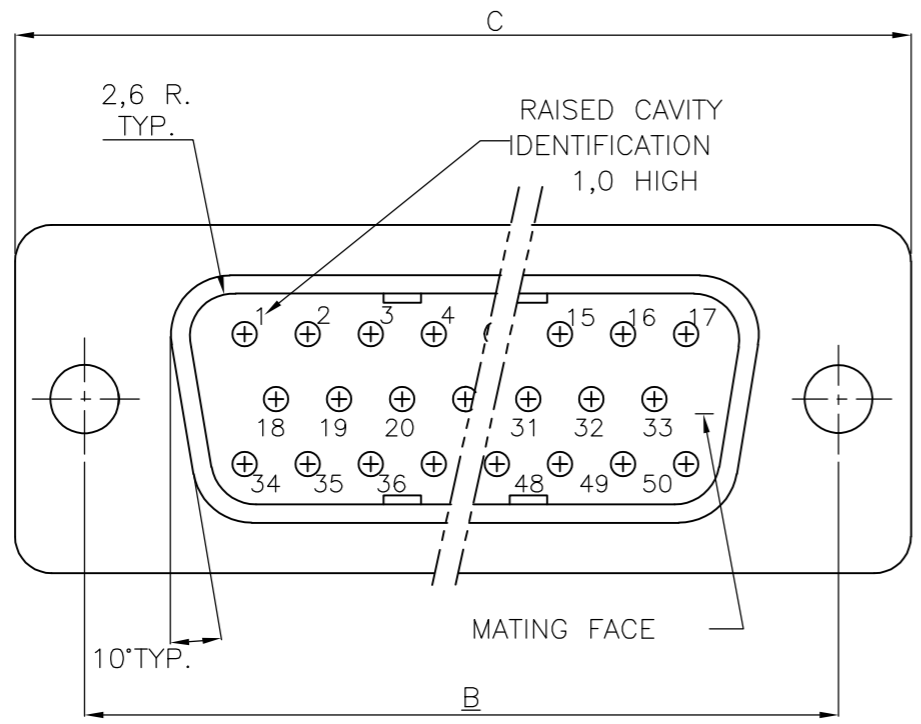

THIS DRAWING IS A CONTROLLED DOCUMENT.		DWN B.MOOIJ 20NOV87	Tyco Electronics Corporation 's-Hertogenbosch, Nederland	
DIMENSIONS: mm		CHK —	NAME HDP-20 PLUG CONNECTOR, SIZE 5	
TOLERANCES UNLESS OTHERWISE SPECIFIED:		APVD —	SIZE A3	
0 PLC ± -	1 PLC ± -	PRODUCT SPEC —	CAGE CODE 00779	DRAWING NO C-167292
2 PLC ± -	3 PLC ± -	APPLICATION SPEC —	RESTRICTED TO —	
4 PLC ± -	ANGLES ± -	WEIGHT —	SCALE NTS SHEET 2 OF 2 REV M	
MATERIAL —	FINISH —	CUSTOMER DRAWING		