



This board assembly 'breaks out' the 5 x 7 pins of the eRIC RF Transceiver to a more convenient 2 x 12 x 0.1" pitch DIL pinout that matches commercial prototype breadboards. This allows the quick and easy testing and evaluation of eRIC modules for which these boards are intended.

The board is supplied with either an eRIC4 or eRIC9 module fitted together with a matching 434MHz or an 868/915 MHz antenna.

Pin	Function	Pin	Function
1	Carrier Detect	23	RF Gnd
2	Busy	22	GPIO
3	SDO	21	GPIO
4	SDI	20	GPIO
5	Host Ready	19	GPIO
6	Vcc - 3.3V	18	GPIO
7	0V Gnd	17	GPIO
8	JTag	16	GPIO
9	Reset	15	GPIO
10	GPIO	13	GPIO
11	GPIO	14	Frequency Select (eRIC9 only)
12	GPIO	GND	0V Gnd

Antenna connection is via an SMA Jack connector or alternatively the on-board eRIC UFL RF connector.

A supplied jumper optionally connects the eRIC Frequency Select Pin (14) to 0V Gnd setting the eRIC9 version module to a base operating frequency of 915MHz and restricting operation to meet FCC (USA) requirements.

### Specifications

Temperature 20°C

Mechanical	Typical	Units	Notes
Size	67 x 20 x 5	mm	Excluding antenna connector
Pinout	12 x 2 DIL on 0.5" pitch		
Pin pitch	0.1	Inch	2.54mm

## Schematic

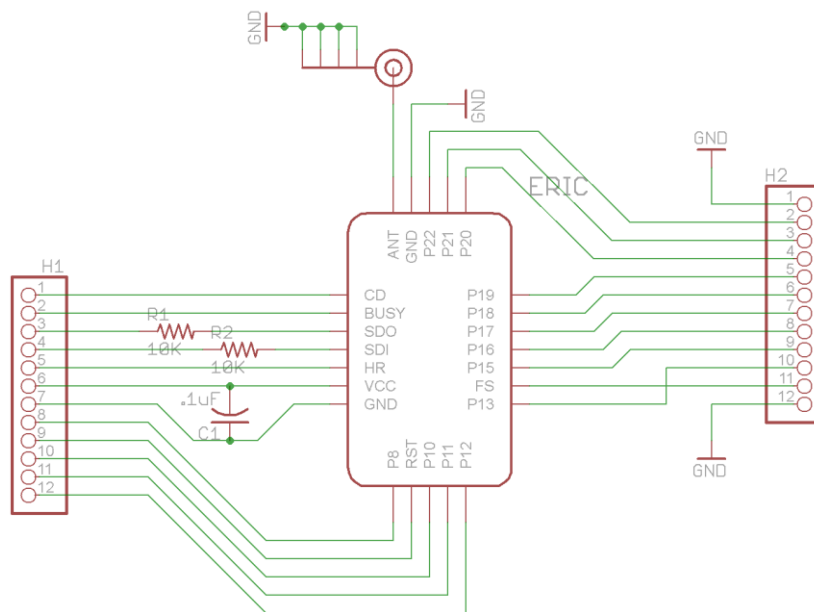

Note the 10k series resistors fitted to the SDO & SDI pins. Other eRIC pins (configured as inputs) may need to be similarly protected if connected to external 5V logic level signals.

## Acknowledgements

The design is 'Open Hardware' designed and published by Rick Winscot. Details: [www.quilix.com](http://www.quilix.com)

## Product Order Codes

Name	Description	Frequency	Order Code
eRIC400 Breakout Board	UK/European Version (eRIC Can Marked '4')	433MHz	eRIC4-BOB
eRIC900 Breakout Board	Europe/US Version (eRIC Can Marked '9')	868/915MHz	eRIC9-BOB
Antenna	UK & Europe	433MHz	ANTSR433
Antenna	Europe & USA	868/915MHz	ANTST900

## Document History

Issue	Date	Notes/Comments
V1.0	May 2015	This version

## Terms and Conditions of Use

Low Power Radio Solutions Ltd has an on-going policy to improve the performance and reliability of their products; we therefore reserve the right to make changes without notice. The information contained in this data sheet is believed to be accurate however we do not assume any responsibility for errors or any liability arising from the application or use of any product or circuit described herein. This data sheet neither states nor implies warranty of any kind, including fitness for any particular application.

easyRadio modules are a component part of an end system product and should be treated as such. Testing to fitness is the sole responsibility of the manufacturer of the device into which easyRadio products are fitted, and is expected BEFORE deployment into the field.

Any liability from defect or malfunction is limited to the replacement of product ONLY, and does not include labour or other incurred corrective expenses.

Using or continuing to use these devices hereby binds the user to these terms.



Low Power Radio Solutions Ltd.  
Two Rivers Industrial Estate  
Station Lane, Witney  
Oxon, OX28 4BH  
England

Tel: +44 (0)1993 709418  
Fax: +44 (0)1993 708575  
Web: <http://www.lprs.co.uk>  
Email: [info@lprs.co.uk](mailto:info@lprs.co.uk)  
Technical: [technical@lprs.co.uk](mailto:technical@lprs.co.uk)

# Mouser Electronics

Authorized Distributor

Click to View Pricing, Inventory, Delivery & Lifecycle Information:

LPRS:

[eRIC4-BOB](#) [eRIC9-BOB](#)