

# ATC 700 B Series NPO Porcelain and Ceramic Multilayer Capacitors

- Case B Size (.110" x .110")
- Low ESR/ESL
- Low Noise
- Rugged Construction
- Extended WVDC up to 1500 VDC
- Capacitance Range 0.1 pF to 5100 pF
- Zero TCC
- High Self-Resonance
- Established Reliability (QPL)

ATC, the industry leader, is announcing new improved ESR/ESL performance for the 700 B Series RF/Microwave Capacitors. The superior high self-resonance and zero TCC characteristic of this Series provide excellent performance over a broad range of RF and microwave applications requiring minimum drift, including RF power. Porcelain and ceramic construction provide a rugged, hermetic package.

Typical functional applications: Bypass, Coupling, Tuning and DC Blocking.

Typical circuit applications: Filters, Oscillators, Timing and RF Power Amplifiers.

## ENVIRONMENTAL TESTS

ATC 700 B Series Capacitors are designed and manufactured to meet and exceed the requirements of EIA-198, MIL-PRF-55681 and MIL-PRF-123.

### THERMAL SHOCK:

MIL-STD-202, Method 107, Condition A.

### MOISTURE RESISTANCE:

MIL-STD-202, Method 106.

### LOW VOLTAGE HUMIDITY:

MIL-STD-202, Method 103, Condition A, with 1.5 Volts DC applied while subjected to an environment of 85°C with 85% relative humidity for 240 hours min.

### LIFE TEST:

MIL-STD-202, Method 108, for 2000 hours, at 125°C.  
200% WVDC applied.

Voltage Applied:

200% of WVDC for capacitors rated at 500 volts DC or less.  
120% of WVDC for capacitors rated at 1250 volts DC or less.  
100% of WVDC for capacitors rated above 1250 volts DC

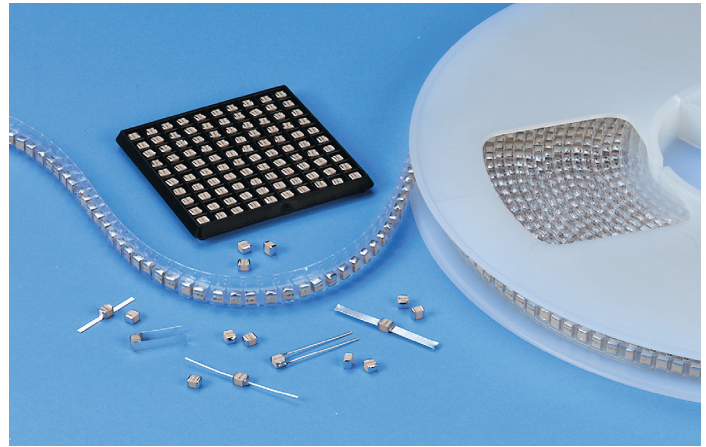

## ELECTRICAL AND MECHANICAL SPECIFICATIONS

### QUALITY FACTOR (Q):

Greater than 10,000 (0.1 pF to 200 pF) @ 1 MHz.

Greater than 2000 (220 pF to 1000 pF) @ 1 MHz.

Greater than 2000 (1100 pF to 5100 pF) @ 1 KHz.

### TEMPERATURE COEFFICIENT OF CAPACITANCE (TCC):

0 ±30 PPM/°C (-55°C to +125°C)

### INSULATION RESISTANCE (IR):

0.1 pF to 470 pF:

10<sup>6</sup> Megohms min. @ +25°C at rated WVDC.

10<sup>5</sup> Megohms min. @ +125°C at rated WVDC.

510 pF to 5100 pF:

10<sup>5</sup> Megohms min. @ +25°C at rated WVDC.

10<sup>4</sup> Megohms min. @ +125°C at rated WVDC.

**WORKING VOLTAGE (WVDC):** See Capacitance Values Table, page 2.

### DIELECTRIC WITHSTANDING VOLTAGE (DWV):

250% of WVDC for capacitors rated at 500 volts DC or less for 5 seconds.

150% of WVDC for capacitors rated at 1250 volts DC or less for 5 seconds.

120% of WVDC for capacitors rated above 1250 Volts DC for 5 seconds.

**RETRACE:** Less than ±(0.02% or 0.02 pF), whichever is greater.

**AGING EFFECTS:** None

**PIEZOELECTRIC EFFECTS:** None

(No capacitance variation with voltage or pressure).

**CAPACITANCE DRIFT:** ±(0.02% or 0.02 pF), whichever is greater.

### OPERATING TEMPERATURE RANGE:

0.1 to 200 pF: from -55°C to +175°C

220 to 5100 pF: from -55°C to +125°C

### TERMINATION STYLES:

Available in various surface mount and leaded styles.

See Mechanical Configurations, page 3.

**TERMINAL STRENGTH:** Terminations for chips and pellets withstand a pull of 5 lbs. min., 15 lbs. typical, for 5 seconds in direction perpendicular to the termination surface of the capacitor. Test per MIL-STD-202, method 211.



**AMERICAN**

ATC North America

sales@atceramics.com

**TECHNICAL**

ATC Europe

saleseur@atceramics.com

**CERAMICS**

ATC Asia

sales@atceramics-asia.com



ISO 9001 REGISTERED  
COMPANY

**THE ENGINEERS' CHOICE®**

**www.atceramics.com**

ATC # 001-814 Rev. V, 8/20

# ATC 700 B Capacitance Values

CAP. CODE	CAP. (pF)	TOL.	RATED WVDC		CAP. CODE	CAP. (pF)	TOL.	RATED WVDC		CAP. CODE	CAP. (pF)	TOL.	RATED WVDC		CAP. CODE	CAP. (pF)	TOL.	RATED WVDC	
			STD.	EXT.				STD.	EXT.				STD.	EXT.				STD.	EXT.
0R1	0.1	B	500	1500	3R3	3.3	B, C, D	500	1500	330	33	F, G, J, K, M	1000	331	330	F, G, J, K, M	N/A	200	
0R2	0.2				3R6	3.6				360	36			361	360				
0R3	0.3	3R9			3.9	390				39	391			390					
0R4	0.4	4R3			4.3	430				43	431			430					
0R5	0.5	4R7			4.7	470				47	471			470					
0R6	0.6	5R1			5.1	510				51	511			510					
0R7	0.7	5R6			5.6	560				56	561			560					
0R8	0.8	6R2			6.2	620				62	621			620					
0R9	0.9	6R8			6.8	680				68	681			680					
1R0	1.0	7R5			7.5	750				75	751			750					
1R1	1.1	8R2	8.2	820	82	821	820												
1R2	1.2	9R1	9.1	910	91	911	910												
1R3	1.3	B, C, D	500	1500	100	10	F, G, J, K, M	500	1500	101	100	F, G, J, K, M	1000	102	1000	F, G, J, K, M	N/A	50	
1R4	1.4				110	11				111	110			112	1100				
1R5	1.5				120	12				121	120			122	1200				
1R6	1.6				130	13				131	130			152	1500				
1R7	1.7				150	15				151	150			182	1800				
1R8	1.8				160	16				161	160			222	2200				
1R9	1.9				180	18				181	180			272	2700				
2R0	2.0				200	20				201	200			302	3000				
2R1	2.1				220	22				221	220			332	3300				
2R2	2.2				240	24				241	240			392	3900				
2R4	2.4	270	27	271	270	472	4700												
2R7	2.7	300	30	301	300	512	5100												
3R0	3.0																		

$VRMS = 0.707 \times WVDC$

- SPECIAL VALUES, TOLERANCES, HIGHER WVDC AND MATCHING AVAILABLE. • ENCAPSULATION OPTION AVAILABLE. PLEASE CONSULT FACTORY.
- Capacitance values in **bold** type indicate porcelain dielectric. All other capacitance values indicate ceramic dielectric.
- All 700 B Capacitors are available laser marked with ATC's identification, capacitance code and tolerance.
- NOTE: EXTENDED WVDC DOES NOT APPLY TO CDR PRODUCTS.

## ATC PART NUMBER CODE

Series 700 Case Size B Capacitance Code: 33 R=Decimal Point 1 Indicates number of zeros following digits of capacitance in picofarads except for decimal values. Capacitance Tolerance J

W Termination Code 500 WVDC X Laser Marking T Packaging

Packaging  
 T - Tape and Reel, 1000 pc. qty.\*  
 TV - Vertical Orientation of Product, Tape and Reel, 1000 pc. qty.\*  
 I - Special Packaging. Consult Factory.  
 \*Consult ATC for other quantities  
 ATC Cap-Pac® packaging (100 pc. qty. std.) is also available. For this option, leave last field blank.

CAPACITANCE TOLERANCE								
Code	B	C	D	F	G	J	K	M
Tol.	±0.1 pF	±0.25 pF	±0.5 pF	±1%	±2%	±5%	±10%	±20%

The above part number refers to a 700 B Series (case size B) 330 pF capacitor, J tolerance (±5%), 500 WVDC, with W termination (Tin/Lead, Solder Plated over Nickel Barrier), laser marking and Tape and Reel packaging.

For additional information and catalogs contact your ATC representative or call direct at (631) 622-4700.

Consult factory for additional performance data.

## AMERICAN TECHNICAL CERAMICS

ATC North America  
sales@atceramics.com

ATC Europe  
sales@atceramics.com

ATC Asia  
sales@atceramics-asia.com

# ATC 700 B Capacitors: Mechanical Configurations

ATC SERIES & CASE SIZE	ATC TERM. CODE	MIL-PRF-55681	CASE SIZE & TYPE	OUTLINES W/T IS A TERMINATION SURFACE	BODY DIMENSIONS INCHES (mm)			LEAD AND TERMINATION DIMENSIONS AND MATERIALS			
					LENGTH (L)	WIDTH (W)	THICKNESS (T)	OVERLAP (Y)	MATERIALS		
700B	W	CDR14BG	B Solder Plate		.110+.025 -.010 (2.79 +0.64 -.025)	.110 ±.015 (2.79 ±0.38)	.102 (2.59) max.	.102 (2.59) max..	Tin/Lead, Solder Plated over Nickel Barrier Termination		
700B	P	CDR14BG	B Pellet		.110 +.035 -.010 (2.79 +0.89 -.025)	.110 ±.015 (2.79 ±0.38)	.102 (2.59)		Heavy Tin/Lead Coated, over Nickel Barrier Termination		
700B	T	N/A	B Solderable Nickel Barrier		.110 +.025 -.010 (2.79 +0.64 -.025)	.110 ±.015 (2.79 ±0.38)	.102 (2.59)		<b>RoHS Compliant</b> Tin Plated over Nickel Barrier Termination		
700B	CA	CDR13BG	B Gold Chip		.110 +.025 -.010 (2.79 +0.64 -.025)	.110 ±.015 (2.79 ±0.38)	.102 (2.59)		<b>RoHS Compliant</b> Gold Plated over Nickel Barrier Termination		
700B	MS	CDR21BG	B Microstrip		.135 ±.015 (3.43 ±0.38)	.110 ±.015 (2.79 ±0.38)	.120 (3.05) max.	N/A	Length (L <sub>L</sub> )	Width (W <sub>L</sub> )	Thickness (T <sub>L</sub> )
700B	AR	CDR22BG	B Axial Ribbon						.250 (6.35) min.	.093 ±.005 (2.36 ± 0.13)	.004 ± .001 (.102 ± .025)
700B	RR	CDR24BG	B Radial Ribbon		.145 ±.020 (3.68 ±0.51)	.110 ±.015 (2.79 ±0.38)	.102 (2.59) max.	N/A	.500 (12.7)	#26 AWG., .016 (.406) dia. nominal	
700B	RW	CDR23BG	B Radial Wire								
700B	AW	CDR25BG	B Axial Wire						.950 min.		

Additional lead styles available: Narrow Microstrip (NM), Narrow Axial Ribbon (NA) and Vertical Narrow Microstrip (H). Other lead lengths are available; consult factory. All leads are high purity silver attached with high temperature solder and are **RoHS** compliant. For a complete military catalog, request American Technical Ceramics document ATC 001-818.

# ATC 700 B Capacitors: Non-Magnetic Mechanical Configurations\*

ATC SERIES & CASE SIZE	ATC TERM. CODE	MIL-PRF-55681	CASE SIZE & TYPE	OUTLINES W/T IS A TERMINATION SURFACE	BODY DIMENSIONS INCHES (mm)			LEAD AND TERMINATION DIMENSIONS AND MATERIALS			
					LENGTH (L)	WIDTH (W)	THICKNESS (T)	OVERLAP (Y)	MATERIALS		
700B	WN	Meets Requirements	B Non-Mag Solder Plate		.110 +.020 -.010 (2.79 +0.51 -0.25)	.110 ±.015 (2.79 ±0.38)	.102 (2.59) max..	.102 (2.59) ±.010 (0.25)	Tin/Lead, Solder Plated over Non-Magnetic Barrier Termination		
700B	PN	Meets Requirements	B Non-Mag Pellet		.110 +.035 -.010 (2.79 +0.89 -0.25)	.110 ±.015 (2.79 ±0.38)			Heavy Tin/Lead, Coated over Non-Magnetic Barrier Termination		
700B	TN	Meets Requirements	B Non-Mag Solderable Barrier		.110 +.020 -.010 (2.79 +0.51 -0.25)	.110 ±.015 (2.79 ±0.38)			<b>RoHS Compliant</b> Tin Plated over Non-Magnetic Barrier Termination		
700B	MN	Meets Requirements	B Non-Mag Microstrip		.135 ±.015 (3.43 ±0.38)	.110 ±.015 (2.79 ±0.38)	.120 (3.05) max.	N/A	Length (L <sub>L</sub> )	Width (W <sub>L</sub> )	Thickness (T <sub>L</sub> )
700B	AN	Meets Requirements	B Non-Mag Axial Ribbon						.250 (6.35) (6.35) min.	.093 ± .005 (2.36 ± 0.13)	.004 ± .001 (.102 ± .025)
700B	FN	Meets Requirements	B Non-Mag Radial Ribbon						.145 ±.020 (3.68 ±0.51)	.102 (2.59) max.	N/A
700B	RN	Meets Requirements	B Non-Mag Radial Wire								
700B	BN	Meets Requirements	B Non-Mag Axial Wire								

\*Capacitors with values greater than 200 pF contain a trace magnetic element that may exhibit weak magnetic properties.

\*\*Additional lead styles available: Narrow Microstrip (DN), Narrow Axial Ribbon (GN) and Vertical Narrow Microstrip (HN). Other lead lengths are available; consult factory; All leads are high purity silver attached with high temperature solder and are RoHS compliant.

## Suggested Mounting Pad Dimensions

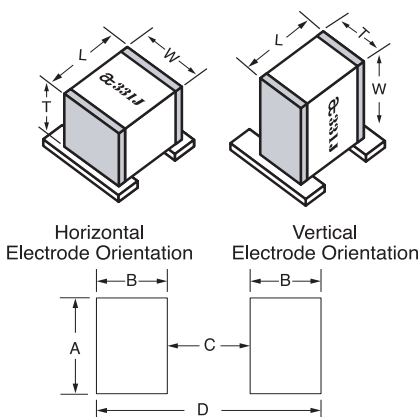

Case B Vertical Mount

Cap Value		A Min.	B Min.	C Min.	D Min.
0.1 pF	Normal	.065	.050	.075	.175
	High Density	.045	.030	.075	.135
0.2 pF	Normal	.090	.050	.075	.175
	High Density	.070	.030	.075	.135
0.3 to 510 pF	Normal	.110	.050	.075	.175
	High Density	.090	.030	.075	.135
> 510 pF	Normal	.120	.050	.075	.175
	High Density	.100	.030	.075	.135

Horizontal Mount

All values		A Min.	B Min.	C Min.	D Min.
All values	Normal	.130	.050	.075	.175
	High Density	.110	.030	.075	.135

A M E R I C A N T E C H N I C A L C E R A M I C S

ATC North America  
sales@atceramics.com

ATC Europe  
sales@atceramics.com

ATC Asia  
sales@atceramics-asia.com

# ATC 700 B Performance Data

**ESR VS. CAPACITANCE  
ATC SERIES 700, CASE B**

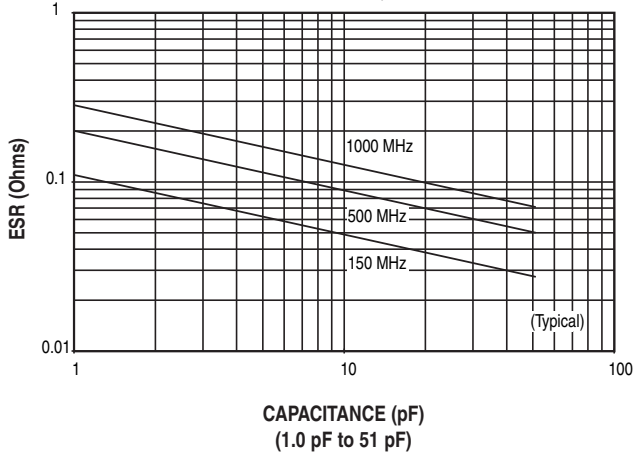

**Q VS. CAPACITANCE  
ATC SERIES 700, CASE B**

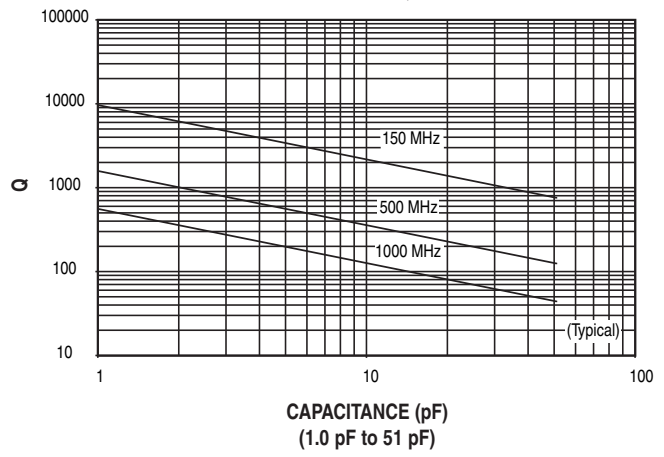

**ESR VS. CAPACITANCE  
ATC SERIES 700, CASE B**

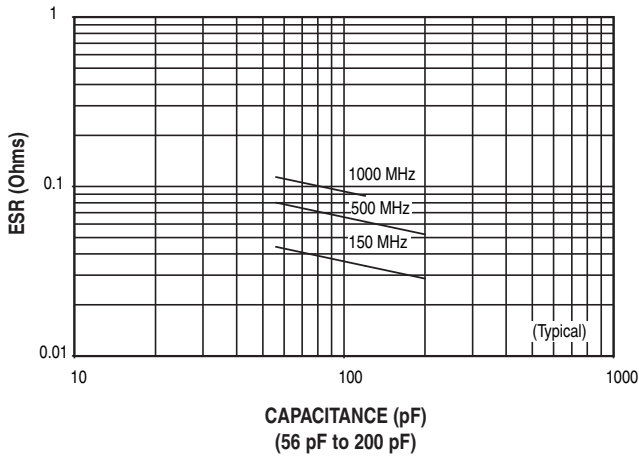

**Q VS. CAPACITANCE  
ATC SERIES 700, CASE B**

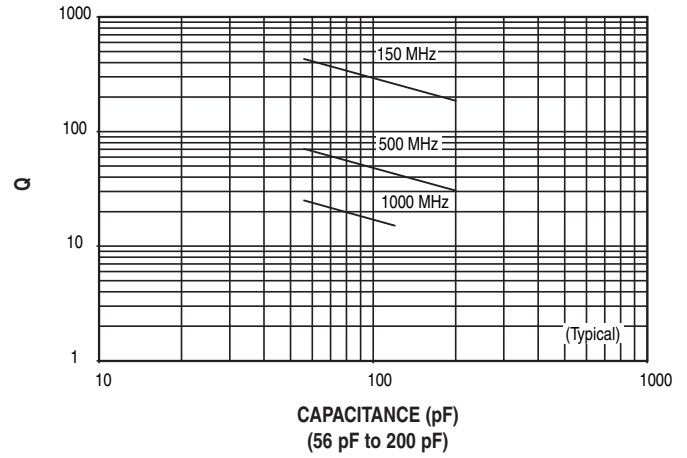

**ESR VS. CAPACITANCE  
ATC SERIES 700, CASE B**

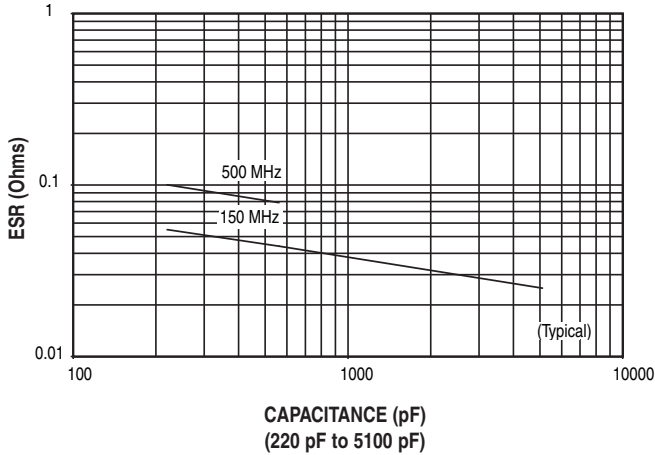

**Q VS. CAPACITANCE  
ATC SERIES 700, CASE B**

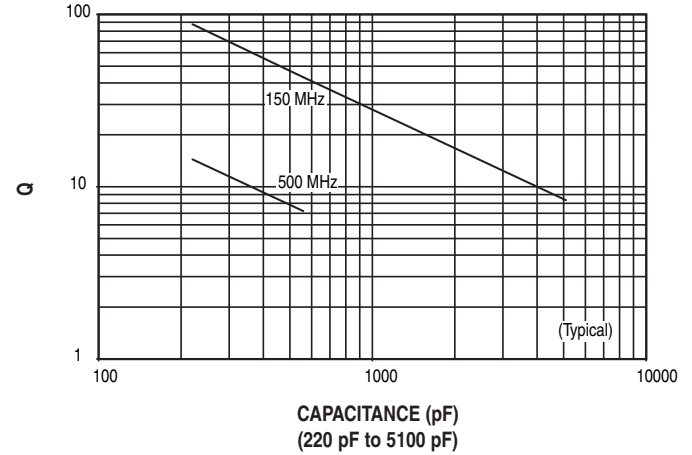

**A M E R I C A N   T E C H N I C A L   C E R A M I C S**

ATC North America  
sales@atceramics.com

ATC Europe  
saleseur@atceramics.com

ATC Asia  
sales@atceramics-asia.com

www.atceramics.com

# ATC 700 B Performance Data

**SERIES RESONANCE VS. CAPACITANCE  
ATC SERIES 700, CASE B**

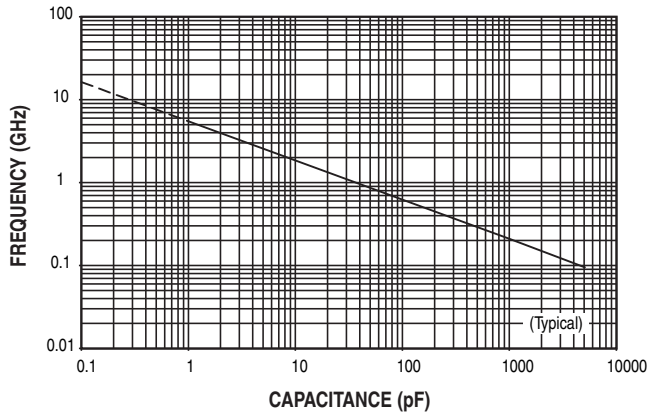

**CURRENT RATING VS. CAPACITANCE  
ATC SERIES 700, CASE B**

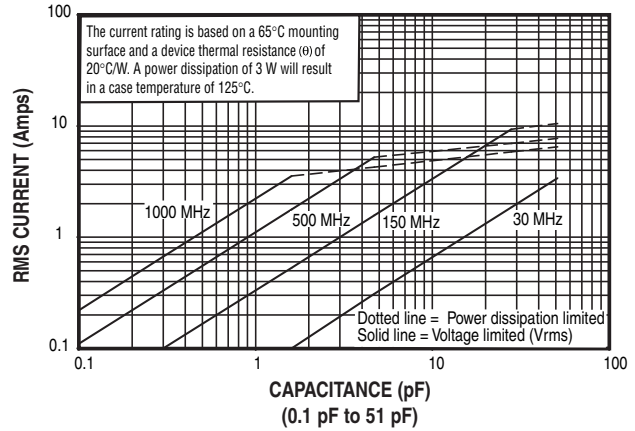

**CURRENT RATING VS. CAPACITANCE  
ATC SERIES 700, CASE B**

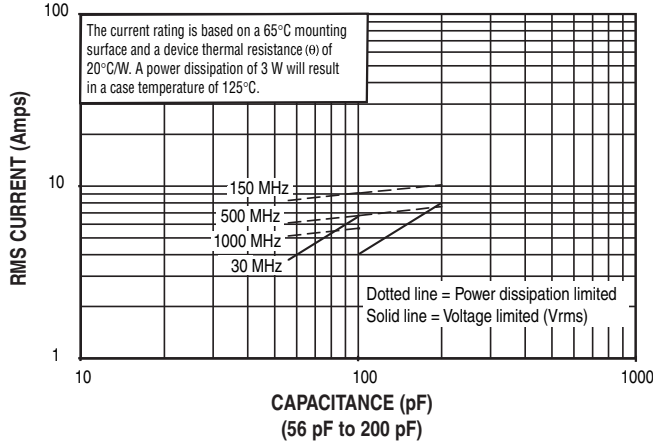

**CURRENT RATING VS. CAPACITANCE  
ATC SERIES 700, CASE B**

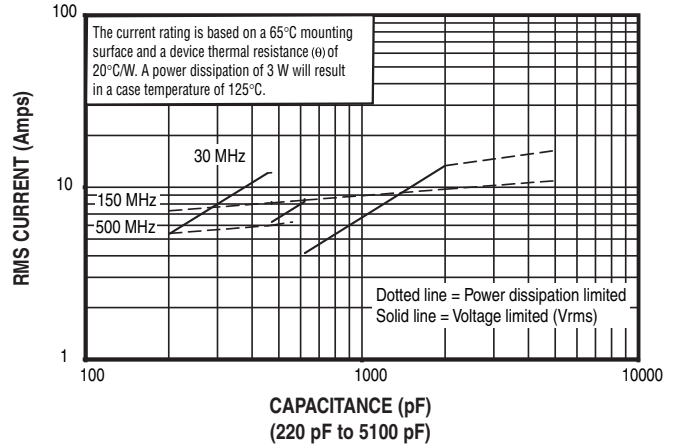

**CAPACITANCE CHANGE VS. TEMPERATURE  
ATC SERIES 700, CASE B**

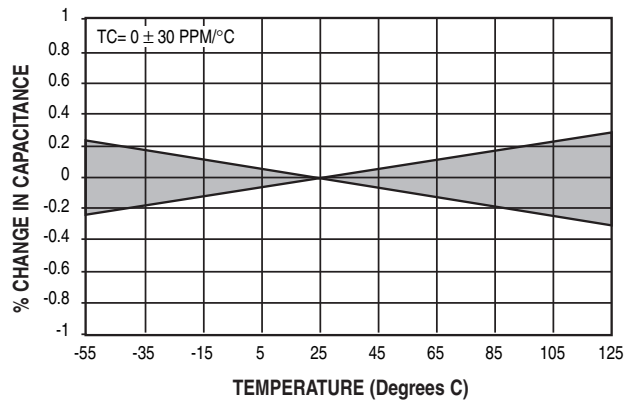

# ATC 700 B Performance Data

**CURRENT RATING VS. CAPACITANCE**  
**ATC SERIES 700, CASE B, EXTENDED VOLTAGE**

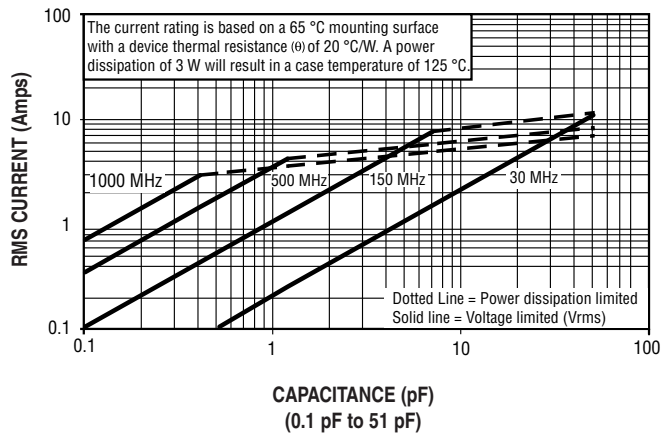

**CURRENT RATING VS. CAPACITANCE**  
**ATC SERIES 700, CASE B, EXTENDED VOLTAGE**

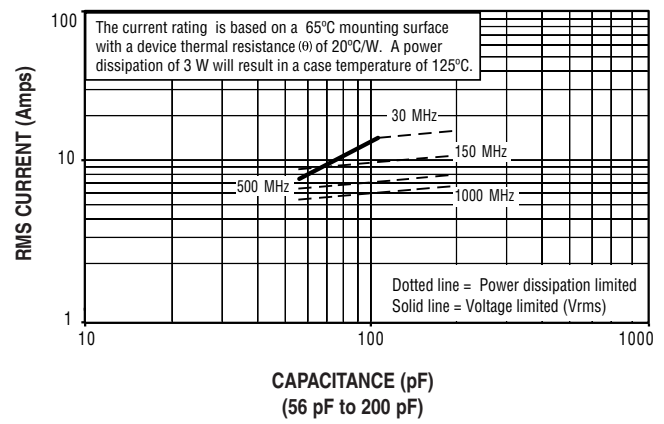

**A M E R I C A N   T E C H N I C A L   C E R A M I C S**

ATC North America  
 sales@atceramics.com

ATC Europe  
 saleseur@atceramics.com

ATC Asia  
 sales@atceramics-asia.com

www.atceramics.com

*Sales of ATC products are subject to the terms and conditions contained in American Technical Ceramics Corp. Terms and Conditions of Sale (ATC document #001-992). Copies of these terms and conditions will be provided upon request. They may also be viewed on ATC's website at [www.atceramics.com/productfinder/default.asp](http://www.atceramics.com/productfinder/default.asp). Click on the link for Terms and Conditions of Sale.*

*ATC has made every effort to have this information as accurate as possible. However, no responsibility is assumed by ATC for its use, nor for any infringements of rights of third parties which may result from its use. ATC reserves the right to revise the content or modify its product without prior notice.*

© 1996 American Technical Ceramics Corp. All Rights Reserved

ATC # 001-814 Rev. V, 8/20

**A M E R I C A N   T E C H N I C A L   C E R A M I C S**

**ATC North America**

[sales@atceramics.com](mailto:sales@atceramics.com)

**ATC Europe**

[saleseur@atceramics.com](mailto:saleseur@atceramics.com)

**ATC Asia**

[sales@atceramics-asia.com](mailto:sales@atceramics-asia.com)

---

**w w w . a t c e r a m i c s . c o m**