

50 Watts

- Ultra Wide 12:1 Input Range (14-160 VDC)
- Single Output
- Industry Standard 1/4 Brick
- -40 °C to +100 °C Operation
- 3000 VDC Isolation
- Output Trim -20/+10%
- Remote On/Off and Remote Sense
- Complies with EN50155
- Meets EN50121-3-2
- 3 Year Warranty



Dimensions:

RDF50:

1.45 x 2.28 x 0.5" (36.8 x 57.9 x 12.7 mm)

Models & Ratings

Input Voltage	Output Voltage	Output Current	Input Current ⁽¹⁾		Ripple & noise ⁽²⁾	Efficiency ⁽³⁾	Max. capacitive load	Model Number ^(4,5)
			No Load	Full Load				
14-160 VDC	5 V	6.00 A	5 mA	2.90 A	100 mV	83.0%	4700 µF	RDF5072WS05
	12 V	4.20 A	5 mA	4.30 A	150 mV	87.0%	3300 µF	RDF5072WS12
	24 V	2.10 A	5 mA	4.20 A	240 mV	89.0%	1200 µF	RDF5072WS24
	48 V	1.05 A	5 mA	4.25 A	480 mV	88.0%	680 µF	RDF5072WS48

Notes

1. Typical at 14 VDC input.
2. Measured at 20 MHz bandwidth and 10 µF electrolytic capacitor.
3. Measured at 72 VDC input.

4. For negative logic option, add suffix -N.
5. For threaded baseplate option, add suffix -T.

Mechanical Details

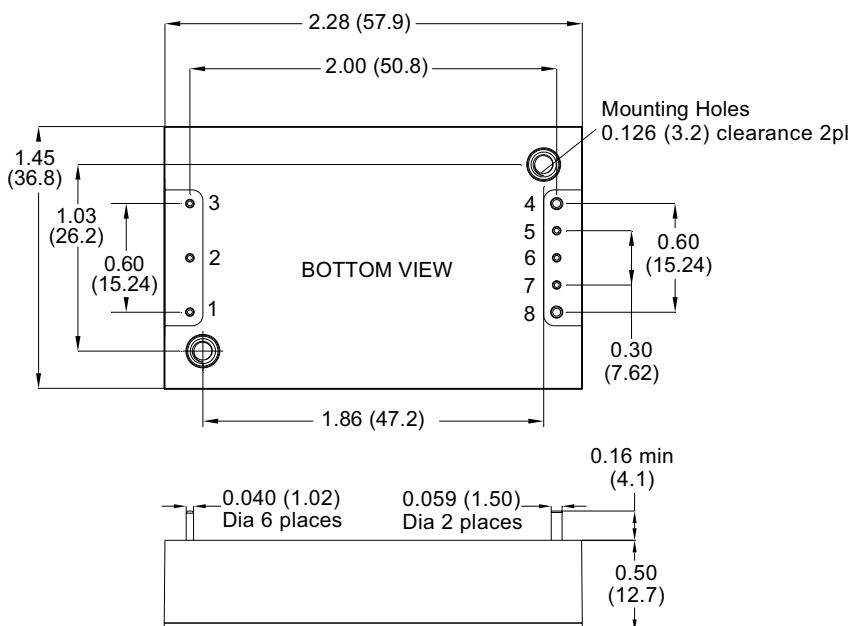

Pin Connections	
Pin	Single
1	+Vin
2	Remote On/Off
3	-Vin
4	-Vout
5	-Sense
6	Trim
7	+Sense
8	+Vout

Notes

1. All dimensions are in inches (mm)
2. Weight: 0.24 lbs (109 g) approx.
3. Tolerance: x.x = ±0.5 (x.xx = ±0.25)
x.xxx = ±0.02 (x.xxxx = ±0.01)
4. Option -T for baseplate with screw threads

Input

Characteristic	Minimum	Typical	Maximum	Units	Notes & Conditions
Input Voltage Range	14		160	VDC	Covers 24, 48, 72 & 110 VDC nominal inputs
Input Surge			200	VDC	For 100 ms
Undervoltage Lockout		14.6		VDC	On
		12.0			Off
Lockout Hysteresis		1.5		VDC	
Idle Current		3	5	mA	When output is inhibited
Inrush Current			0.1	A ² s	
Recommended Input Fuse		8		A	Time delay type
Input Reflected Ripple Current		40		mA pk-pk	Through 10 µH inductor

Output

Characteristic	Minimum	Typical	Maximum	Units	Notes & Conditions
Output Voltage	5		48	VDC	See Models and Ratings table
Output Trim	-20		+10	%	See Application Note
Initial Set Accuracy			±1.0	%	At full load
Minimum Load	0			%	No minimum load required
Line Regulation			±0.5	%	From minimum to maximum input at full load
Load Regulation			±0.2	%	From 0% to full load for single/dual output
Transient Response			±5.0	%	Maximum deviation, recovering to less than 1% in 250 µs for 25% step load change.
Start Up Time		15		ms	
Output Voltage Rise Time		10		ms	
Ripple & Noise				mV pk-pk	See models and ratings table
Overload Protection	110	180	200	%	
Short Circuit Protection					Continuous hiccup mode, with auto recovery
Maximum Capacitive Load					See Models and Ratings table
Temperature Coefficient			0.02	%/°C	
Overvoltage Protection	115	125	140	%	
Remote On/Off	Output is on if remote on/off (pin 2) is open or high (3.5-160 VDC) Output turns off if remote on/off (pin 2) is low (option -N for Negative logic)				

General

Characteristic	Minimum	Typical	Maximum	Units	Notes & Conditions
Efficiency		88		%	See Models and Ratings table
Isolation: Input to Output Input to Case Output to Case	3000			VDC	60 s
	2500				
	500			VAC	
Switching Frequency	180	200	220	kHz	Fixed
Isolation Resistance	10 ⁹			Ω	
Isolation Capacitance		1000		pF	Input to Output
		1500			Input to Case
		10000			Output to Case
Power Density			30	W/in ³	
Mean Time Between Failure		780		kHrs	MIL-HDBK-217F, +25 °C GB
Weight		0.136 (61.5)		lb (g)	

Environmental

Characteristic	Minimum	Typical	Maximum	Units	Notes & Conditions
Operating Base Plate Temperature	-40		+100	°C	
Storage Temperature	-55		+125	°C	
Thermal Protection		107		°C	
Humidity			95	%RH	Non-condensing
Cooling					Base plate cooled

Safety Approvals

Agency	Standard	Notes & Conditions
UL	cUL60950-1	ITE

EMC: Emissions

Phenomenon	Standard	Test Level	Notes & Conditions
ITE	EN55032	Class A	See Application Notes
Railway Equipment	EN50121-3-2		See Application Notes

EMC: Immunity

Phenomenon	Standard	Test Level	Criteria	Notes & Conditions
Railway Equipment	EN50121-3-2			See Application Notes
ESD Immunity	EN61000-4-2	±6 kV/±8 kV	A	Contact Discharge/Air Discharge
Radiated Immunity	EN61000-4-3	20 V rms	A	
EFT/Burst	EN61000-4-4	±2 kV	A	With external electrolytic capacitor 68 µF/400 V across input pins
Surge	EN61000-4-5	±2 kV	A	With external electrolytic capacitor 68 µF/400 V across input pins
Conducted Immunity	EN61000-4-6	10 V rms	A	
Magnetic Fields	EN61000-4-8	3 A/m	A	

Mechanical Details

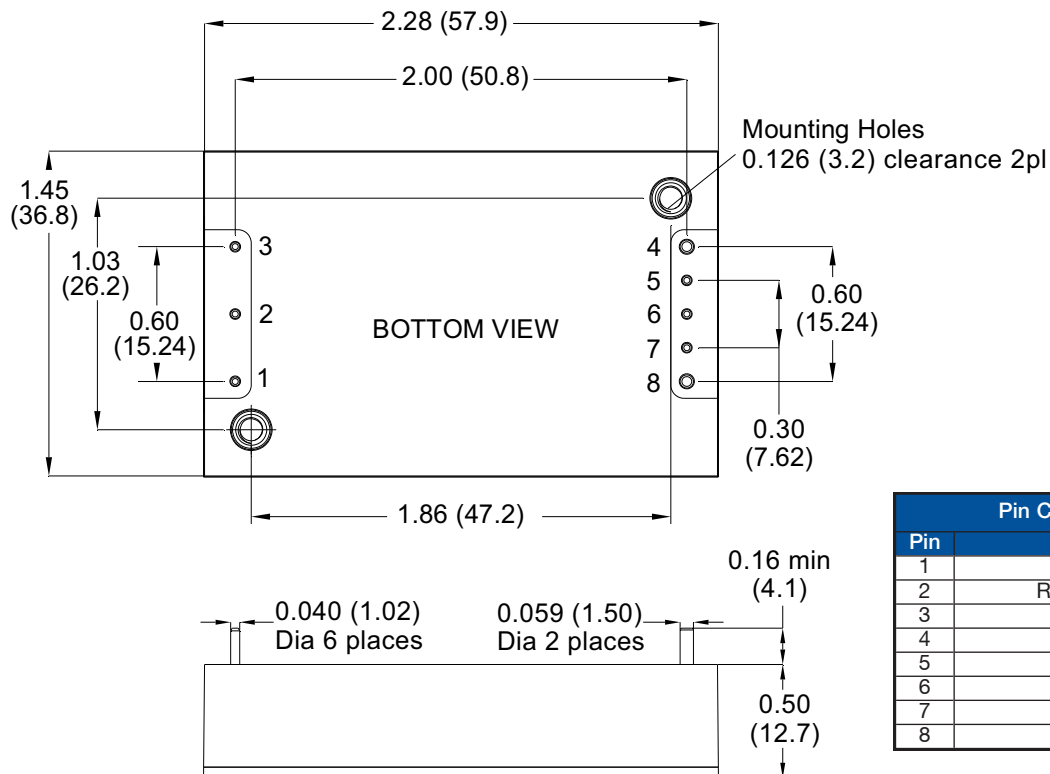

Pin Connections	
Pin	Single
1	+Vin
2	Remote On/Off
3	-Vin
4	-Vout
5	-Sense
6	Trim
7	+Sense
8	+Vout

Notes

- All dimensions are in inches (mm)
- Weight: 0.24 lbs (109 g) approx.

- Tolerance: x.x = ±0.5 (x.xx = ±0.25), x.xx = ±0.02 (x.xxx = ±0.01)
- Option -T for baseplate with screw threads

Application Notes

Input Fusing and Safety Considerations

The RDF50 series converters have no internal fuse. In order to achieve maximum safety and system protection, always use an input line fuse. We recommended a 30 A fast acting fuse. It is recommended that the circuit has a transient voltage suppressor diode (TVS) across the input terminals to protect the unit against surge or spike voltages and input reverse voltage (as shown). A suitable part would be 1.5KE180A.

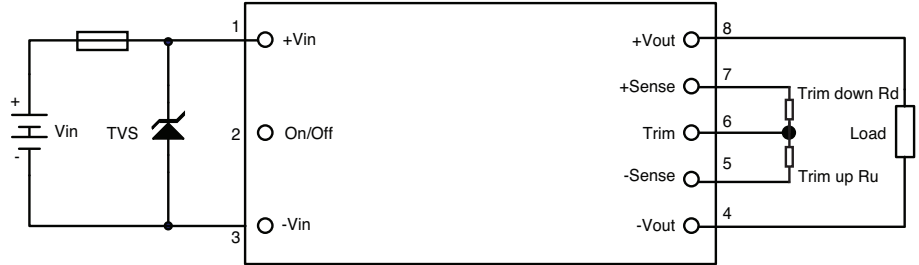

Output Voltage Adjustment

The Trim input permits the user to adjust the output voltage up by 10% or down by 20%. This is accomplished by connecting an external resistor between the Trim pin and either the +Sense pin or the -Sense pin.

To Trim Down

Connecting an external resistor (R_d) between the Trim pin and the Vout (+) (or +Sense) pin decreases the output voltage. The following table can be used to determine the required external resistor value to obtain a percentage output voltage change of $\Delta\%$.

Trim Down %	5 V	12 V	24 V	48 V
	Rtrim_down (k Ω)			
1	215.8	687.3	1703	3294
2	103.0	327.1	807.8	1588
3	65.40	207.0	509.2	1019
4	46.60	147.0	359.9	735.1
5	35.32	110.9	270.3	564.5
6	27.80	86.96	210.6	450.7
7	22.43	69.81	167.9	369.5
8	18.40	56.95	135.9	308.5
9	15.27	46.94	111.0	261.1
10	12.76	38.94	91.16	223.2
11	10.71	32.39	74.87	192.2
12	9.00	26.93	61.20	166.3
13	7.55	22.31	49.82	144.5
14	6.31	18.35	39.97	125.7
15	5.24	14.92	31.44	109.5
16	4.30	11.92	23.97	95.28
17	3.47	9.277	17.29	82.73
18	2.73	6.923	11.53	71.58
19	2.07	4.817	6.298	61.60
20	1.48	2.921	1.583	52.62

To Trim Up

Connecting an external resistor (R_u) between the Trim pin and the Vout (-) (or -Sense) pin increases the output voltage. The following table can be used to determine the required external resistor value to obtain a percentage output voltage change of $\Delta\%$.

Trim Up %	5 V	12 V	24 V	48 V
	Rtrim_up (k Ω)			
1	50.45	154.1	164.0	147.3
2	24.34	74.95	78.64	71.29
3	15.63	48.56	50.18	45.93
4	11.28	35.37	35.94	33.24
5	8.67	27.45	27.40	25.63
6	6.93	22.17	21.71	20.56
7	5.69	18.41	17.64	16.94
8	4.75	15.58	14.59	14.22
9	4.03	13.38	12.22	12.10
10	3.45	11.62	10.32	10.41

Thermal Resistance Information

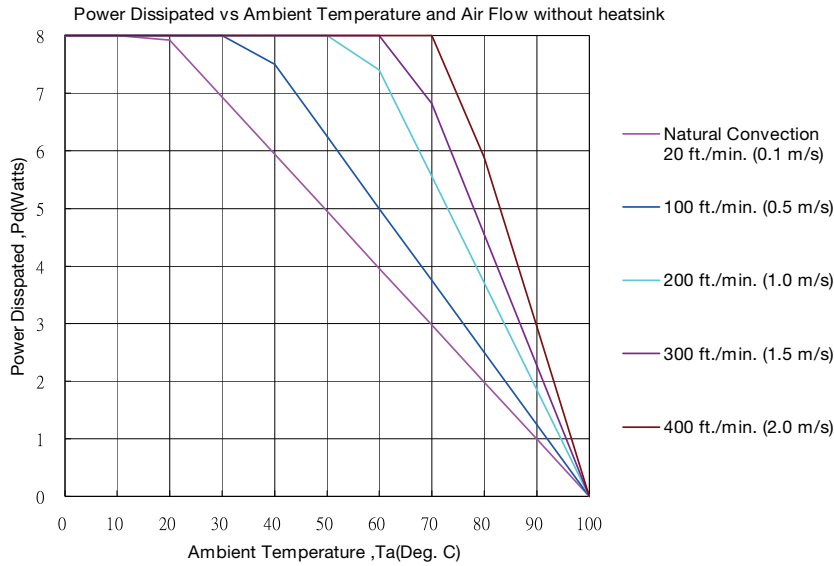

Air Flow Rate	Typical Rca
Natural Convection 20 ft/min (0.1 m/s)	10.1 °C/W
100 ft/min (0.5 m/s)	8.0 °C/W
200 ft/min (1.0 m/s)	5.4 °C/W
300 ft/min (1.5 m/s)	4.4 °C/W
400 ft/min (2.0 m/s)	3.4 °C/W

Airflow Derating Graph

Example (Without Heatsink)

To determine the minimum airflow necessary for a RDF5072S12 operating at an input voltage of 72 V, an output current of 4.20 A, and a maximum ambient temperature of 40°C:

Determine Power dissipation (Pd): $Pd = Pi - Po = Po(1-\eta)$,

$$Pd = 12 V \times 4.2 A \times (1 - 0.87) / 0.87 = 7.53 \text{ Watts}$$

Where Pi = Input power, Po = Output Power and η = Efficiency

Determine airflow from airflow derating graph using data points for $Pd = 7.53 W$ and $Ta = 40^\circ C$

Minimum airflow = 200 ft./min.

To check that the maximum case temp of 100 °C is not exceeded:

Maximum temperature rise is $\Delta T = Pd \times Rca = 7.53 \times 5.4 = 40.67^\circ C$.

Maximum case temperature is

$$Tc = Ta + \Delta T = 80.67^\circ C < 100^\circ C$$

Where: Rca is the thermal resistance from case to ambient environment. Ta is ambient temperature and Tc is case temperature.

EMC Filter - EN55032 Emissions and Immunity

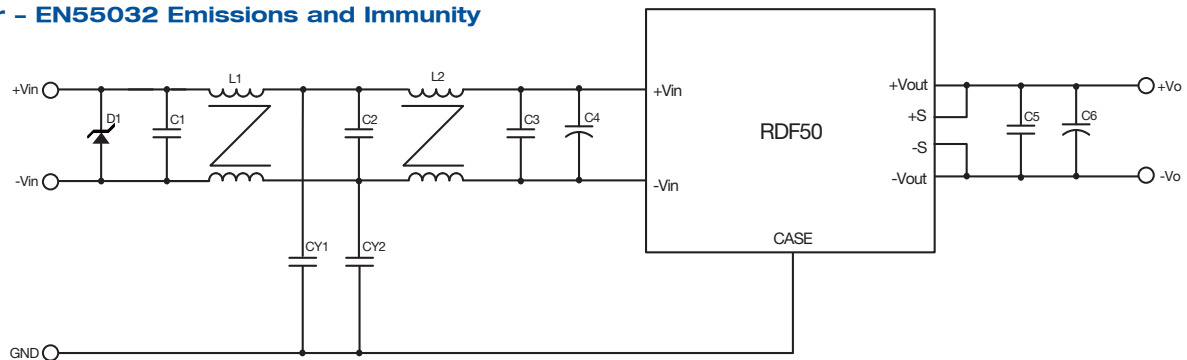

C1, C3, C3	C4	C5	C6	CY1, CY2	D1	L1, L2
1 μF /250 V 1812 Ceramic Cap.	82 μF /250 V KXJ Series Aluminium Cap.	1 μF /100 V 1206 Ceramic Cap.	22 μF /100 V Solid Aluminium Cap.	1500 pF	1.5 KE 180 A	URT24-50055H 5.5 mH

Note: C4 UNITED CHEMI-CON KXJ series or equivalent, CY1, CY2 MURATA Y1 capacitors or equivalent, L1, L2 BULL WILL URT24-05055H or equivalent.

Mouser Electronics

Authorized Distributor

Click to View Pricing, Inventory, Delivery & Lifecycle Information:

[XP Power:](#)

[RDF5072WS48](#) [RDF5072WS12](#) [RDF5072WS24](#) [RDF5072WS05](#)