

REVISIONS				
P.	LTN.	DESCRIPTION	DATE	APVD.
A		RELEASED PER ECO-19-014475	01OCT2019	CJV JW

PICK AND PLACE TAPE SHOWN AS TRANSPARENT FOR CLARITY

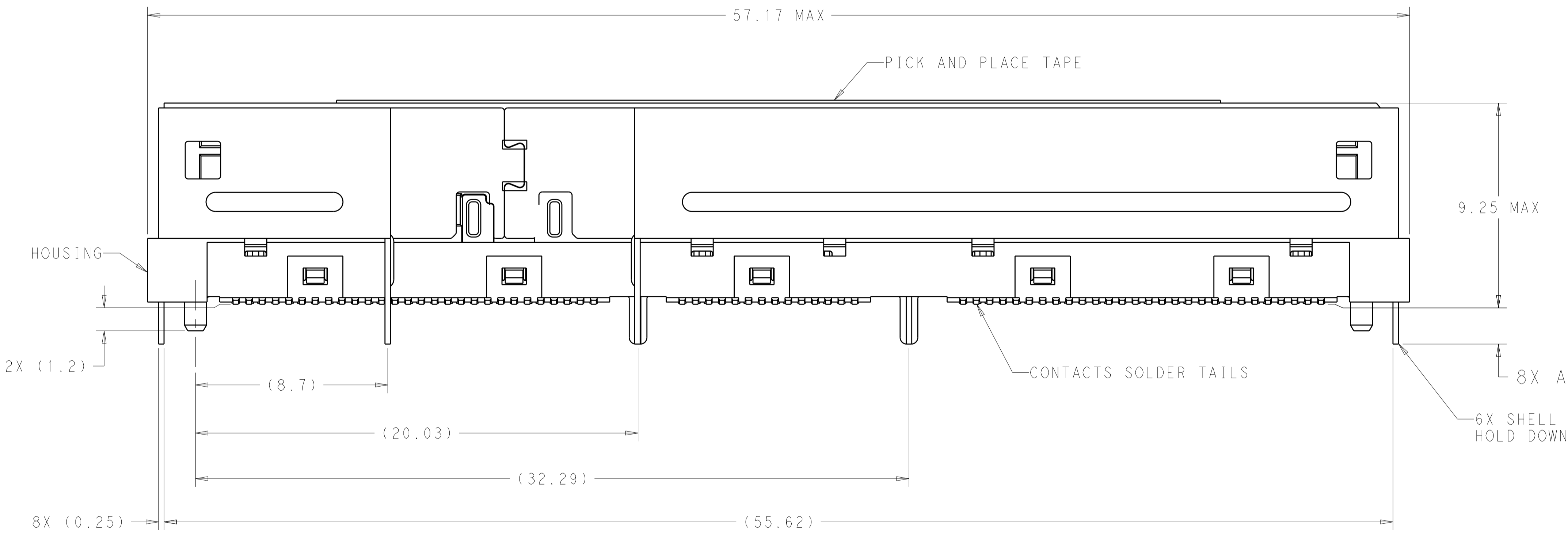

1. HOUSING AND CONTACT OVERMOLDS - LCP, UL94V-0, BLACK. SHELL, CONTACTS AND HOLD DOWNS - COPPER ALLOY. PICK AND PLACE TAPE - POLYIMIDE FILM.
2. CONTACTS - GOLD PLATE ON MATING SURFACES, TIN PLATE ON SOLDER FEET. HOLD DOWNS - TIN PLATE. SHELL - TIN PLATE.
3. DATUMS AND BASIC DIMENSIONS ESTABLISHED BY CUSTOMER.
4. MINIMUM HOST PCB THICKNESS: 1.5.
5. SEE MSA SPECIFICATION FOR ADDITIONAL PADDLE CARD LAYOUTS COMPATIBLE WITH THIS RECEPTACLE AND FOR OPTIONAL SPLIT CONTACT PAD LAYOUTS FOR THE PADDLE CARD. SPECIFICATION PINOUT MAY ALSO DESIGNATE PAD SEQUENCE DIFFERENT FROM ILLUSTRATION.
6. POSITIONS DESIGNATED AS "SIGNAL" ARE REQUIRED LOCATIONS FOR HIGH SPEED DIFFERENTIAL PAIR SIGNALING. THESE LOCATIONS MAY ALSO BE USED FOR SUPPORTING SIDEBAND SIGNALS OR OTHER UTILITY PURPOSES. POSITIONS DESIGNATED AS "GROUND" ARE REQUIRED WHEN SUPPORTING HIGH SPEED DIFFERENTIAL SIGNALS. THESE LOCATIONS MAY ALSO BE USED FOR SIDEBAND SIGNALS OR OTHER UTILITY PURPOSES.
7. RECOMMENDED COMPONENT AND TRACE KEEP OUT AREA. EACH EDGE 0.15 MIN FROM EDGE OF HOLE.
8. TAPE AND REEL PACKAGED FOR PICK AND PLACE SMT PROCESSING, SEE FIGURE 1. POCKET TAPE WIDTH = 72.

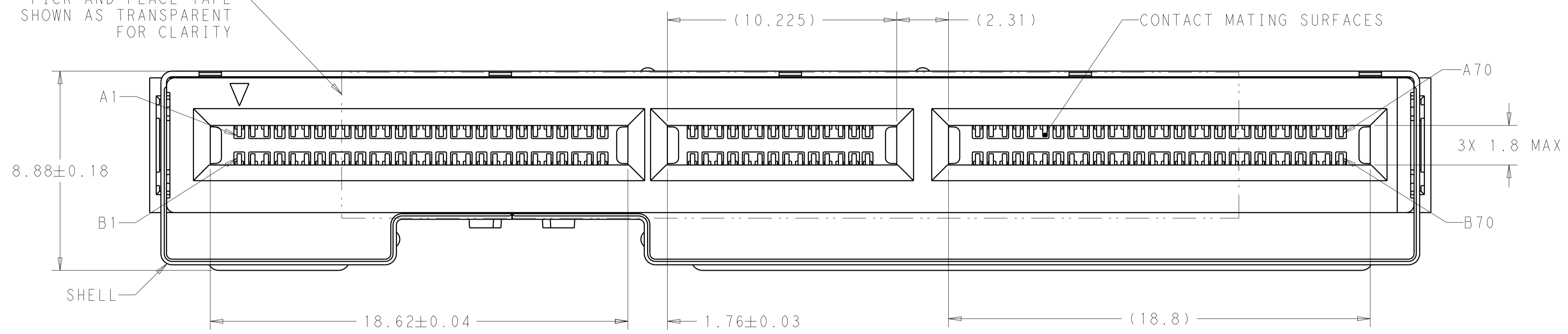
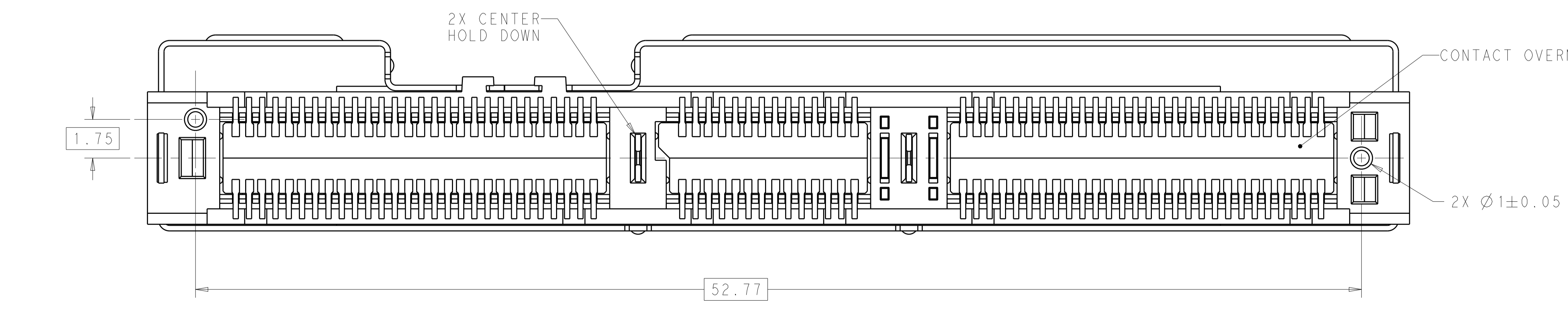
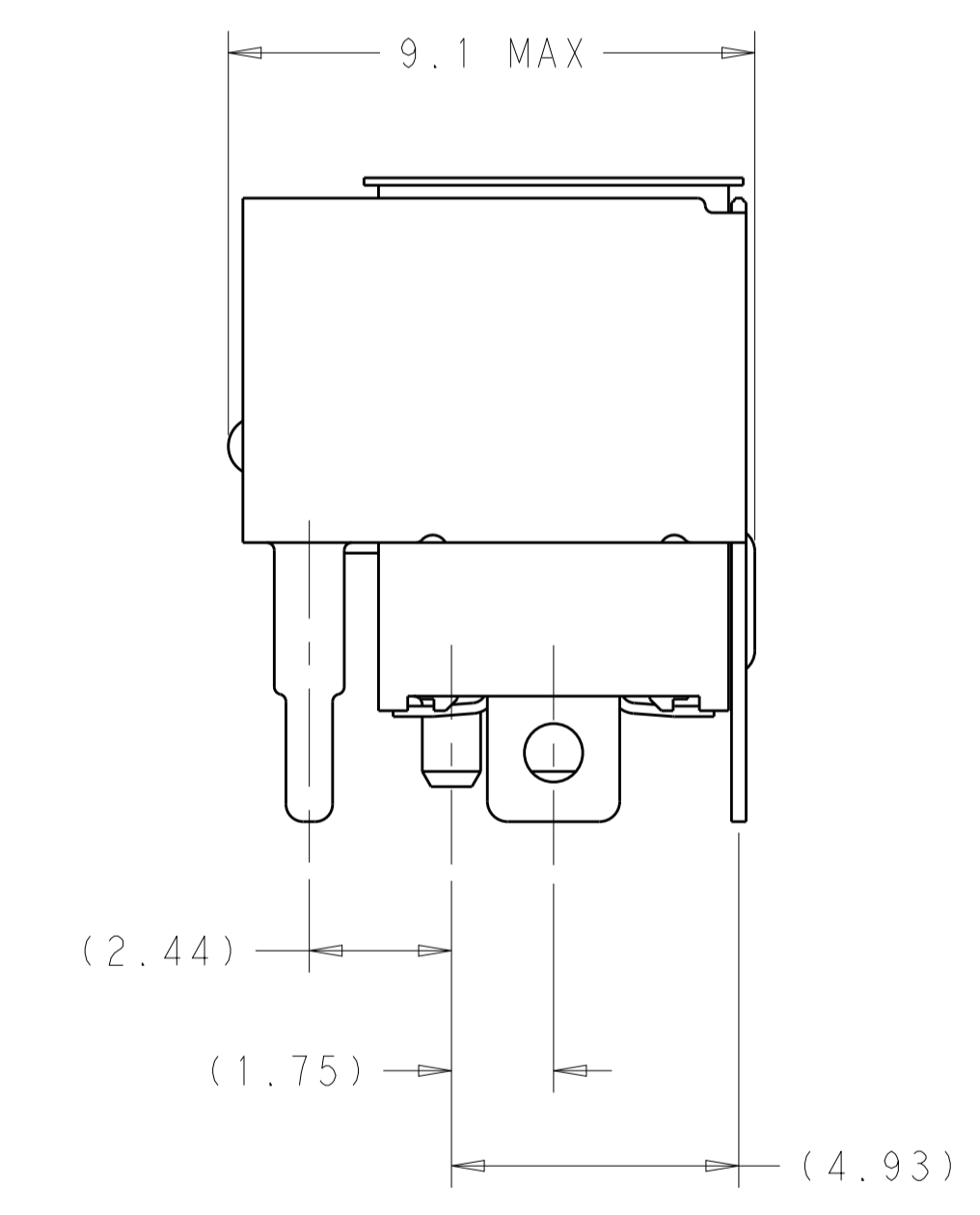

SEE SHEET 4 FOR PART TABLE

THIS DRAWING IS A CONTROLLED DOCUMENT.		OWN: B. MATTHEWS 26MAR2018	TE Connectivity
DIMENSIONS: mm		CHK: D. HARMON 26MAR2018	
TOLERANCES UNLESS OTHERWISE SPECIFIED:		APVD: D. HARMON 26MAR2018	NAME: RECEPTACLE ASSEMBLY, VERTICAL, 140 POSITION, SLIVER 2.0
0 PLC ±	1 PLC ±	PRODUCT SPEC 108-130021	SIZE: CAGE CODE DRAWING NO. RESTRICTED TO
2 PLC ±	3 PLC ±	APPLICATION SPEC 114-130015	A100779C=2332139
4 PLC ±	ANGLES ±	WEIGHT	CUSTOMER DRAWING SCALE 8:1 SHEET 1 OF 4 REV A
MATERIAL	FINISH		



REVISIONS				
P.	LTN.	DESCRIPTION	DATE	APVD.
-	-	SEE SHEET 1	-	-

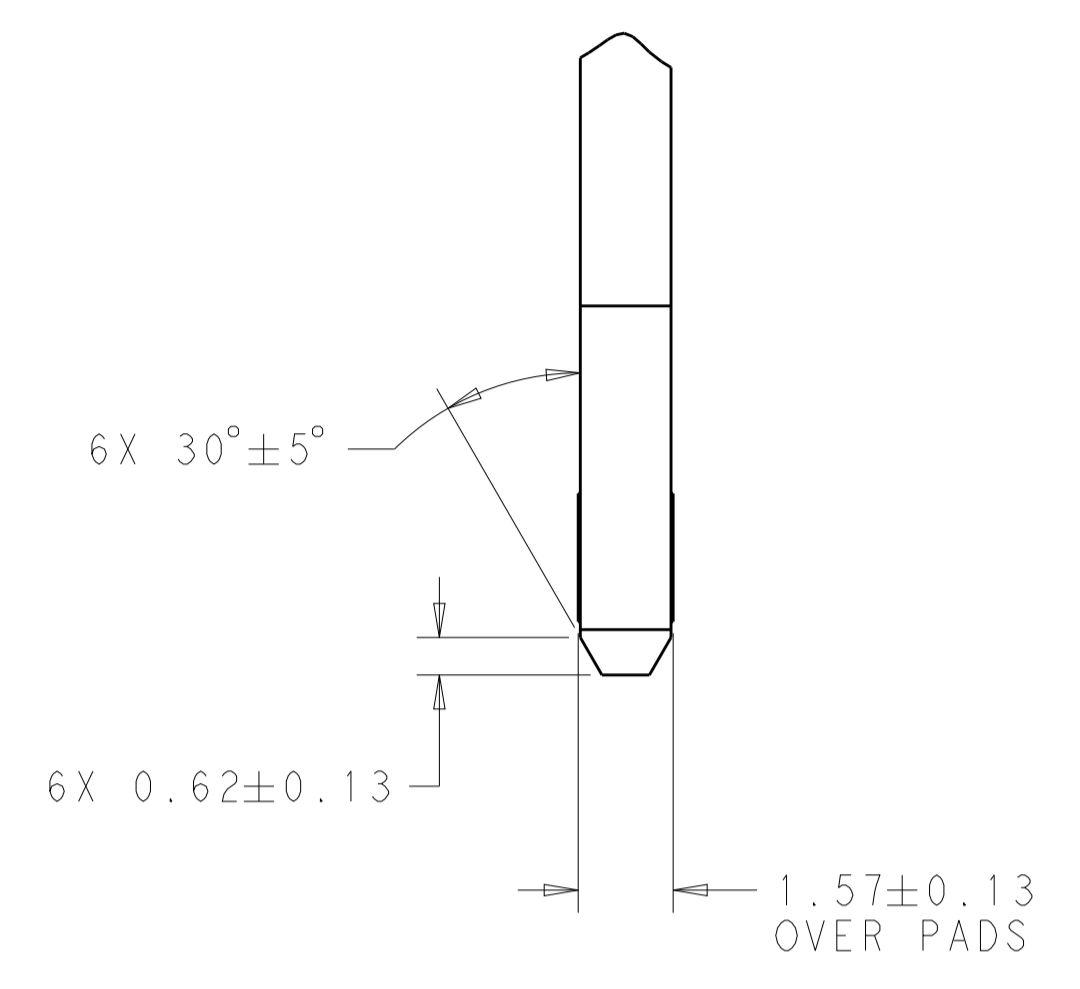
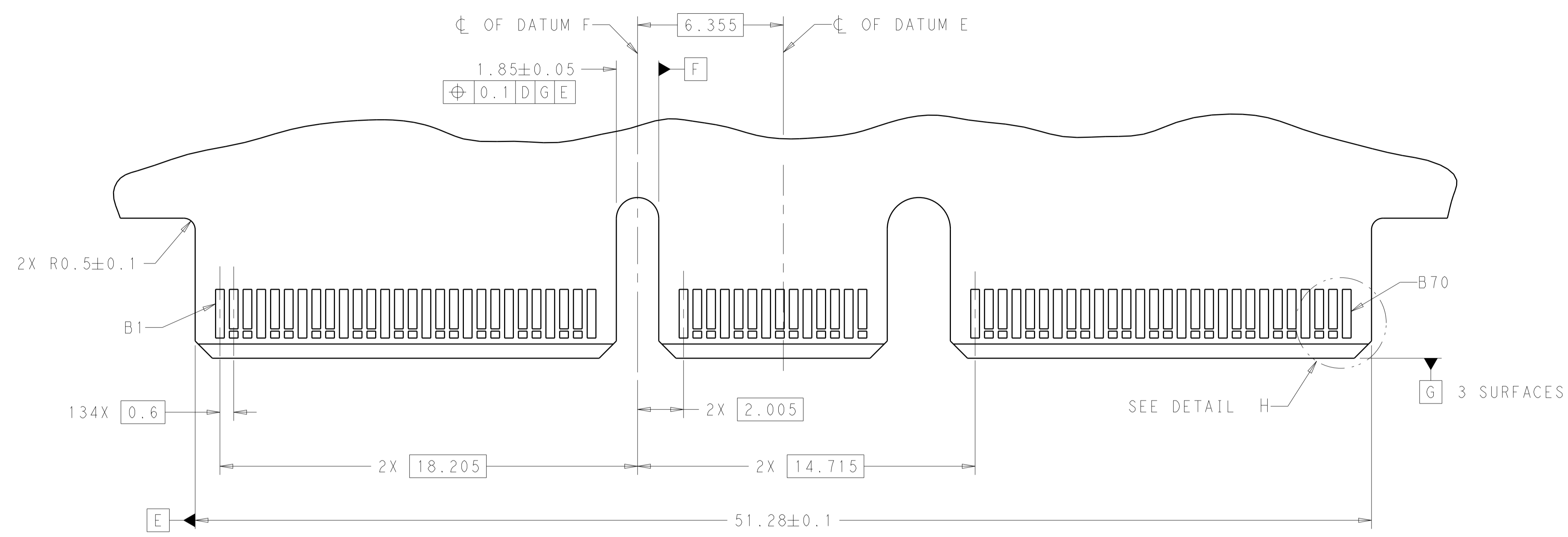

RECOMMENDED PCB OUTLINE DIMENSIONS.  
 TOLERANCE VALUES ARE CRITICAL. PLEASE BE SURE TO DESIGNATE  
 TOLERANCES TO PCB SUPPLIER TO ENSURE OPTIMIZED FUNCTIONALITY.

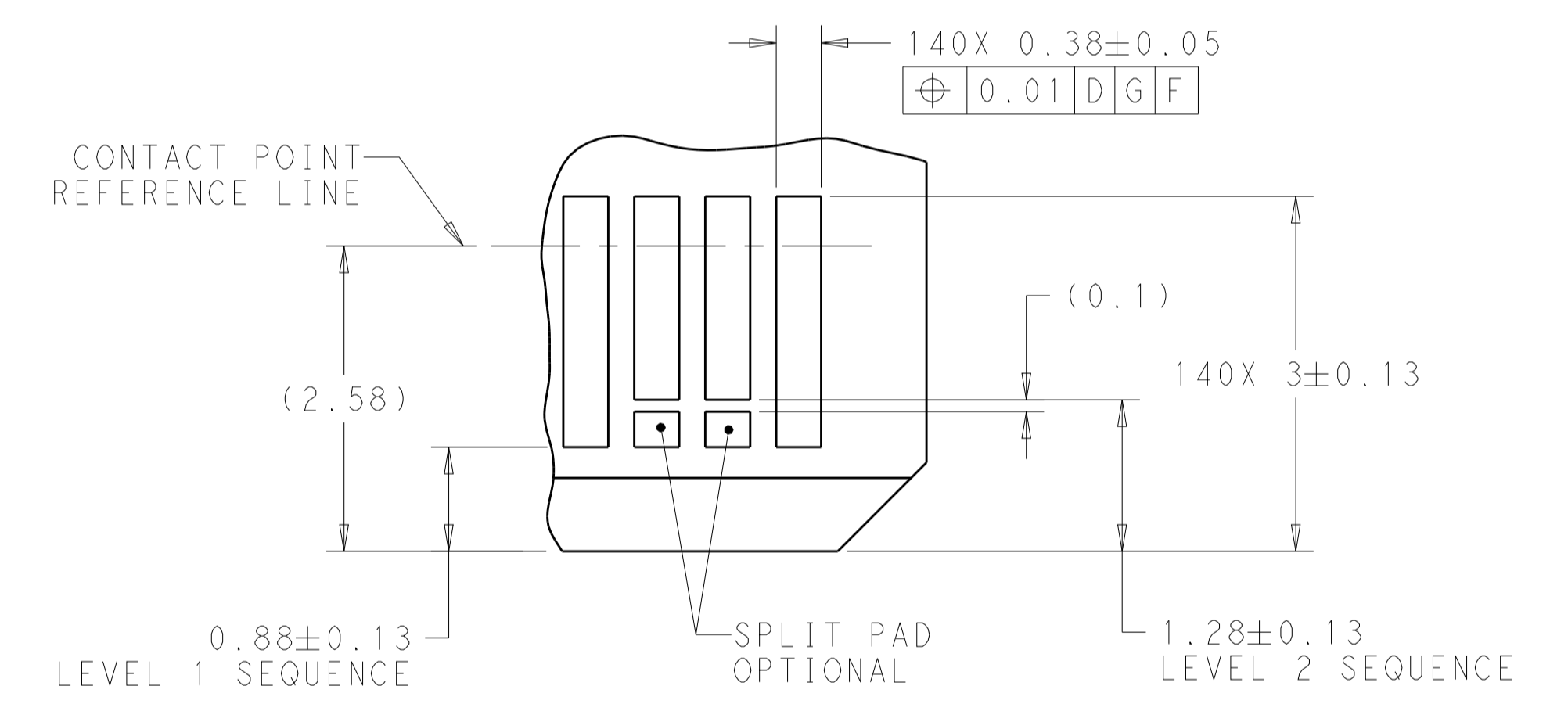
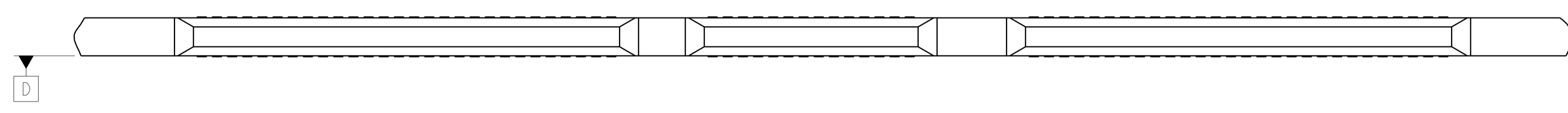

DETAIL H  $\Delta$   
 SCALE 20:1

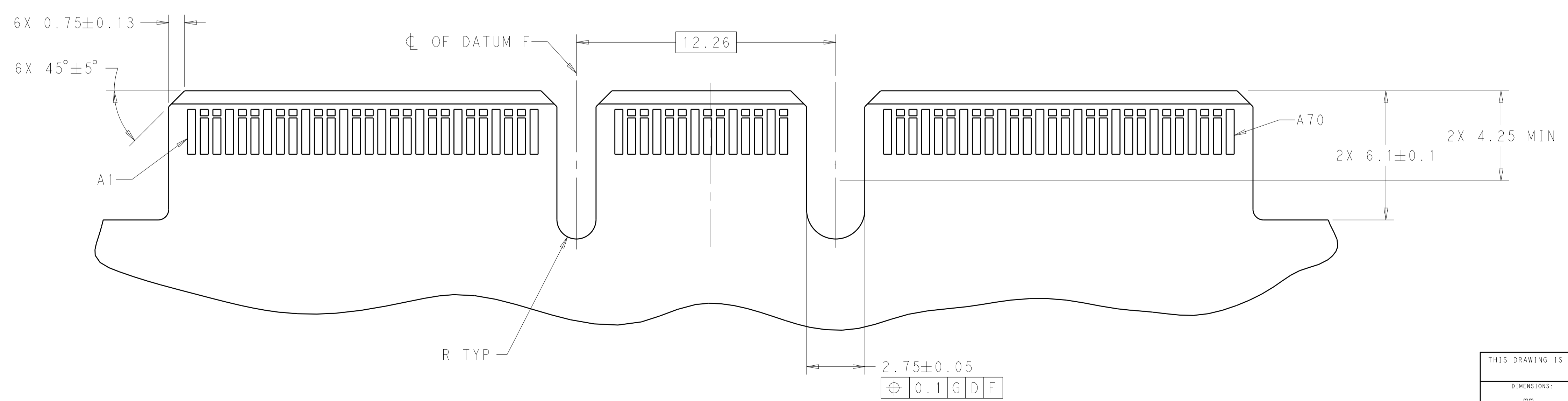

THIS DRAWING IS A CONTROLLED DOCUMENT.		DWN B. MATTHEWS 26MAR2018 CHK D. HARMON 26MAR2018 APVD D. HARMON 26MAR2018	TE Connectivity NAME RECEPTACLE ASSEMBLY, VERTICAL, 140 POSITION, SLIVER 2.0	
DIMENSIONS: mm 	TOLERANCES UNLESS OTHERWISE SPECIFIED: 0 PLC ± 1 PLC ± 2 PLC ± 3 PLC ± 4 PLC ± ANGLES ± FINISH ±	PRODUCT SPEC 108-130021 APPLICATION SPEC 114-130015 WEIGHT CUSTOMER DRAWING		SIZE CAGE CODE DRAWING NO A100779C=2332139 RESTRICTED TO
4805 (3/13)		SCALE 8:1	SHEET 3 OF 4	REV A

REVISIONS				
P.	LTN	DESCRIPTION	DATE	APVD
-	-	SEE SHEET 1	-	-

TABLE 1: CONNECTOR CONTACT IDENTIFICATION  

CONTACT NUMBER	SIDE A	SIDE B
1	GROUND	GROUND
2	SIGNAL	SIGNAL
3	SIGNAL	SIGNAL
4	GROUND	GROUND
5	SIGNAL	SIGNAL
6	SIGNAL	SIGNAL
7	GROUND	GROUND
8	SIGNAL	SIGNAL
9	SIGNAL	SIGNAL
10	GROUND	GROUND
11	SIGNAL	SIGNAL
12	SIGNAL	SIGNAL
13	GROUND	GROUND
14	SIGNAL	SIGNAL
15	SIGNAL	SIGNAL
16	GROUND	GROUND
17	SIGNAL	SIGNAL
18	SIGNAL	SIGNAL
19	GROUND	GROUND
20	SIGNAL	SIGNAL
21	SIGNAL	SIGNAL
22	GROUND	GROUND
23	SIGNAL	SIGNAL
24	SIGNAL	SIGNAL
25	GROUND	GROUND
26	SIGNAL	SIGNAL
27	SIGNAL	SIGNAL
28	GROUND	GROUND
29	GROUND	GROUND
30	SIGNAL	SIGNAL
31	SIGNAL	SIGNAL
32	GROUND	GROUND
33	SIGNAL	SIGNAL
34	SIGNAL	SIGNAL
35	GROUND	GROUND

CONTACT NUMBER	SIDE A	SIDE B
36	SIGNAL	SIGNAL
37	SIGNAL	SIGNAL
38	GROUND	GROUND
39	SIGNAL	SIGNAL
40	SIGNAL	SIGNAL
41	GROUND	GROUND
42	GROUND	GROUND
43	GROUND	GROUND
44	SIGNAL	SIGNAL
45	SIGNAL	SIGNAL
46	GROUND	GROUND
47	SIGNAL	SIGNAL
48	SIGNAL	SIGNAL
49	GROUND	GROUND
50	SIGNAL	SIGNAL
51	SIGNAL	SIGNAL
52	GROUND	GROUND
53	SIGNAL	SIGNAL
54	SIGNAL	SIGNAL
55	GROUND	GROUND
56	SIGNAL	SIGNAL
57	SIGNAL	SIGNAL
58	GROUND	GROUND
59	SIGNAL	SIGNAL
60	SIGNAL	SIGNAL
61	GROUND	GROUND
62	SIGNAL	SIGNAL
63	SIGNAL	SIGNAL
64	GROUND	GROUND
65	SIGNAL	SIGNAL
66	SIGNAL	SIGNAL
67	GROUND	GROUND
68	SIGNAL	SIGNAL
69	SIGNAL	SIGNAL
70	GROUND	GROUND

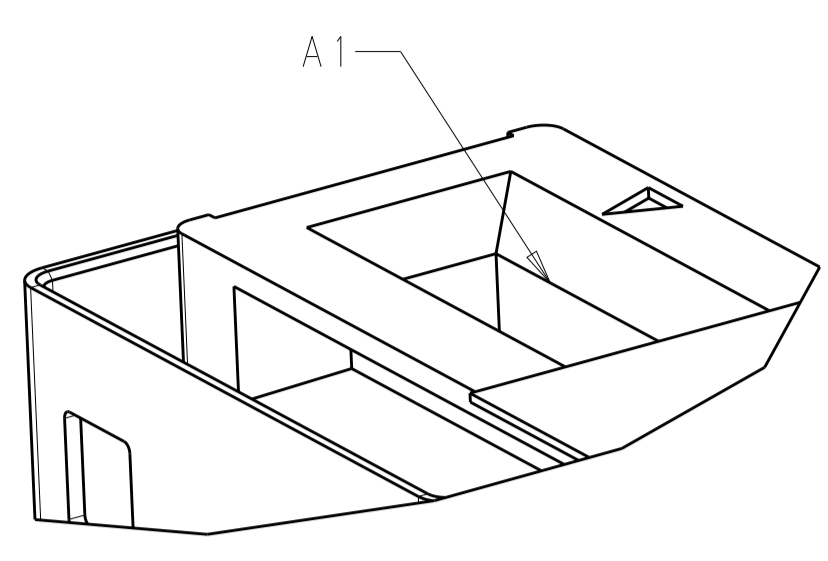

DETAIL C  
SCALE 10:1

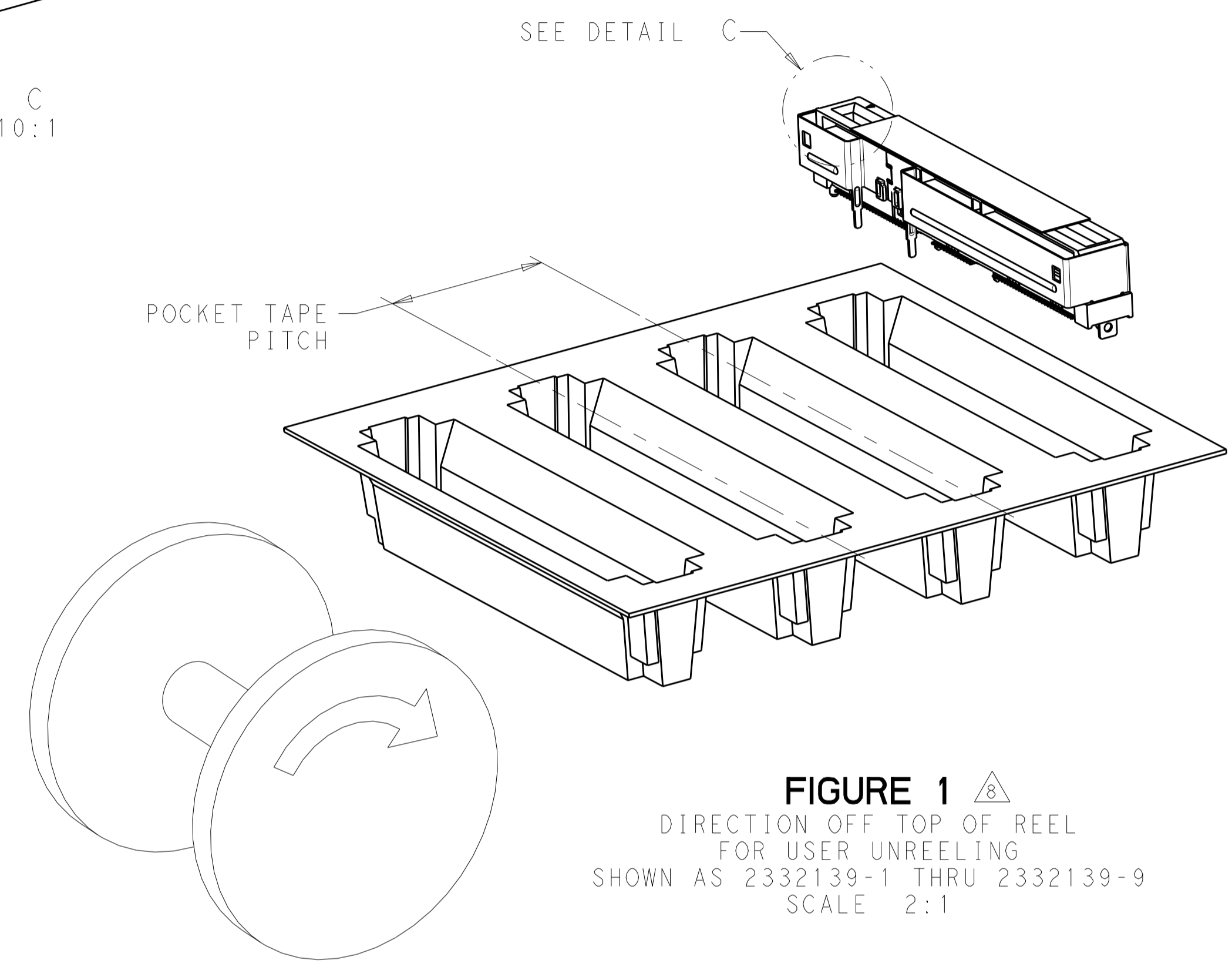

**FIGURE 1**   
DIRECTION OFF TOP OF REEL  
FOR USER UNREELING  
SHOWN AS 2332139-1 THRU 2332139-9  
SCALE 2:1

SIZE	CAGE CODE	DRAWING NO	RESTRICTED TO
1.2±0.1	NO	0.76µm Au 0.38µm Au FLASH Au/PdNi	24 250 NO 200 1-2332139-9 100 1-2332139-8 50 1-2332139-7
1.8±0.1	NO	0.76µm Au 0.38µm Au FLASH Au/PdNi	24 250 NO 200 1-2332139-6 100 1-2332139-5 50 1-2332139-4
1.8±0.1	YES	0.76µm Au 0.38µm Au FLASH Au/PdNi	24 250 NO 200 1-2332139-3 100 1-2332139-2 50 1-2332139-1
1.2±0.1	NO	0.76µm Au 0.38µm Au FLASH Au/PdNi	20 300 YES 200 2332139-9 100 2332139-8 50 2332139-7
1.8±0.1	NO	0.76µm Au 0.38µm Au FLASH Au/PdNi	20 300 YES 200 2332139-6 100 2332139-5 50 2332139-4
1.8±0.1	YES	0.76µm Au 0.38µm Au FLASH Au/PdNi	20 300 YES 200 2332139-3 100 2332139-2 50 2332139-1
A	CENTER HOLD DOWN	PLATING	POCKET TAPE PITCH REEL QUANTITY PICK AND PLACE TAPE MATING CYCLES PART NUMBER

THIS DRAWING IS A CONTROLLED DOCUMENT.

DIMENSIONS: mm

TOLERANCES UNLESS OTHERWISE SPECIFIED:

0 PLC	±
1 PLC	±
2 PLC	±
3 PLC	±
4 PLC	±
ANGLES	±
FINISH	±

MATERIAL

APVD: B. MATTHEWS, D. HARMON, D. HARMON

DATE: 26MAR2018

NAME: RECEPTACLE ASSEMBLY, VERTICAL, 140 POSITION, SLIVER 2.0

SIZE: A1

SCALE: 8:1

SHEET: 4 OF 4

REV: A

CUSTOMER DRAWING

# Mouser Electronics

Authorized Distributor

Click to View Pricing, Inventory, Delivery & Lifecycle Information:

[TE Connectivity:](#)

[2332139-2](#)