

7513D2-L Litepipe™ Description and Features

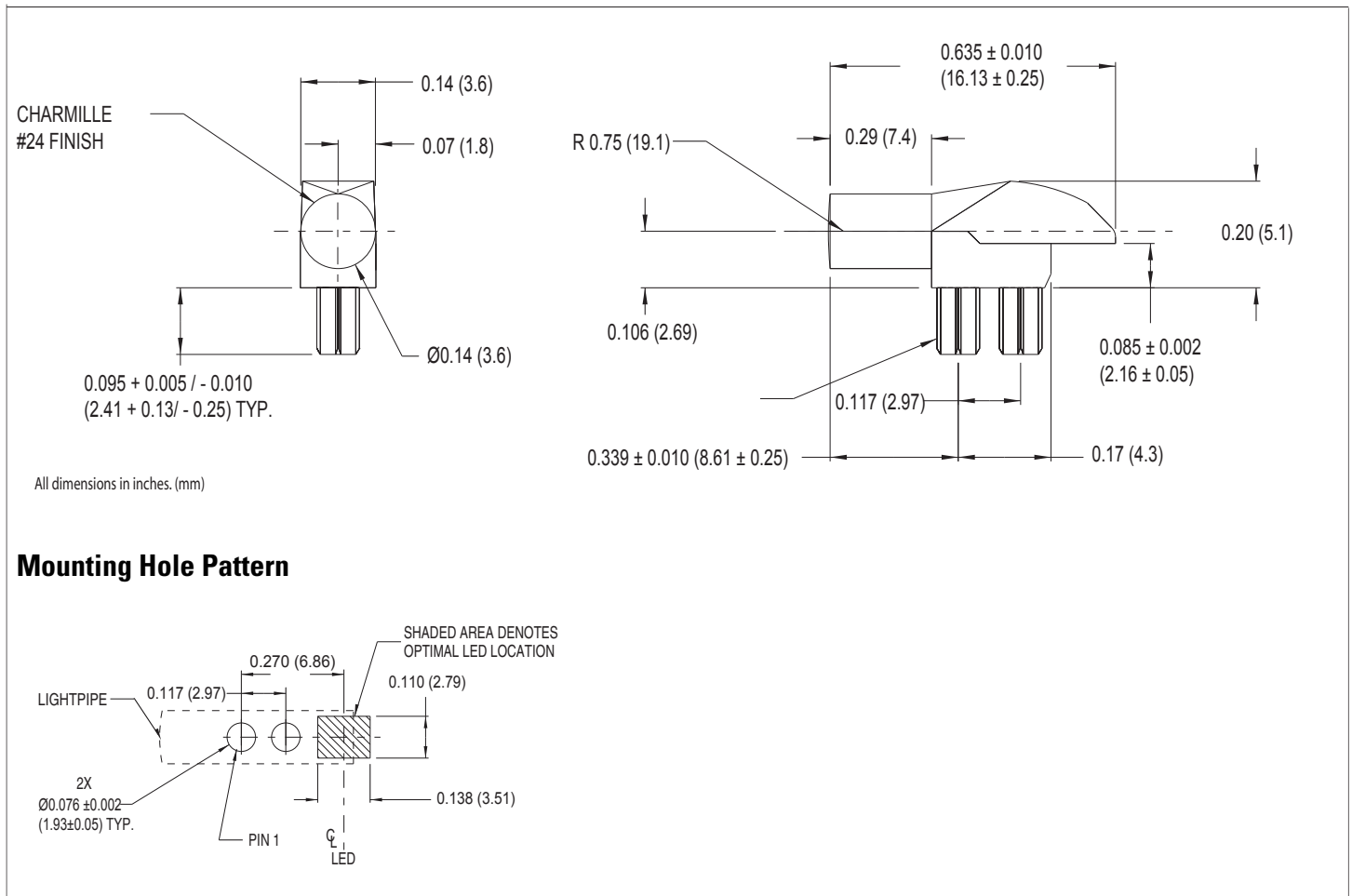

- Precision engineered with **ray tracing** for bright, optically precise even indication and attractive appearance.
- ESD protection from circuitry for exceptional reliability.
- High contrast and wide viewing angle for greater visibility.
- Available in a variety of colors for added contrast and aesthetics.
- Parts inserted after reflow to permit LED pad inspection before assembly.
- Compliance to UL94V-0
- Low profile for height constrained applications.
- Large lens provides high visibility.
- 7513D2-L is designed for use with CMD67-21 and CMD67-22 Series LEDs
- RoHS Compliant

Mouser Electronics

Authorized Distributor

Click to View Pricing, Inventory, Delivery & Lifecycle Information:

VCC:

[7513D2-L](#)