

High density power driver - high voltage full bridge with integrated comparators

VFQFPN 15 x 7 x 1 mm

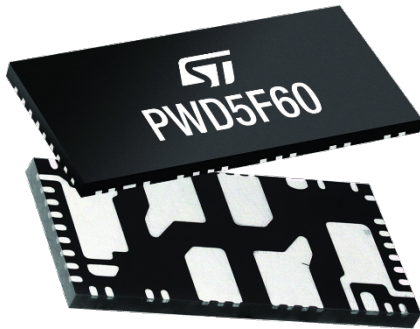

Features

- Power system-in-package integrating gate drivers and high-voltage power MOSFETs
 - $R_{DS(ON)} = 1.38 \Omega$
 - $BV_{DSS} = 600 V$
- Suitable for operating as
 - full bridge
 - dual independent half bridges
- UVLO protection on low-side and high-side
- 3.3 V to 15 V compatible inputs with hysteresis and pull-down
- Internal bootstrap diode
- Uncommitted comparators
- Adjustable dead-time
- Bill of material reduction
- Very compact and simplified layout
- Flexible, easy and fast design

Applications

- Industrial fans and pumps
- Cooking hoods and gas heaters
- Blowers
- Industrial drives and factory automation
- Power supply units

Product status link
[PWD5F60](#)

Product summary

Marking	PWD5F60
Package	VFQFPN 15x7x1mm
Order codes	
PWD5F60	Tray
PWD5F60TR	Tape and Reel

Description

The PWD5F60 is an advanced power system-in package integrating gate drivers and four N-channel power MOSFETs in dual half-bridge configuration.

The integrated power MOSFETs have $R_{DS(ON)}$ of 1.38 Ω and 600 V drain-source breakdown voltage, while the embedded gate drivers high side can be easily supplied by the integrated bootstrap diode. The high integration of the device allows to efficiently drive loads in a tiny space.

The PWD5F60 accepts a supply voltage (VCC) extending over a wide range (10 V to 20 V) and also features UVLO protection on both the lower and upper driving sections, preventing the power switches from operating in low efficiency or dangerous conditions.

The input pins extended range allows easy interfacing with microcontrollers, DSP units or Hall effect sensors.

The PWD5F60 embeds two uncommitted comparators available for protections against overcurrent, overtemperature, etc.

The PWD5F60 operates in the industrial temperature range, -40 °C to 125 °C.

The device is available in a compact VFQFPN package.

1 Block diagram

Figure 2. Block diagram

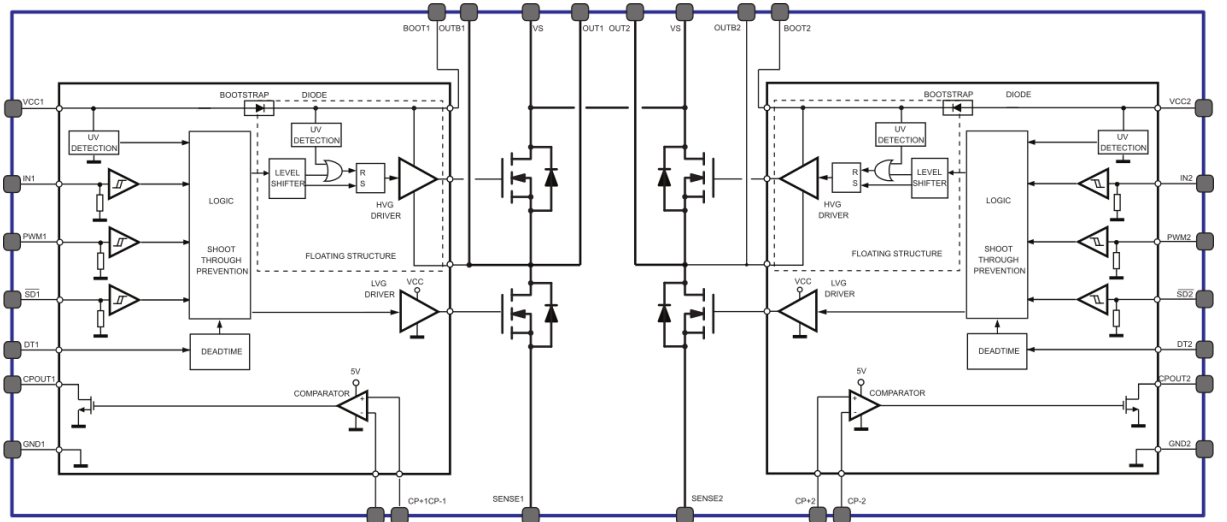

2 Pin description and connection diagram

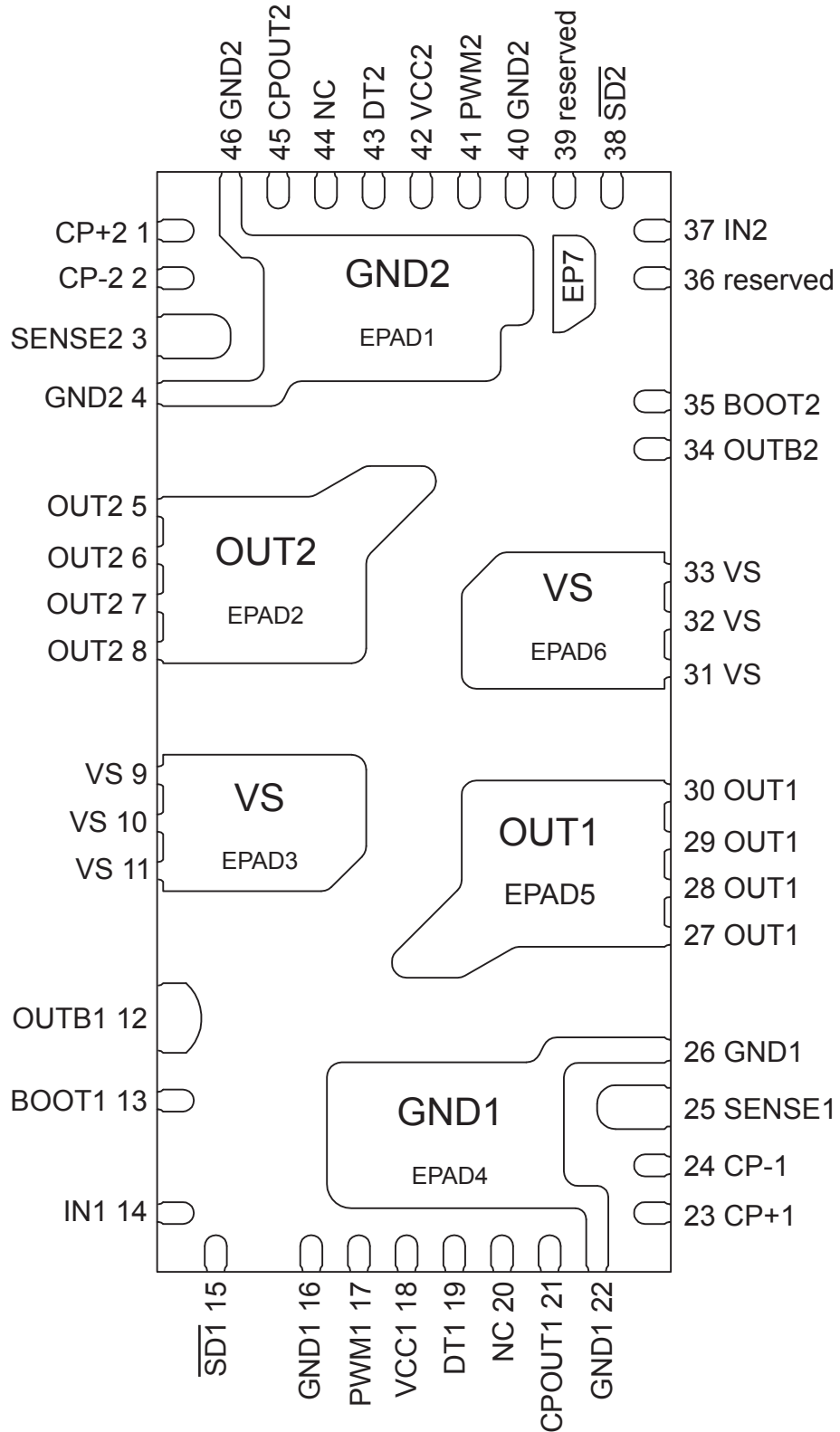
Figure 3. Pin connection (top view)

2.1 Pin list

Table 1. Pin description

Pin number	Pin name	Type	Function
9, 10, 11, 31, 32, 33, EPAD3, EPAD6	VS	Power Supply	High voltage supply (high-side MOSFET Drain) ⁽¹⁾
27, 28, 29, 30, EPAD5	OUT1	Power Output	Half-bridge 1 output
5, 6, 7, 8, EPAD2	OUT2	Power Output	Half-bridge 2 output
12	OUTB1	Power supply	Half-bridge 1 output connection for high-side supply capacitor ⁽²⁾
34	OUTB2	Power supply	Half-bridge 2 output connection for high-side supply capacitor ⁽³⁾
25	SENSE1	Power Supply	Half-bridge 1 sense (low-side MOSFET Source)
3	SENSE2	Power Supply	Half-bridge 2 sense (low-side MOSFET Source)
13	BOOT1	Power Supply	Gate driver 1 high-side supply voltage
35	BOOT2	Power Supply	Gate driver 2 high-side supply voltage
18	VCC1	Power Supply	Gate driver 1 supply voltage
42	VCC2	Power Supply	Gate driver 1 supply voltage
16, 22, 26, EPAD4	GND1	Power Supply	Gate driver 1 ground
4, 40, 46, EPAD1	GND2	Power Supply	Gate driver 2 ground
14	IN1	Logic Input	Driver 1 logic input
37	IN2	Logic Input	Driver 2 logic input
15	$\overline{SD1}$	Logic Input	Driver 1 shut down input (active low)
38	$\overline{SD2}$	Logic Input	Driver 2 shut down input (active low)
17	PWM1	Logic Input	Driver 1 PWM input
41	PWM2	Logic Input	Driver 2 PWM input
19	DT1	Input	Driver 1 dead time setting
43	DT2	Input	Driver 2 dead time setting
21	CPOUT1	Output	Comparator 1 output (open drain)
45	CPOUT2	Output	Comparator 2 output (open drain)
23	CP+1	Input	Comparator 1 positive input
1	CP+2	Input	Comparator 2 positive input
24	CP-1	Input	Comparator 1 negative input
2	CP-2	Input	Comparator 2 negative input
36, 39, EPAD7	reserved	Reserved	Not connected
20, 44,	NC	Reserved	Not connected

1. EPAD3 is internally connected with EPAD6. No connection is required at PCB level.
2. Pin 12 is internally connected to OUT1. No connection is required at PCB level.
3. Pin 34 is internally connected to OUT2. No connection is required at the PCB level. Use pin 34 for bootstrap capacitor connection only.

3 Electrical data

3.1 Absolute maximum ratings

Table 2. Absolute maximum ratings

Symbol	Parameter	Test Condition	Value	Unit
V_{DS}	MOSFET Drain-to-Source Voltage	$T_J = 25\text{ °C}$	600	V
V_{CC1}, V_{CC2}	Drivers supply voltage	-	-0.3 to 20	V
$V_{CCx-SENSEx}$	V_{CCx} to $SENSEx$ pin voltage	-	-0.3 to 25	V
V_{BOOTx}	Bootstrap voltage	-	$GNDx-0.3$ to 600	V
V_{BO1}, V_{BO2}	$BOOTx$ to $OUTx$ pin voltage	-	-0.3 to 20	V
V_{CP+x}, V_{CP-x}	Comparator input pin voltage	-	-0.3 to $V_{CCx}+0.3$	V
V_{CPOUTx}	Comparator open-drain output voltage	-	-0.3 to 15	V
I_D	Drain current (per MOSFET)	DC @ $T_{CB} = 25\text{ °C}$ ⁽¹⁾	3.5	A
		DC @ $T_{CB} = 100\text{ °C}$ ^{(1) (2)}	2	A
		Peak @ $T_{CB} = 25\text{ °C}$ ^{(1) (2) (3)}	14	A
SR_{OUT}	Full-bridge outputs slew rate (10% - 90%) ⁽²⁾		40	V/ns
V_i	Logic inputs voltage range	-	-0.3 to 15	V
T_J	Junction temperature	-	-40 to 150	°C
T_s	Storage temperature	-	-40 to 150	°C
P_{tot}	Total power dissipation ⁽⁴⁾	$T_{CB} = 25\text{ °C}$ for each MOSFET	43	W
		$T_{amb} = 25\text{ °C}$, whole device, device mounted on an FR4 2s2p board as per JESD51-5,7. See Table 4.. ⁽⁵⁾	5	W
ESD	Human body model	-	±1500	V
	Charged device model	-	±500	V

1. T_{CB} is temperature of case bottom pad.

2. Characterized, not tested in production.

3. The value specified by design factor, pulse duration limited by max junction temperature and SOA.

4. Value calculated based on thermal resistance, power uniformly distributed over the four power MOSFETs, still air.

5. Actual applicative board max dissipation could be higher or lower depending on layout and cooling techniques.

3.2 Recommended operating conditions

Table 3. Recommended operating conditions

Symbol	Pin	Parameter	Test Condition	Min.	Max.	Unit
V_{CC1}, V_{CC2}	$V_{CCx} - GNDx$	Driver Supply voltage	-	10	20	V
V_{BO1}, V_{BO2}	$BOOTx - OUTx$	$BOOTx$ to $OUTx$ pin voltage	-	9.8	20	V
V_{CP-x}	CP-x	Comparator negative input voltage	$V_{CP+} \leq 2.5\text{ V}$	-	V_{CCx} ⁽¹⁾	V

Symbol	Pin	Parameter	Test Condition	Min.	Max.	Unit
V_{CP+x}	CP+x	Comparator positive input voltage	$V_{CP-} \leq 2.5 \text{ V}$	-	$V_{CCx}^{(1)}$	V
T_J	-	Junction temperature	-	-40	125	°C

1. At least one of the comparator inputs must be lower than 2.5 V to guarantee proper operation.

3.3 Thermal data

Table 4. Thermal data

Symbol	Parameter	Value	Unit
$R_{th(J-CB)}$	Thermal resistance junction to each MOSFET exposed pad, typical	2.85	°C/W
$R_{th(J-A)}$	Thermal resistance junction-to-ambient ⁽¹⁾	25	°C/W

1. The junction to ambient thermal resistance is obtained simulating the device mounted on a 2s2p (4-layer) FR4 board as per JESD51-5,7 with 4 thermal vias for each MOSFET pad. Power dissipation is uniformly distributed over the four power MOSFETs.

4 Electrical characteristics

4.1 Driver

VCCx = 15 V; T_J = 25 °C, unless otherwise specified.

Table 5. Driver electrical characteristics

Symbol	Pin	Parameter	Test condition	Min.	Typ.	Max	Unit
Low supply voltage section							
VCC_hys	VCCx vs. GNDx	VCC UV hysteresis	-	1.2	1.5	1.8	V
VCC_thON		VCC UV turn ON threshold	-	9	9.5	10	V
VCC_thOFF		VCC UV turn OFF threshold	-	7.6	8	8.4	V
I _{qccu}		Undervoltage quiescent supply current	VCC = 7 V; SD = 5 V; IN = PWM = GND; R _{DT} = 0 Ω; CP+ = GND; CP- = 0.5 V	-	110	150	μA
I _{qcc}		Quiescent current	VCC = 15 V; SD = 5 V; IN = PWM = GND; R _{DT} = 0 Ω; CP+ = GND; CP- = 0.5 V	-	600	1000	μA
Bootstrapped supply voltage section							
V _{BO_hys}	BOOTx vs. OUTx	V _{BO} UV hysteresis	-	0.8	1.0	1.2	V
V _{BO_thON}		V _{BO} UV turn ON threshold	-	8.2	9	9.8	V
V _{BO_thOFF}		V _{BO} UV turn OFF threshold	-	7.3	8	8.7	V
I _{QBOU}		Undervoltage V _{BO} quiescent current	V _{BO} = 7 V	-	40	100	μA
I _{QBO}		V _{BO} quiescent current	V _{BO} = 15 V IN = PWM = SD = 5 V;	-	140	220	μA
R _{BD(on)}	VCCx vs. BOOTx	Bootstrap driver on resistance (1)	IN = GND; PWM = SD = 5 V;	-	120	-	Ω
Logic inputs							
V _{il}	INx, PWMx, SDx	Logic level Low threshold voltage	-	0.8	-	1.1	V
V _{ih}		Logic level High threshold voltage	-	1.9	-	2.3	V
I _{ih}		Logic '1' input bias current	IN = PWM = SD = 15 V	10	40	100	μA
I _{il}		Logic '0' input bias current	IN = PWM = SD = GND	-	-	1	μA
R _{in_pd}		Logic Inputs pull-down resistor	IN = PWM = SD = 15 V	0.18	0.37	1.5	MΩ
Comparator							
V _{io}	CP-x, CP+x vs. GNDx	Input offset voltage	V _{CP-} = 0.5 V	-16	-	+16	mV
I _{ib}		Input bias current	V _{CP+} = 1 V, V _{CP-} = 1 V	-	-	1	μA

Symbol	Pin	Parameter	Test condition	Min.	Typ.	Max	Unit
t_{d_comp}	CP+x to CPOUTx	Comparator delay	$R_{pu} = 100\text{ k}\Omega$ to 5 V $V_{CP-} = 0.5\text{ V}$; Voltage step on CP+ = 0 to 3.3 V; 50% CP+ to 90% CPOUT	-	90	130	ns
I_{OD}	CPOUTx	Open-drain low level sink current	CPOUT = 400 mV, $V_{CP+} = 1\text{ V}$, $V_{CP-} = 0.5\text{ V}$	2.4	-	-	mA
I_{ODlk}		Open-drain leakage current	CPOUT = 15 V, $V_{CP+} = 0\text{ V}$, $V_{CP-} = 0.5\text{ V}$	-	-	1	μA
SR_{CPOUT}	CPOUTx	Comparator output slew rate	$C_L = 180\text{ pF}$ $R_{pu} = 5\text{ k}\Omega$ to 5 V CPOUT from 90% to 10%	-	60	-	V/ μs
Dead time							
DT	DTx	Dead time setting range ⁽³⁾	$R_{DT} = 0$	0.1	0.18	0.25	μs
			$R_{DT} = 37\text{ k}\Omega$, $C_{DT} = 100\text{ nF}$	0.48	0.6	0.72	
			$R_{DT} = 136\text{ k}\Omega$, $C_{DT} = 100\text{ nF}$	1.35	1.6	1.85	
			$R_{DT} = 260\text{ k}\Omega$, $C_{DT} = 100\text{ nF}$	2.6	3.0	3.4	
MDT		Matching dead time ⁽³⁾ ⁽⁴⁾	$R_{DT} = 0$	-	-	80	ns
			$R_{DT} = 37\text{ k}\Omega$, $C_{DT} = 100\text{ nF}$	-	-	120	
			$R_{DT} = 136\text{ k}\Omega$, $C_{DT} = 100\text{ nF}$	-	-	250	
			$R_{DT} = 260\text{ k}\Omega$, $C_{DT} = 100\text{ nF}$	-	-	400	

- $R_{BD(on)}$ is tested in the following way: $R_{BD(on)} = [(VCC - V_{BOOTa}) - (VCC - V_{BOOTb})] / [I_a - I_b]$, where: I_a is BOOT pin current when $V_{BOOT} = V_{BOOTa}$; I_b is BOOT pin current when $V_{BOOT} = V_{BOOTb}$.
- The comparator is disabled when VCC is in UVLO condition.
- Tested at wafer level before packaging
- $MDT = |DTLH - DTHL|$.

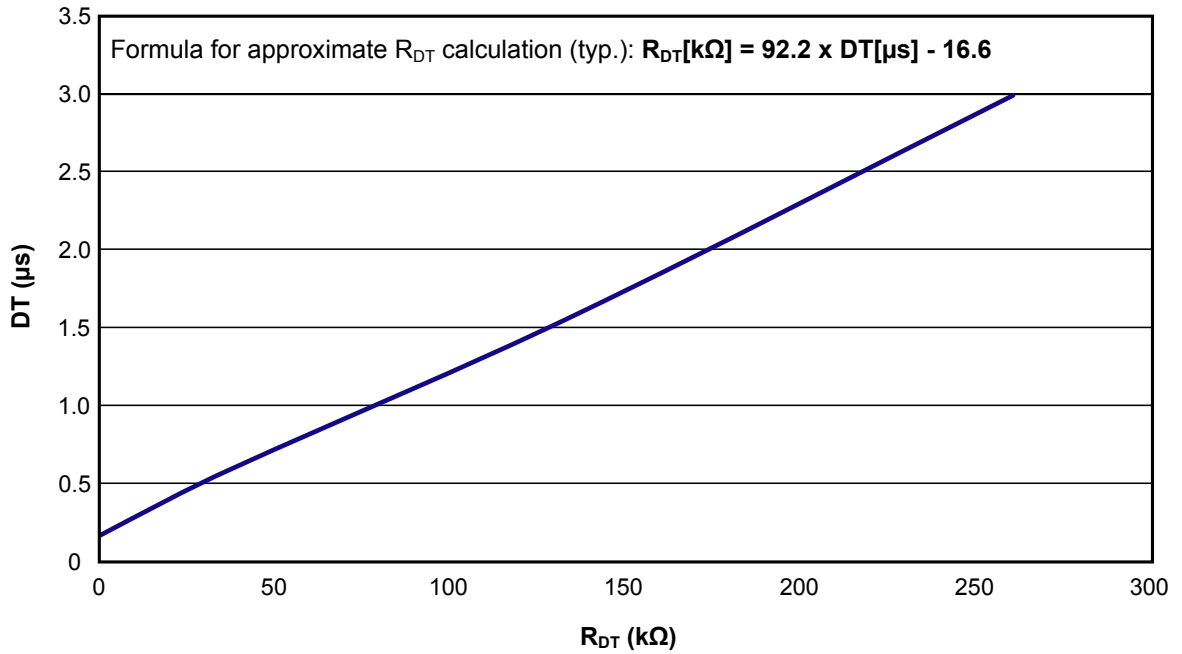
Figure 4. Typical dead time vs. R_{DT} resistor value

4.2 Power MOSFET

VCCx = 15 V; $T_J = 25^\circ\text{C}$, unless otherwise specified.

Table 6. Power MOSFET electrical characteristics

Symbol	Parameter	Test condition	Min	Typ	Max	Unit
MOSFET on/off states						
$V_{(BR)DS}$	Drain-source breakdown voltage	$I_D = 1 \text{ mA}^{(1)}$	600	-	-	V
I_{DSS}	Zero gate voltage drain current	$V_{DS} = 600 \text{ V}$ $\overline{SD} = \text{SENSE} = \text{GND}$	-	-	1	μA
$V_{GS(th)}$	Gate threshold voltage	$V_{DS} = V_{GS}$, $I_D = 250 \mu\text{A}^{(1)}$	3	4	5	V
$R_{DS(on)}$	Static drain-source on-resistance	$I_D = 1.75 \text{ A}$; $V_{GS} = 10 \text{ V}$;	-	1.38	1.75	Ω
MOSFET Avalanche						
I_{AS}	Avalanche current, repetitive or not repetitive	pulse width limited by $T_J \text{ max}^{(1)}$	-	-	1	A
E_{AS}	Single pulse avalanche energy	Starting $T_J = 25^\circ\text{C}$, $I_D = I_{AS}$, $V_{DD} = 50 \text{ V}^{(1)}$	-	-	132	mJ
Source-Drain diode						
V_{SD}	Diode forward on voltage	$\overline{SD} = \text{SENSE} = \text{GND}$ $I_{SD} = 3.5 \text{ A}$;	-	-	1.6	V

1. Tested at the wafer level before packaging.

5 Device characterization values

Table 7., Table 8. and the electrical characteristics curves (from Figure 6. to Figure 15.) represent typical values based on characterization and simulation results and are not subject to production tests.

Table 7. Power MOSFET characterization values

Symbol	Parameter	Test condition	Min	Typ	Max	Unit
MOSFET Dynamic						
Q_g	Total gate charge	$V_{GS} = 10\text{ V}$, $T_J = 25\text{ °C}$ $V_{DS} = 480\text{ V}$, $I_D = 3.5\text{ A}$	-	5.3	-	nC
Source-Drain diode						
t_{rr}	Diode reverse recovery time	$I_{SD} = 3.5\text{ A}$, $T_J = 25\text{ °C}$ $di/dt = 100\text{ A}/\mu\text{s}$, $V_{DS} = 60\text{ V}$	-	58	-	ns
Q_{rr}	Diode reverse recovery charge		-	109	-	μC
I_{RRM}	Diode reverse recovery current		-	4	-	A
t_{rr}	Diode reverse recovery time	$I_{SD} = 3.5\text{ A}$, $T_J = 150\text{ °C}$ $di/dt = 100\text{ A}/\mu\text{s}$, $V_{DS} = 60\text{ V}$	-	109	-	ns
Q_{rr}	Diode reverse recovery charge		-	309	-	μC
I_{RRM}	Diode reverse recovery current		-	5	-	A

Table 8. Inductive load switching characteristics

Symbol	Parameter	Test condition	Min	Typ	Max	Unit
$t_{(on)}^{(1)}$	Turn-on time	$V_S = 300\text{ V}$, $V_{CC} = V_{BO} = 15\text{ V}$, $I_D = 1.75\text{ A}$ See Figure 5.	-	450	-	ns
$t_{C(on)}^{(2)}$	Crossover time (on)		-	67	-	ns
$t_{(off)}^{(1)}$	Turn-off time		-	171	-	ns
$t_{C(off)}^{(2)}$	Crossover time (off)		-	25	-	ns
t_{SD}	Shutdown to high/low-side propagation delay		-	165	-	ns
E_{on}	Turn-on switching losses		-	51	-	μJ
E_{off}	Turn-off switching losses		-	3	-	μJ

- $t_{(on)}$ and $t_{(off)}$ include the propagation delay time of the internal driver
- $t_{C(on)}$ and $t_{C(off)}$ are the switching times of MOSFET itself under the internally given gate driving conditions

Figure 5. Switching time definition

Figure 6. Normalized gate threshold voltage vs. temperature

Figure 7. Normalized drain-source breakdown voltage vs. temperature

Figure 8. Static drain-source on-resistance

Figure 9. Normalized on-resistance vs temperature

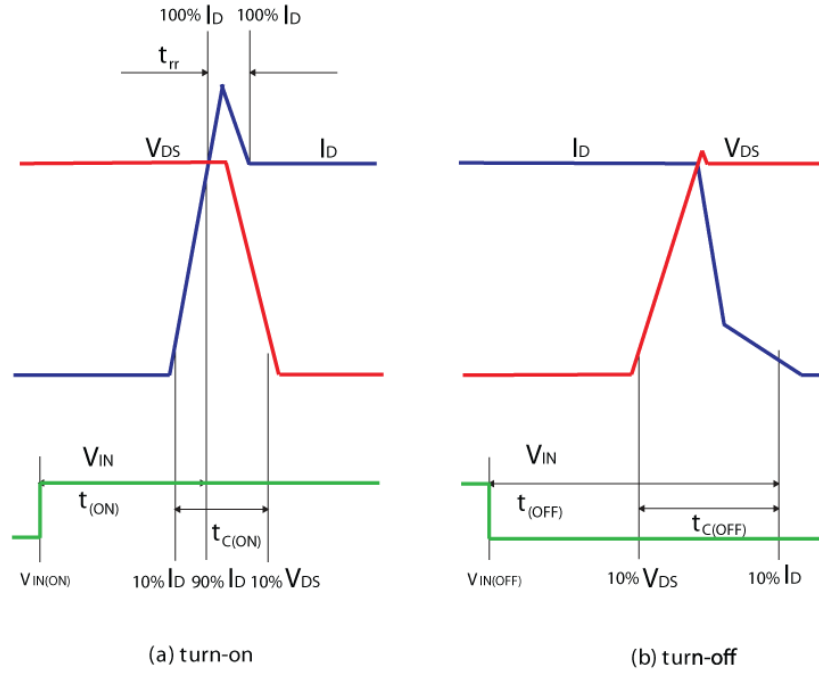
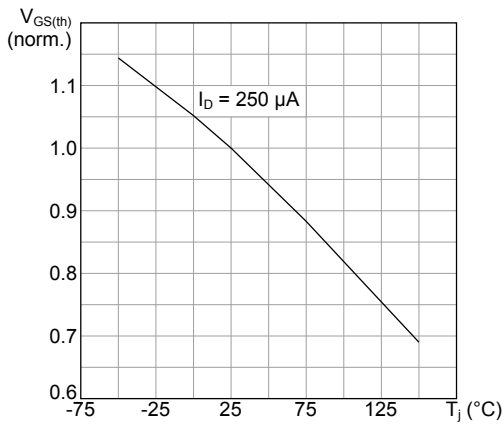
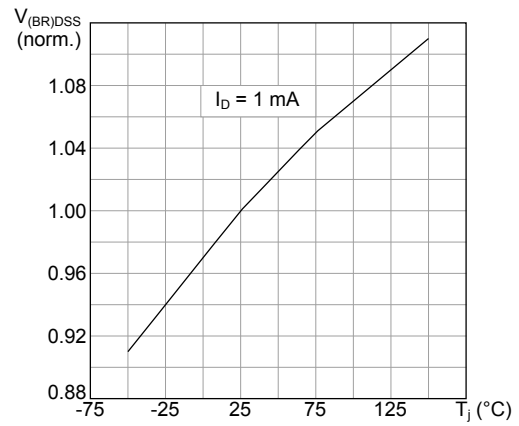
Figure 10. Transfer characteristics

Figure 11. Output characteristics

Figure 12. Static source-drain diode forward characteristics

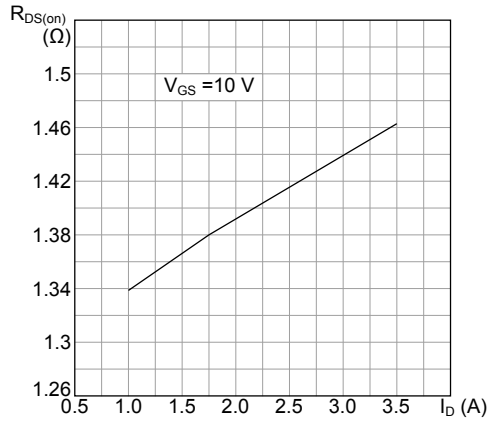
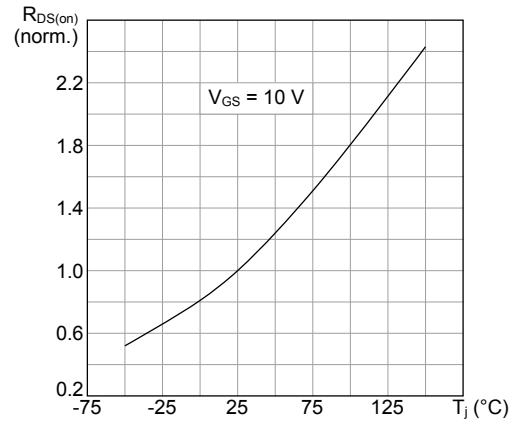
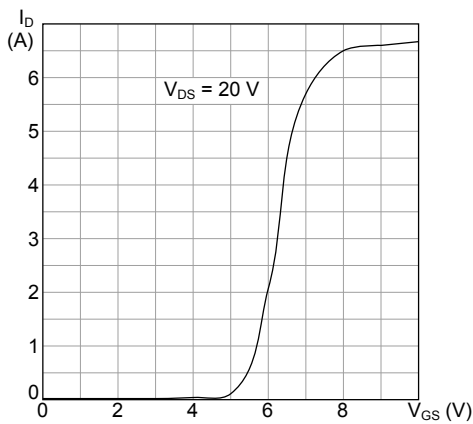
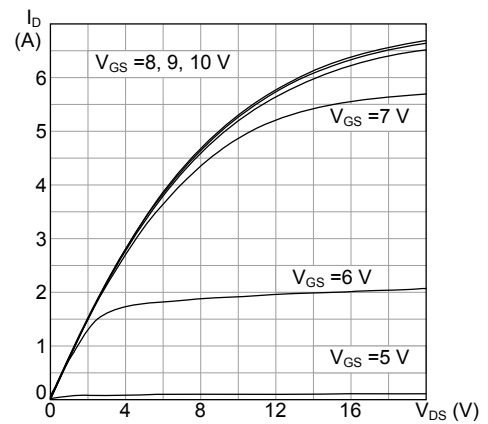
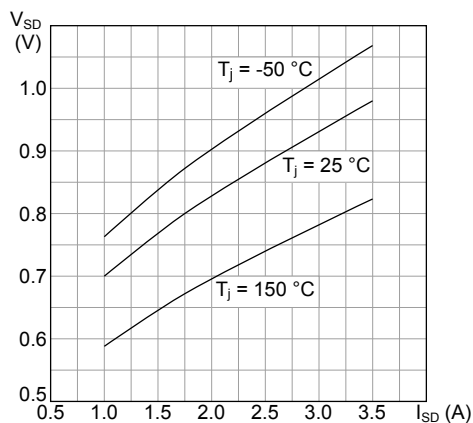
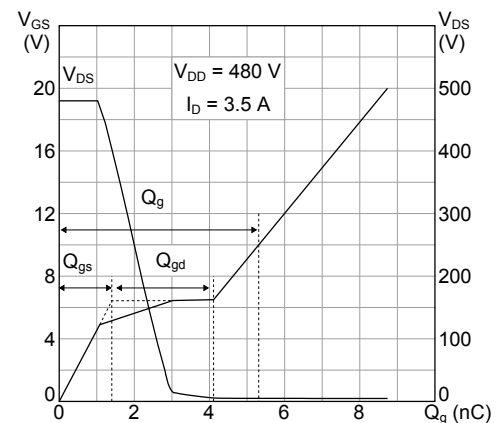
Figure 13. Gate charge vs. gate-source voltage

Figure 14. MOSFET capacitance variations

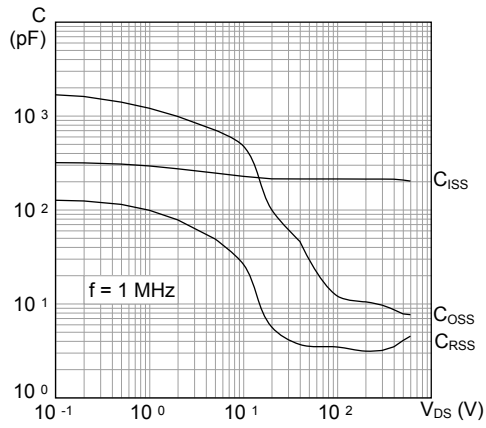
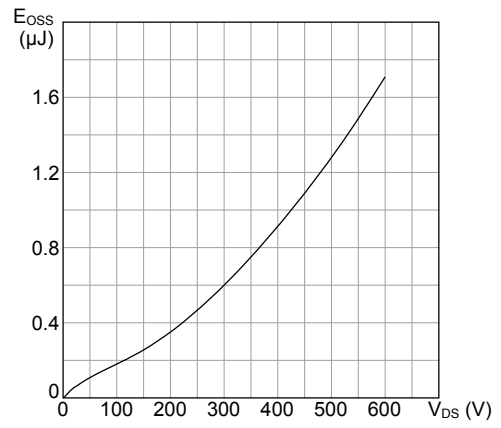

Figure 15. MOSFET output capacitance stored energy



6 Functional description

6.1 Logic inputs

The PWD5F60 full bridge features two identical half-bridge sections. Each section has three logic inputs to control the internal high-side and low-side MOSFETs.

Table 9. Truth table

Inputs			Outputs	
SD	IN	PWM	HS	LS
0	X	X	OFF	OFF
1	0	0	OFF	ON
1	0	1	OFF	ON
1	1	0	OFF	ON
1	1	1	ON	OFF

The logic inputs have internal pull-down resistors. The purpose of these resistors is to set a defined logic level if, for example, there is an interruption on the logic lines or the controller outputs are in tri-state conditions.

6.2 Bootstrap structure

Bootstrap circuitry is typically used to supply the high-voltage section. This function is normally accomplished with a high-voltage fast recovery diode, as shown in Figure 16. (side a).

In the PWD5F60, a patented integrated structure replaces the external diode. The structure consists of a series of low-voltage diodes and a high-voltage DMOS, driven synchronously by the low-side driver (LVG), as shown in Figure 16. (side b). An internal bootstrap provides the DMOS driving voltage. The integrated diode structure is actively turned on and guarantees best performance only when the low-side driver is on.

In applications where the control strategy requires recharging the bootstrap capacitor even when the low-side driver is off, the use of an external bootstrap diode in parallel to the integrated structure is possible.

Figure 16. Bootstrap structure

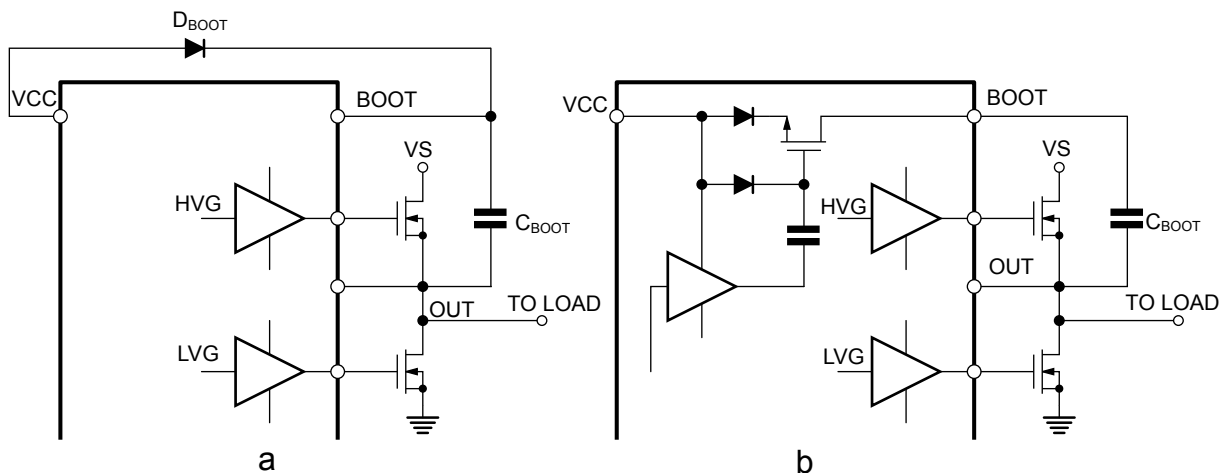

6.3 Supply pins and UVLO function

The VCCx supply pin supplies current to the low-side section of the gate driver and to the integrated bootstrap diode used to charge the bootstrap capacitor. During output commutations, the average current used to provide gate charge to the high-side and low-side MOSFETs flow through these pins.

The VCC1 and VCC2 pins separately supply power to the two drivers, even if they are usually connected together at the power supply in final applications.

The PWD5F60 VCCx supply voltage is continuously monitored by undervoltage lockout (UVLO) circuits that turn the high-side and low-side MOSFETs off when the supply voltage falls below the V_{CC_thOFF} threshold. The VCCx UVLO circuitry turns on the high-side or low-side MOSFET according to the input status as soon as the supply voltage rises above the V_{CC_thON} voltage. V_{CC_hys} hysteresis is provided for noise rejection purposes.

Two separate UVLO circuits monitor VCC1 and VCC2 so that when a UVLO occurs on a single rail, only the corresponding half bridge MOSFETs are turned off.

The PWD5F60 V_{BO} supply voltages are also continuously monitored by two dedicated V_{BO} UVLO circuits that turn the corresponding high-side MOSFET off when the supply voltage falls below the V_{BO_thOFF} threshold. The UVLO circuitry allows turning the high-side MOSFET on again, according to input edges, as soon as the V_{BO} supply voltage rises above the V_{BO_thON} voltage. A V_{BO_hys} hysteresis is provided for noise rejection purposes.

6.4 Dead time

The PWD5F60 automatically inserts a DT dead time on each half bridge. This avoids shoot-through as a MOSFET gate discharges completely before charging starts on the other MOSFET gate.

The DT value is set by the resistor placed between the DTx pin and GNDx, as shown in [Figure 4.](#)

The minimum dead time value set with a 0 Ω resistor is normally sufficient to avoid shoot-through between high side and low side.

Some applications, like those operating with soft turn-on commutations at low current seeking maximum efficiency, might benefit from a longer dead time. The PWD5F60 lets you set the dead time for each half bridge for maximum flexibility.

7 Typical application diagrams

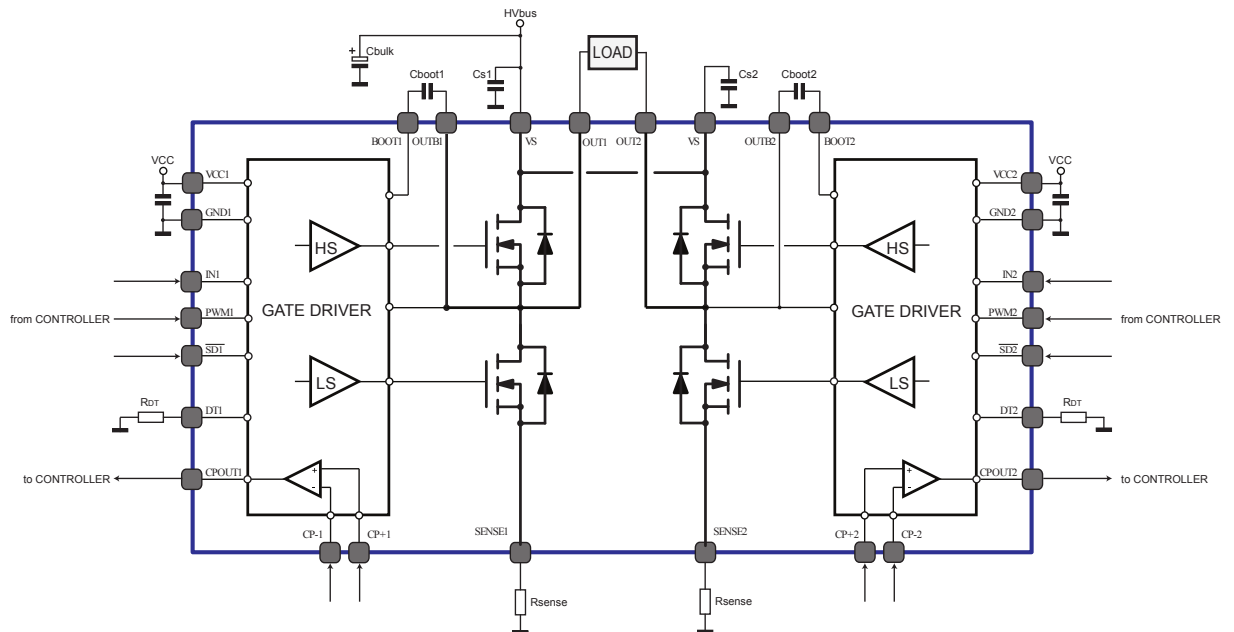
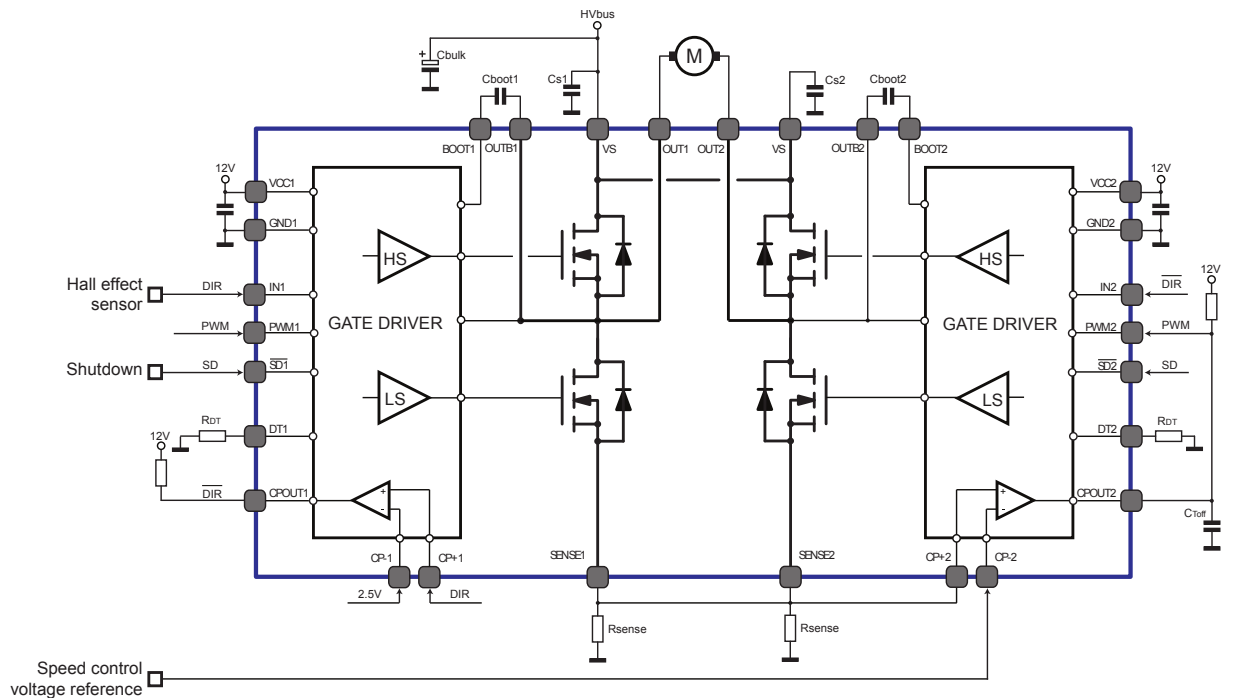
Figure 17. Generic application

Figure 18. Current mode motor control

8 Package information

In order to meet environmental requirements, ST offers these devices in different grades of ECOPACK® packages, depending on their level of environmental compliance. ECOPACK® specifications, grade definitions and product status are available at: www.st.com. ECOPACK® is an ST trademark.

8.1 VFQFPN 15 x 7 x 1 mm package information

The package outline CAD file is available upon request.

Figure 19. VFQFPN 15 x 7 x 1 mm package dimensions – drawing top and side view

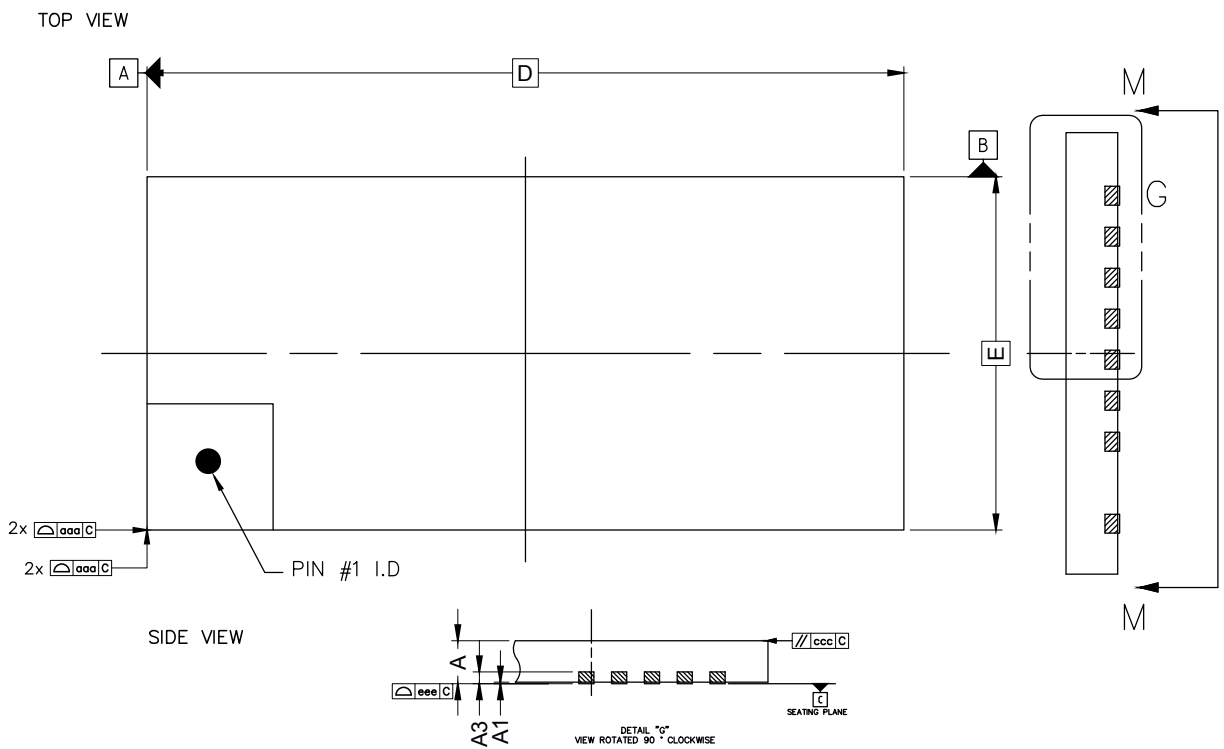
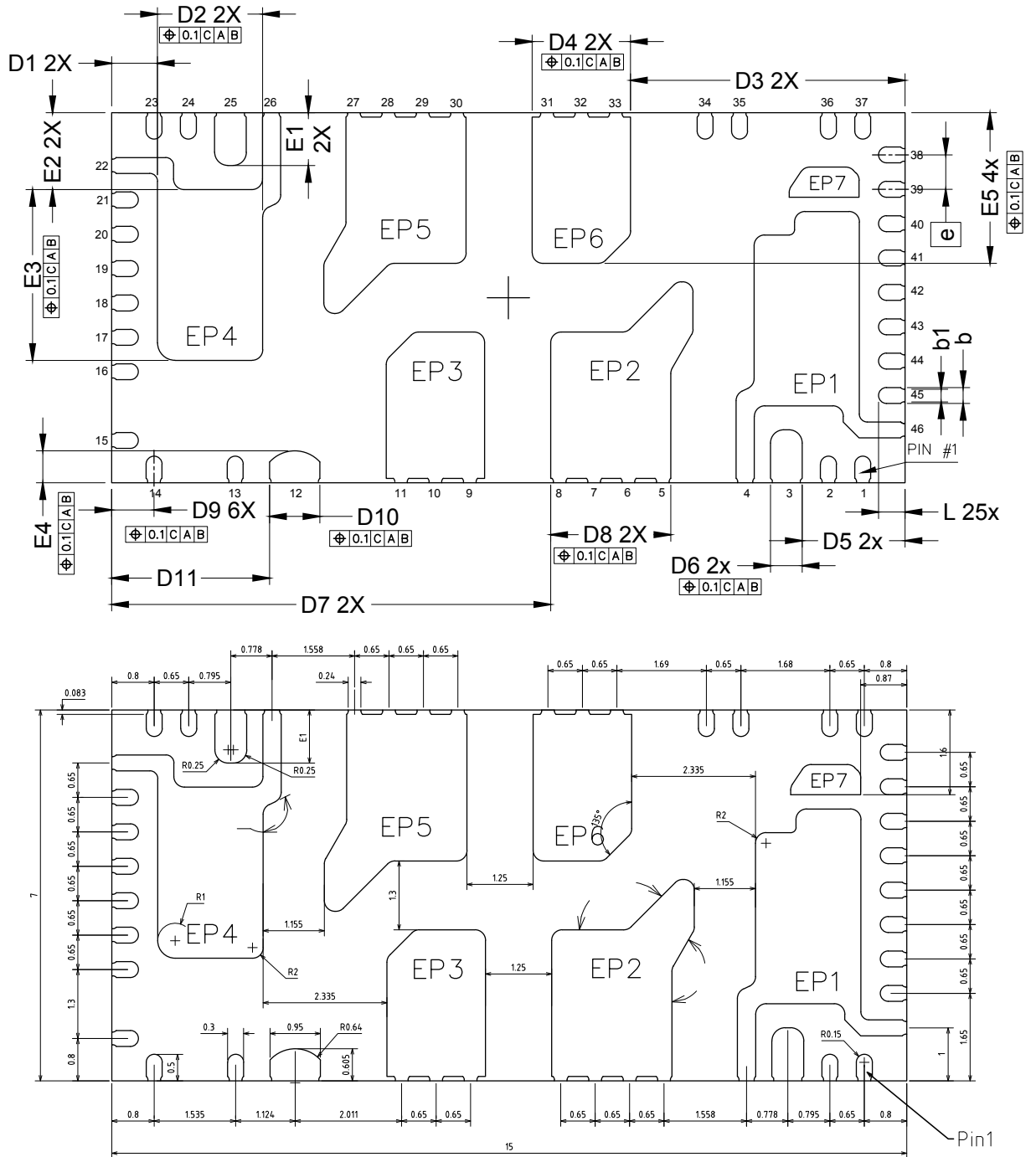
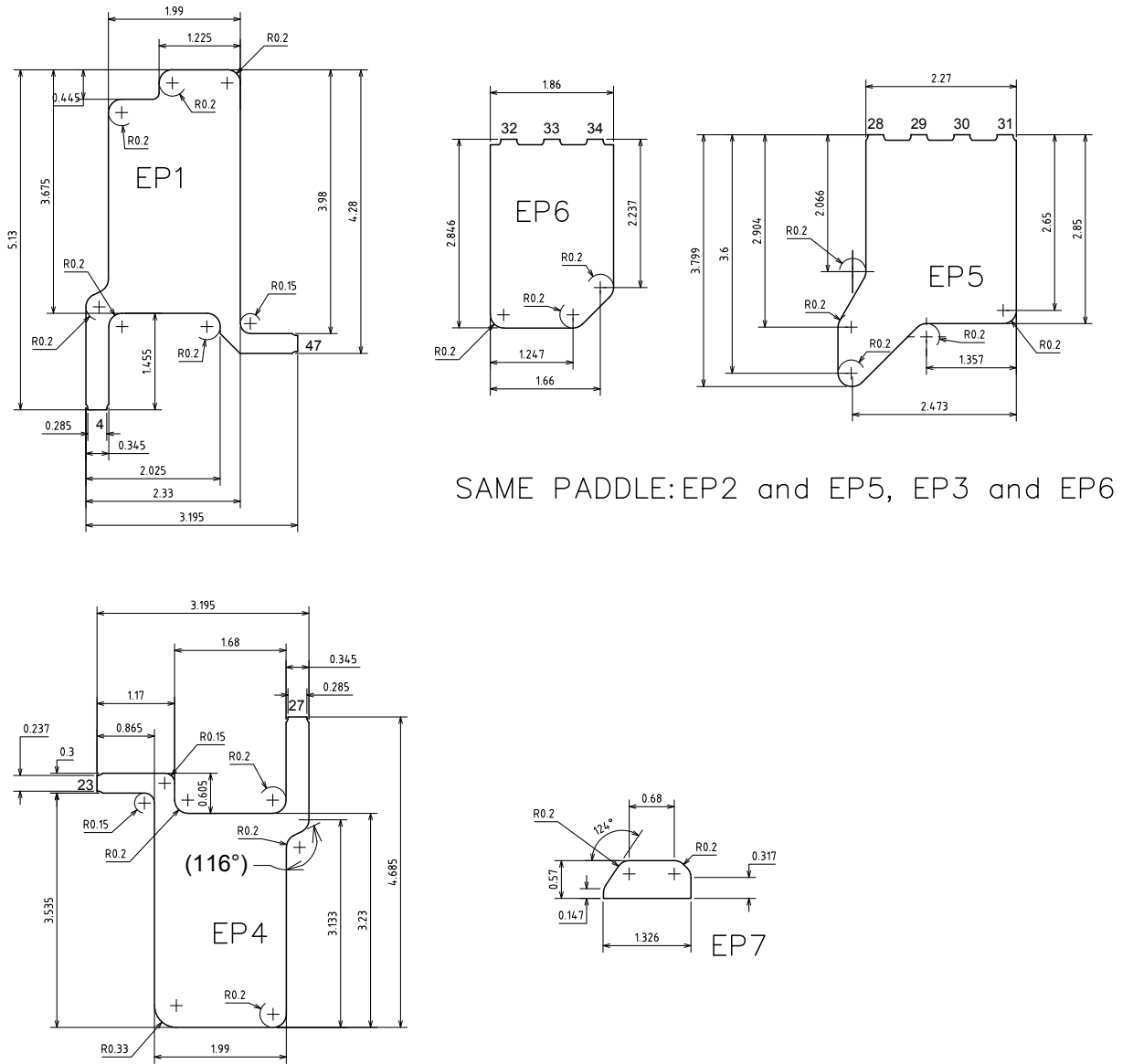

Figure 20. VFQFPN 15 x 7 x 1 mm package dimensions – drawing bottom view



SAME PADDLE: EP2 and EP5, EP3 and EP6

Figure 21. VFQFPN 15 x 7 x 1 mm package dimensions – exposed pads details

Table 10. VFQFPN 15 x 7 x 1 mm package mechanical data

Symbol	Dimensions (mm)		
	Min.	Typ.	Max.
A	0.80	0.85	0.90
A1	0.00		0.05
A3		0.20	
b	0.20	0.30	0.40
b1	0.14	0.24	0.34
D	14.90	15.00	15.10
E	6.90	7.00	7.10
D1		0.865	

Symbol	Dimensions (mm)		
	Min.	Typ.	Max.
D2	1.89	1.99	2.09
D3	5.10		
D4	1.70	1.86	1.90
D5	1.945		
D6	0.50	0.60	0.70
D7	8.30		
D8	2.17	2.27	2.37
D9	0.70	0.80	0.90
D10	0.85	0.95	1.05
D11	2.985		
D12	4.01		
D13	2.85		
D14	0.20	0.345	0.40
E1	0.90	1.00	1.10
E2	1.455		
E3	3.13	3.23	3.33
E4	0.505	0.605	0.705
E5	2.75	2.85	2.95
E6	3.70	3.80	3.90
L	0.40	0.50	0.60
e	0.65		
R1	0.33		
R2	0.20		
R3	0.15		
aaa	0.10		
bbb	0.10		
ccc	0.10		
ddd	0.05		
eee	0.08		

Note:

- *VFQFPN stands for Thermally Enhanced Very thin Fine pitch Quad Flat Packages No lead.*
- *Dimensioning and tolerances comply with ASME Y14.5-2009.*
- *All dimensions are in millimetres.*
- *A variable pitch is applied on leads. Please refer to [Figure 20](#) for lead position details.*
- *The leads size is comprehensive of the thickness of the leads finishing material.*
- *Dimensions do not include mold protrusion, not to exceed 0.15 mm.*
- *Package outline does not include eventual metal burr dimensions.*

9 Ordering information

Table 11. Device summary

Order code	Package	Packaging
PWD5F60	VFQFPN 15 x 7 x 1 mm	Tray
PWD5F60TR	VFQFPN 15 x 7 x 1 mm	Tape and Reel

Revision history

Table 12. Document revision history

Date	Version	Changes
03-Jul-2018	1	Initial release.

Contents

1	Block diagram	2
2	Pin description and connection diagram	3
2.1	Pin list	3
3	Electrical data	5
3.1	Absolute maximum ratings	5
3.2	Recommended operating conditions	5
3.3	Thermal data	6
4	Electrical characteristics	7
4.1	Driver	7
4.2	Power MOSFET	9
5	Device characterization values	10
6	Functional description	14
6.1	Logic inputs	14
6.2	Bootstrap structure	14
6.3	Supply pins and UVLO function	14
6.4	Dead time	15
7	Typical application diagrams	16
8	Package information	17
8.1	VFQFPN 15 x 7 x 1 mm package information	17
9	Ordering information	21
	Revision history	22

List of figures

Figure 2.	Block diagram	2
Figure 3.	Pin connection (top view)	3
Figure 4.	Typical dead time vs. R_{DT} resistor value.	9
Figure 5.	Switching time definition	11
Figure 6.	Normalized gate threshold voltage vs temperature	11
Figure 7.	Normalized drain-source breakdown voltage vs. temperature	11
Figure 8.	Static drain-source on-resistance	12
Figure 9.	Normalized on-resistance vs temperature	12
Figure 10.	Transfer characteristics	12
Figure 11.	Output characteristics	12
Figure 12.	Static source-drain diode forward characteristics.	12
Figure 13.	Gate charge vs. gate-source voltage	12
Figure 14.	MOSFET capacitance variations	13
Figure 15.	MOSFET output capacitance stored energy	13
Figure 16.	Bootstrap structure	14
Figure 17.	Generic application	16
Figure 18.	Current mode motor control	16
Figure 19.	VFQFPN 15 x 7 x 1 mm package dimensions – drawing top and side view.	17
Figure 20.	VFQFPN 15 x 7 x 1 mm package dimensions – drawing bottom view.	18
Figure 21.	VFQFPN 15 x 7 x 1 mm package dimensions – exposed pads details	19

List of tables

Table 1.	Pin description	4
Table 2.	Absolute maximum ratings	5
Table 3.	Recommended operating conditions	5
Table 4.	Thermal data	6
Table 5.	Driver electrical characteristics	7
Table 6.	Power MOSFET electrical characteristics	9
Table 7.	Power MOSFET characterization values	10
Table 8.	Inductive load switching characteristics	10
Table 9.	Truth table	14
Table 10.	VFQFPN 15 x 7 x 1 mm package mechanical data	19
Table 11.	Device summary	21
Table 12.	Document revision history	22

IMPORTANT NOTICE – PLEASE READ CAREFULLY

STMicroelectronics NV and its subsidiaries (“ST”) reserve the right to make changes, corrections, enhancements, modifications, and improvements to ST products and/or to this document at any time without notice. Purchasers should obtain the latest relevant information on ST products before placing orders. ST products are sold pursuant to ST’s terms and conditions of sale in place at the time of order acknowledgement.

Purchasers are solely responsible for the choice, selection, and use of ST products and ST assumes no liability for application assistance or the design of Purchasers’ products.

No license, express or implied, to any intellectual property right is granted by ST herein.

Resale of ST products with provisions different from the information set forth herein shall void any warranty granted by ST for such product.

ST and the ST logo are trademarks of ST. All other product or service names are the property of their respective owners.

Information in this document supersedes and replaces information previously supplied in any prior versions of this document.

© 2018 STMicroelectronics – All rights reserved

Mouser Electronics

Authorized Distributor

Click to View Pricing, Inventory, Delivery & Lifecycle Information:

[STMicroelectronics:](#)

[PWD5F60TR](#) [PWD5F60](#)