

4.3inch HDMI LCD, 480×272

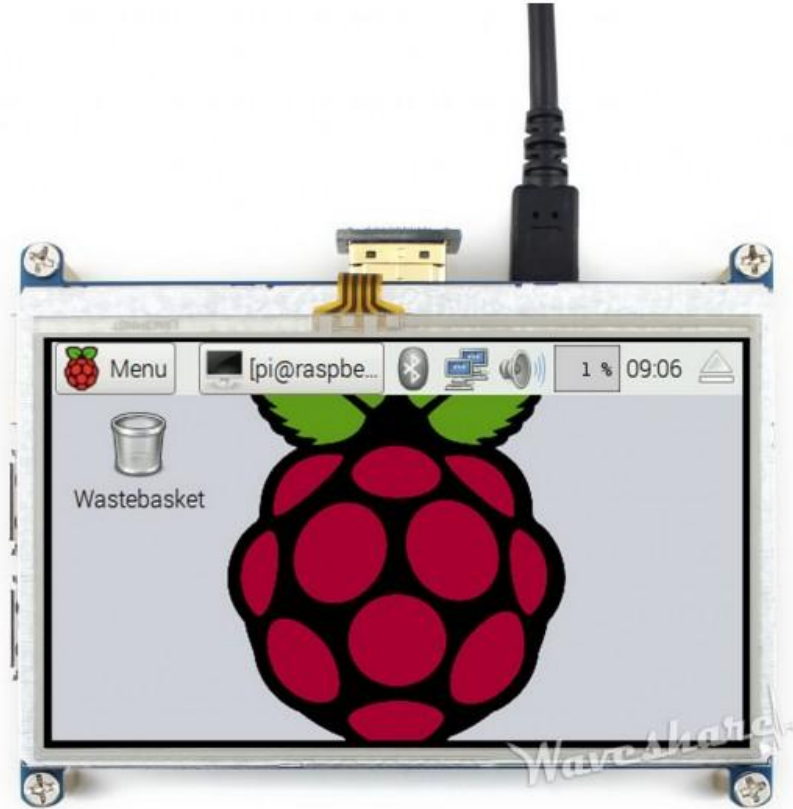

4.3inch Resistive Touch Screen LCD, HDMI interface, Designed for Raspberry Pi

Features

- 480×272 high resolution
- Resistive touch control
- Compatible and Direct-connect with any revision of Raspberry Pi (except the Pi 1 model B or Pi Zero, which requires an HDMI cable)
- Drivers provided (works with your own Raspbian/Ubuntu directly)
- HDMI interface for displaying, no I/Os required (however, the touch panel still needs I/Os)
- Back light control to lower power consumption

Photos



Interface

PIN NO.	SYMBOL	DESCRIPTION
1, 17	3.3V	Power positive (3.3V power input)
2, 4	5V	Power positive (5V power input)
3, 5, 7, 8, 10, 11, 12, 13, 15, 16, 18, 24	NC	NC
6, 9, 14, 20, 25	GND	Ground
19	TP_SI	SPI data input of Touch Panel
21	TP_SO	SPI data output of Touch Panel
22	TP_IRQ	Touch Panel interrupt, low level while the Touch Panel detects touching
23	TP_SCK	SPI clock of Touch Panel
26	TP_CS	Touch Panel chip selection, low active

External Dimension

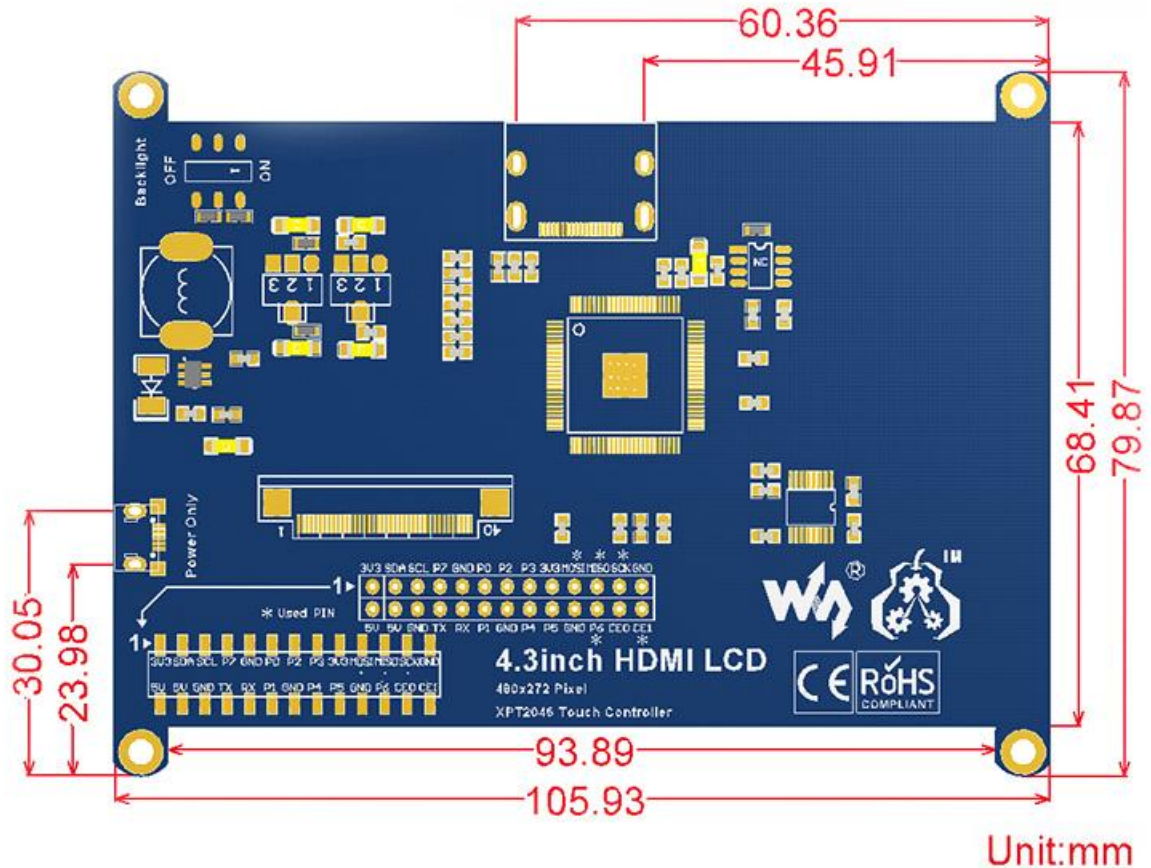

Development Resources

Wiki : www.waveshare.com/wiki/4.3inch_HDMI_LCD

FAQ

Why the LCD doesn't work with my Raspbian?

To use the LCD with the Raspberry Pi official image, driver should be installed first. Please refer to the user manual.

However, for the first testing, you may want to use our provided image directly.

Why the LCD still doesn't work with the Waveshare provided image?

Make sure the hardware connection is correct and connects fine.

Make sure the image in TF card is burnt correctly.

The PWR will keep on and the ACT will keep blinking when the Raspberry Pi starts up successfully, in case both of the two LEDs keep on, it is possible that the image was burnt incorrectly OR the TF card was in bad contact.

Which power supply should I use?

It is strongly recommended to use a stand-alone 5V/2A power adapter, because the PC's USB port might have not enough power to support the Pi and LCD.

For more info, please check the wiki page.