

ITEM	Q'TY	PART NUMBER	PART DESCRIPTION
1	1	H-485C	Quad-Level Sub-Miniature (1.8mm) LED 90° Holder
2	4	1.8XXX	Sub-Miniature (1.8mm) Radial LED, See Page 2

REV.	DESCRIPTION	DATE	APPROVED
A	Engineering Update w/o Changes	03/08/04	M. C.
B	Added P/N Configuration and LED Specs	09/17/09	T. Y.
C	Added H485CBC & H485CBC-Y/G Specs	08/04/16	J. C.

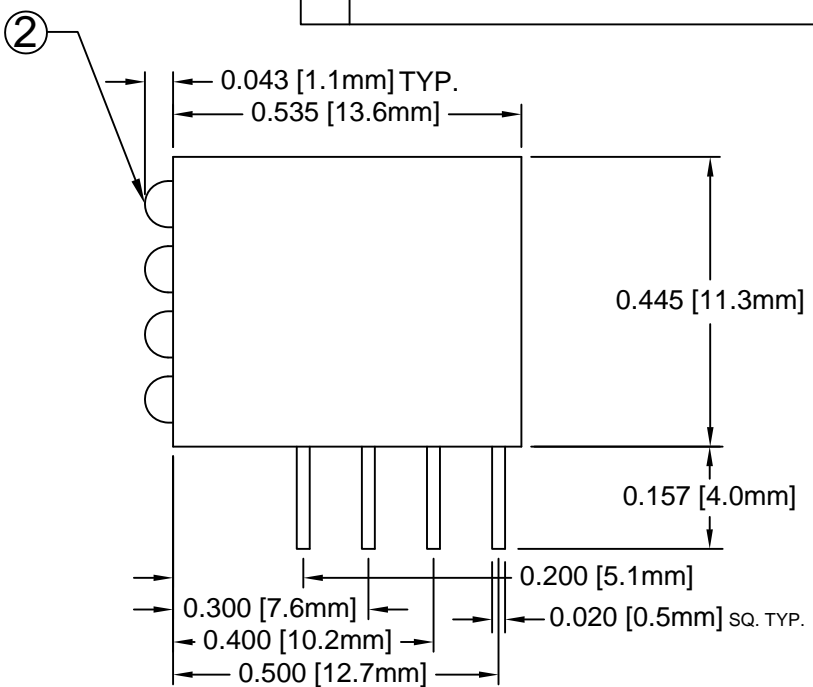

BI-COLOR POLARITY		
LED P/N	(1) CATHODE	(2) CATHODE
1.8BC	GREEN	HE RED
1.8BC-Y/G	GREEN	YELLOW

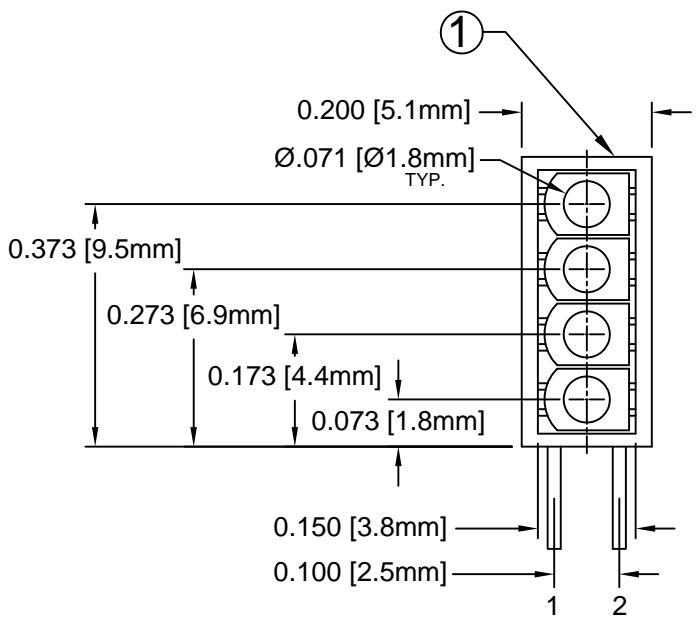
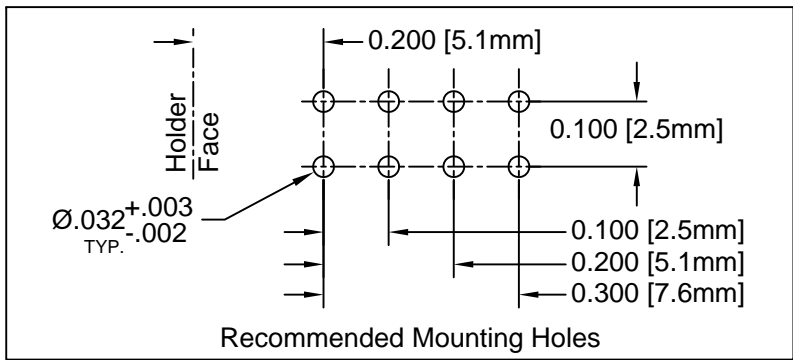
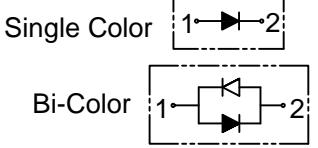

NOTE: P/N CONFIGURATION
H485CXXXXDX

- H-485C Holder Series
- Color of top LED - "X" if blank
- Color of 2nd from top LED - "X" if blank
- Color of 3rd from top LED - "X" if blank
- " " Standard LED
- "L" Low Current LED
- Lens Appearance
- Color of bottom LED - Use "X" if blank

-If LEDs are the same, use e.g. H485CGD

e.g. **H485CRYGXD**

- Series
- Diffused Lens Appearance
- No LED
- Green, 3rd from top
- Yellow, 2nd from top
- Red, top LED
- All Green LEDs

ABSOLUTE MAXIMUM RATINGS (Ta=25° C)

REVERSE VOLTAGE _____ 5V

REVERSE CURRENT _____ 100uA

OPERATING TEMPERATURE RANGE _____ -25° C - 85° C



STORAGE TEMPERATURE _____ -30° C - 100° C

LEAD SOLDERING TEMPERATURE(1/16" FROM BODY) _____ 260° C FOR 5 SECONDS

STANDARD TOLERANCE (UNLESS OTHERWISE SPECIFIED) DECIMALS ANGULAR	 4 THOMAS, IRVINE, CA. 92618 TEL: (949) 951-8808 FAX: (949) 951-3974	
.XXX ± .010		TITLE: SUB-MINIATURE (1.8MM) 90° QUAD-LEVEL LED ASSEMBLY
DESIGNED: T. Yin	DATE: 03/08/04	PART NO: H485CXX
CHECKED: D. Green	DATE: 03/08/04	REVISION: C
CAGE CODE : 32559		SHEET # 1 OF 2
CAD GENERATED DOCUMENT. DO NOT MEASURE DRAWING.		

REV.	DESCRIPTION	DATE	APPROVED
	SEE SHEET #1		

LED Assy. No.	Peak Wave Length λ_p (nm)	Emitted Color	Lens Appearance	Electro-Optical Data				Viewing Angle $2\theta_{1/2}$ (Deg)	LED P/N
				If (mA)	Vf (V)		Iv (mcd)		
				TYP	TYP	MAX	TYP		
STANDARD				Data @ 20mA					
H485CAD	605	AMBER	DIFFUSED	20	2.0	2.8	20	50	1.8AD
H485CBWD	430	BLUE	DIFFUSED	20	4.0	4.5	10	50	1.8BWD
H485CGD	568	GREEN	DIFFUSED	20	2.1	2.8	20	50	1.8GD
H485CHD	625	HE RED	DIFFUSED	20	2.0	2.8	20	50	1.8HD
H485CRD	700	RED	DIFFUSED	20	2.1	2.8	2	50	1.8RD
H485CYD	590	YELLOW	DIFFUSED	20	2.0	2.8	10	50	1.8YD
H485CBC	635	HE RED	WHITE	20	2.0	2.6	4.2	50	1.8BC
	568	GREEN	DIFFUSED	20	2.2	2.6	6.5		
H485CBC-Y/G	590	YELLOW	WHITE	20	2.0	2.8	3.5	50	1.8BC-Y/G
	568	GREEN	DIFFUSED	20	2.1	2.8	4.5		
LOW CURRENT				Data @ 2mA					
H485CADL	605	AMBER	DIFFUSED	2	2.0	2.6	2	50	1.8ADL
H485CBWDL	430	BLUE	DIFFUSED	2	3.8	4.2	1	50	1.8BWDL
H485CGDL	568	GREEN	DIFFUSED	2	2.1	2.6	2	50	1.8GDL
H485CHDL	625	HE RED	DIFFUSED	2	2.0	2.6	2	50	1.8HDL
H485CYDL	590	YELLOW	DIFFUSED	2	2.0	2.6	1	50	1.8YDL

STANDARD TOLERANCE (UNLESS OTHERWISE SPECIFIED) $\pm 10\%$ ALL VALUES ANGULAR		 4 THOMAS, IRVINE, CA. 92618 TEL: (949) 951-8808 FAX: (949) 951-3974	
		 TITLE: SUB-MINIATURE (1.8MM) 90° QUAD-LEVEL LED ASSEMBLY	
DESIGNED: T. Yin	DATE: 03/08/04	PART NO: H485CXX	REVISION: C
CHECKED: D. Green	DATE: 03/08/04	CAGE CODE : 32559	SHEET # 2 OF 2
CAD GENERATED DOCUMENT. DO NOT MEASURE DRAWING.			

Mouser Electronics

Authorized Distributor

Click to View Pricing, Inventory, Delivery & Lifecycle Information:

BIVAR:

[H485CGGGYD](#) [H485CGYHAD](#) [H485CYGGGDL](#) [H485CAAYAD](#) [H485CAGYGD](#) [H485CBWGYHD](#) [H485CBWGYXD](#)
[H485CGAGAD](#) [H485CGGBWGD](#) [H485CGGGHDL](#) [H485CGGHGD](#) [H485CGHGGD](#) [H485CGHHHD](#)
[H485CGRGRD](#) [H485CGXBWGD](#) [H485CGYGGD](#) [H485CGYHGD](#) [H485CGYHYD](#) [H485CGYXXD](#) [H485CHGGGD](#)
[H485CHGGGD-RP](#) [H485CHYGGD](#) [H485CHYGGDL](#) [H485CHYGGD-RP](#) [H485CRD](#) [H485CXXHHD](#) [H485CYGRGD](#)
[H485CYGRYD](#) [H485CYHYHDL](#)